

Features

- H-Bridge Motor Driver, Drives One DC Motor, One Winding of a Stepper Motor, or Other Loads
- Wide 6.5V to 40V Operating Voltage
- 3.6A Peak Current Drive
- PWM Control Interface
- Integrated Current Regulation
- Low-Power Sleep Mode
- VM under voltage Lockout (UVLO)
- Over current Protection (OCP)
- Thermal Shutdown (TSD)
- Automatic Fault Recovery
- Compact package: ESOP8

Applications Marking:

- Printers
- Appliances
- Industrial Equipment
- Vacuum Cleaners Robotics
- Industrial Pumps and Valves
- Other Mechatronics Applications

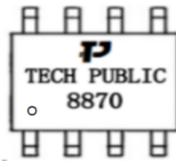

GENERAL DESCRIPTION

The device is a brushed DC motor driver. This device integrates four N-MOSFETs, which can supply up to 3.6A peak current at 40V voltage. The supports PH/EN interface. PWM signal can be implemented on the input interface to adjust motor speed. Customer can adjust PWM current limit or torque in real-time by VREF pin with a controller's DAC output or PWM signal after RC filter. A number of protection features are provided in the device including over-current, short-circuit, under-voltage lockout and thermal shutdown. When the fault condition is removed, the device automatically resumes normal operation.

Pinout (top view)

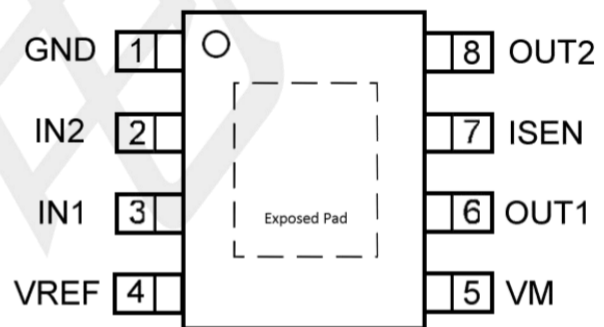

Pin Configurations

Pin Number	Pin Name	Pin Function
1	GND	Logic ground. Connect to board ground
2	IN2	Logic inputs. Controls the H-bridge output. Has 100KΩ internal pulldowns.
3	IN1	Logic inputs. Controls the H-bridge output. Has 100KΩ internal pulldowns.
4	VREF	Analog input. Apply a voltage between 0.3V to 5 V.
5	VM	6.5V to 40V power supply. Connect a 0.1μF bypass capacitor to ground, as well as sufficient bulk capacitance, rated for the VM voltage.
6	OUT1	H-bridge output. Connect directly to the motor or other inductive load.
7	ISEN	High-current ground path. If using current regulation, connect ISEN to a resistor (low-value, high-power-rating) to ground. If not using current regulation, connect ISEN directly to ground.
8	OUT2	H-bridge output. Connect directly to the motor or other inductive load.

BLOCK DIAGRAM

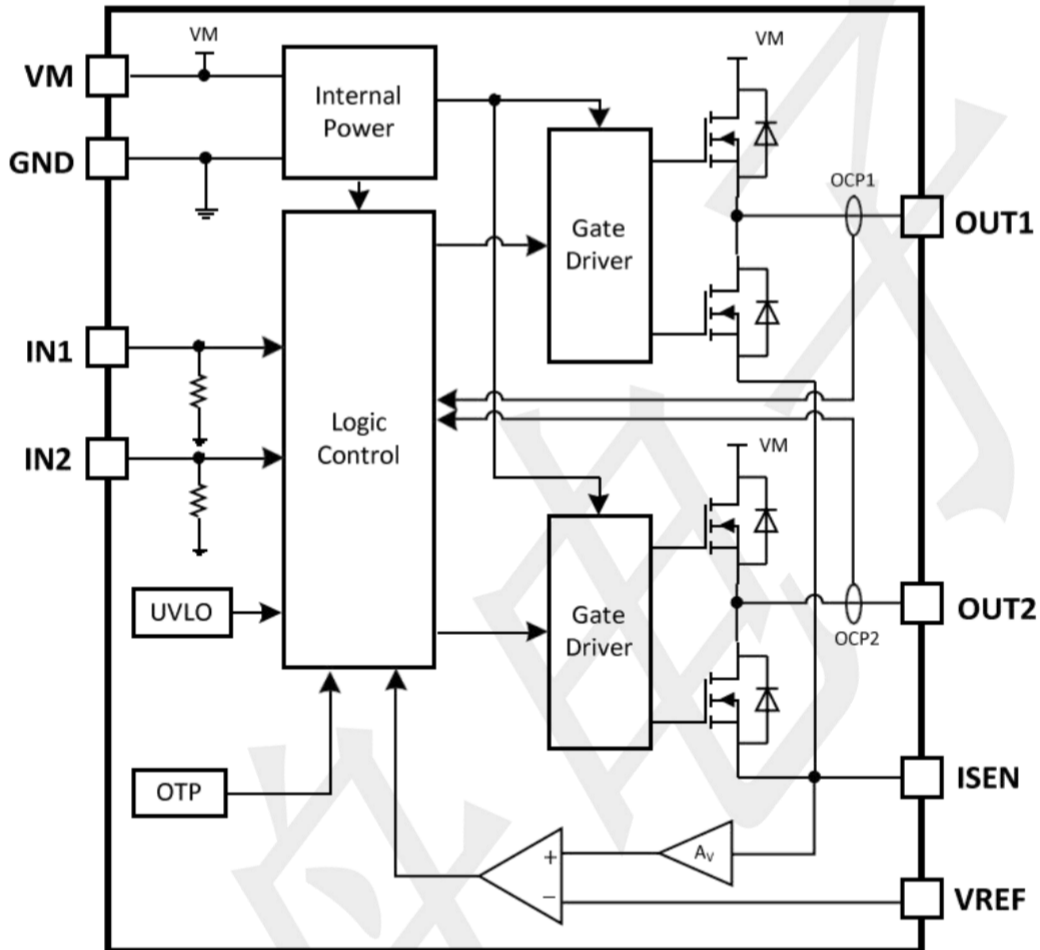

Typical Application Circuit

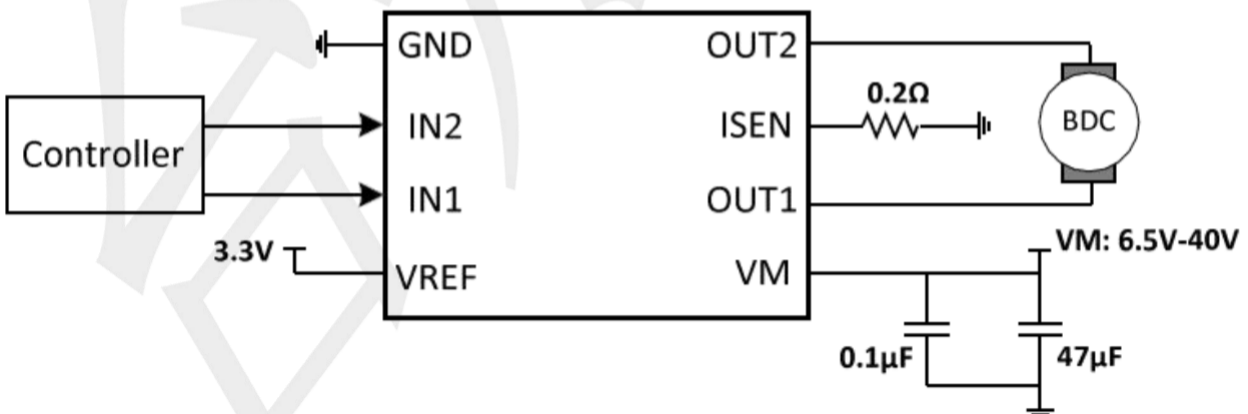

Absolute Maximum Ratings (Note 1)

Parameter	Value		UNIT
	MIN	MAX	
Power supply voltage (VM)	-0.3	45	V
Logic input voltage (IN1, IN2)	-0.3	6.0	V
Reference input pin voltage (VREF)	-0.3	6.0	V
Continuous phase node pin voltage (OUT1, OUT2)	-0.7	VM+0.7	V
Current sense input pin voltage (ISEN)	-0.5	1.0	V
Output current (100% duty cycle)	0	3.5	A
Operating junction temperature (Note 2)	-40	150	°C
Storage temperature	-65	150	°C

ESD RATING

Items	Description	Value	Unit
VESD	Human Body Model for all pins	±2000	V

JEDEC specification JS-001

RECOMMENDED OPERATING CONDITIONS

Items	Description	Min	Max	Unit
VM	Power supply voltage range	6.5	40	V
TJ	Operating Junction Temperature Range	-40	125	°C

ELECTRICAL CHARACTERISTICS

PARAMETER	SYMBOL	TEST CONDITIONS	MIN	TYP	MAX	UNIT
Thermal shutdown temperature	T _{SD}			170		°C
Thermal shutdown hysteresis	T _{HYS}			40		°C

Note 1: Absolute Maximum Ratings are those values beyond which the life of a device may be impaired.

Note 2: TJ is calculated from the ambient temperature TA and power dissipation PD according to the following formula: $T_J = T_A + (PD) \times (250^\circ\text{C}/\text{W})$.

Note 3: 100% production test at +25°C. Specifications over the temperature range are guaranteed by design and characterization.

Note 4: t_{ON} applies when the device initially powers up, and when it exits sleep mode.

Electrical Characteristics (Note 3)

(TA = 25°C, over recommended operating conditions unless otherwise noted.)

PARAMETER	SYMBOL	TEST CONDITIONS	MIN	TYP	MAX	UNIT
POWER SUPPLY (VM)						
VM operating voltage	VM		6.5	--	40	V
VM operating supply current	I _{VM}	VM = 24V	--	2	10	mA
VM sleep current	I _{VM SLEEP}	VM = 24V	--	--	15	μA
Turn-on time (Note 4)	t _{ON}	VM > VUVLO with IN1 or IN2 high	--	45	--	μs
LOGIC-LEVEL INPUTS (IN1, IN2)						
Input logic low voltage	V _{IL}		--	--	0.5	V
Input logic high voltage	V _{IH}		2	--	--	V
Input logic hysteresis	V _{HYS}		--	0.2	--	V
Input logic low current	I _{IL}	VIN = 0V	-1	--	1	μA
Input logic high current	I _{IH}	VIN = 3.3V	--	33	--	μA
Pulldown resistance	R _{PD}	to GND	--	100	--	kΩ
Propagation delay	t _{PD}	Inx H to OUTx H change	--	0.2	--	μs
		Inx L to OUTx L change	--	1.0	--	μs
Time to sleep	t _{sleep}	Inputs low to sleep	--	1.2	2.0	ms
MOTOR DRIVER OUTPUTS (OUT1, OUT2)						
High-side FET on resistance	R _{D S(ON)_High}	VM = 24 V, I = 1A, f _{PWM} = 25 kHz	--	260	300	mΩ
Low-side FET on resistance	R _{D S(ON)_Low}	VM = 24 V, I = 1A, f _{PWM} = 25kHz	--	260	300	mΩ
Output dead time	t _{DEAD}		--	200	--	ns
CURRENT REGULATION						
ISEN gain	A _V	VREF = 2.5V	9.4	10	10.4	V/V
PWM off-time	t _{OFF}		--	30	--	μs
PWM blanking time	t _{BLANK}		--	3.2	--	μs
PROTECTION CIRCUITS						
VM undervoltage lockout	V _{UVLO_fall}	VM falls until UVLO triggers	--	5.8	--	V
	V _{UVLO_rise}	VM rises until operation recovers	--	6.0	--	V
VM undervoltage hysteresis	V _{UV_HYS}	Rising to falling threshold	--	200	--	mV
Overcurrent protection trip level	I _{OCP}		--	4.2	--	A
Overcurrent deglitch time	t _{OCP}		--	2.5	--	μs
Overcurrent retry time	t _{RETRY}		--	4	--	ms

OPERATION

Bridge Control

The output consists of four N-channel MOSFETs that are designed to drive high current. These outputs are controlled by the two logic inputs IN1 and IN2 as listed in Table 1.

Table 1. H-Bridge Control

IN1	IN2	OUT1	OUT2	DESCRIPTION
0	0	High-Z	High-Z	Coast; H-bridge disabled to High-Z (sleep entered after 1.2ms)
0	1	L	H	Reverse (Current OUT2 →OUT1)
1	0	H	L	Forward (Current OUT1 →OUT2)
1	1	L	L	Brake; low-side slow decay

The inputs can be set to static voltages for 100% duty cycle drive, or they can be pulse-width modulated (PWM) for variable motor speed. When using PWM, switching between driving and braking typically works best. For example, to drive a motor forward with 50% of the maximum RPM, IN1 = 1 and IN2 = 0 during the driving period, and IN1 = 1 and IN2 = 1 during the other period. Alternatively, the coast mode (IN1 = 0, IN2 = 0) for fast current decay is also available. The input pins can be powered before VM is applied.

Sleep Mode

When the IN1 and IN2 pins are both low for time tSLEEP (typically 1.2 ms), the device enters a low-power sleep mode, where the outputs remain High-Z and the device uses IVMSLEEP (µA) of current. If the device is powered up while both inputs are low, it immediately enters sleep mode. After the IN1 or IN2 pins are high for at least 5 µs, the device is operational 45 µs (tON) later.

Current Regulation

motor peak current can be limited by the analog reference input VREF and the resistance of external sense resistor on the ISEN pin according to the below equation:

$$I_{TRIP} (A) = \frac{VREF (V)}{A_V \times R_{ISEN}(\Omega)} = \frac{VREF (V)}{10 \times R_{ISEN}(\Omega)}$$

For example, if VREF =2.0V and a RISEN= 0.2Ω, the PWM current regulation mechanism will limits motor current to1.0A mps no matter how much load is applied. When ITRIP is reached, the H-bridge enforces the inductor current into slow decay path by enabling both low-side FETs, and it does this for a fixed off time, TOFF (typically 30µs).

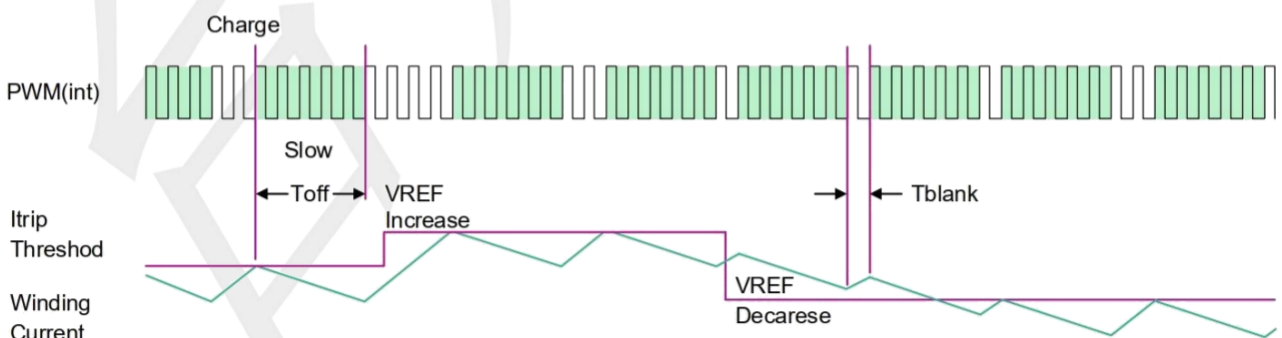

After Toff time passes, the H-bridge output is re-enabled according to the logic states of two inputs, IN1 and IN2, and motor winding current is charging until reaching another ITRIP event, this charge time is heavily depends on the VM voltage, the back-EMF of the motor, and the inductance of the motor.

VM under voltage Lockout (UVLO)

If at any time the voltage on the VM pin falls below the under voltage lockout threshold voltage, all FETs in the H-bridge will be disabled. Operation resumes when VM rises above the UVLO threshold.

Over current Protection (OCP)

If the output current exceeds the OCP threshold, IOCP, for longer than tOCP, all FETs in the H-bridge are disabled. After a duration of tRETRY, the H-bridge is re-enabled according to the state of the INx pins. If the overcurrent fault is still present, the cycle repeats; otherwise normal device operation resumes.

Thermal Shutdown (TSD)

If the die temperature exceeds safe limits, all FETs in the H-bridge are disabled. After the die temperature has fallen to a safe level, operation automatically resumes.

Device Functional Modes

The devices can be used in multiple ways to drive a brushed DC motor.

PWM With Current Regulation

This scheme uses all of the capabilities of the device. The ITRIP current is set above the normal operating current, and high enough to achieve an adequate spin-up time, but low enough to constrain current to a desired level. Motor speed is controlled by the duty cycle of one of the inputs, while the other input is static. Brake or slow decay is typically used during the off-time.

PWM Without Current Regulation

If current regulation is not required, the ISEN pin should be directly connected to the PCB ground plane. The VREF voltage must still be 0.3V to 5 V, and larger voltages provide greater noise margin. This mode provides the highest-possible peak current which is up to 3.6 A for a few hundred milliseconds (depending on PCB characteristics and the ambient temperature). If current exceeds 3.6 A, the device might reach overcurrent protection (OCP) or over temperature shutdown (TSD). If that happens, the device disables and protects itself for about 4ms (tRETRY) and then resumes normal operation.

Static Inputs with Current Regulation

The IN1 and IN2 pins can be set high and low for 100% duty cycle drive, and ITRIP can be used to control the current of the motor, speed, and torque capability.

VM Control

In some systems, varying VM as a means of changing motor speed is desirable.

Package Outline Dimensions (unit: mm)

ESOP-8

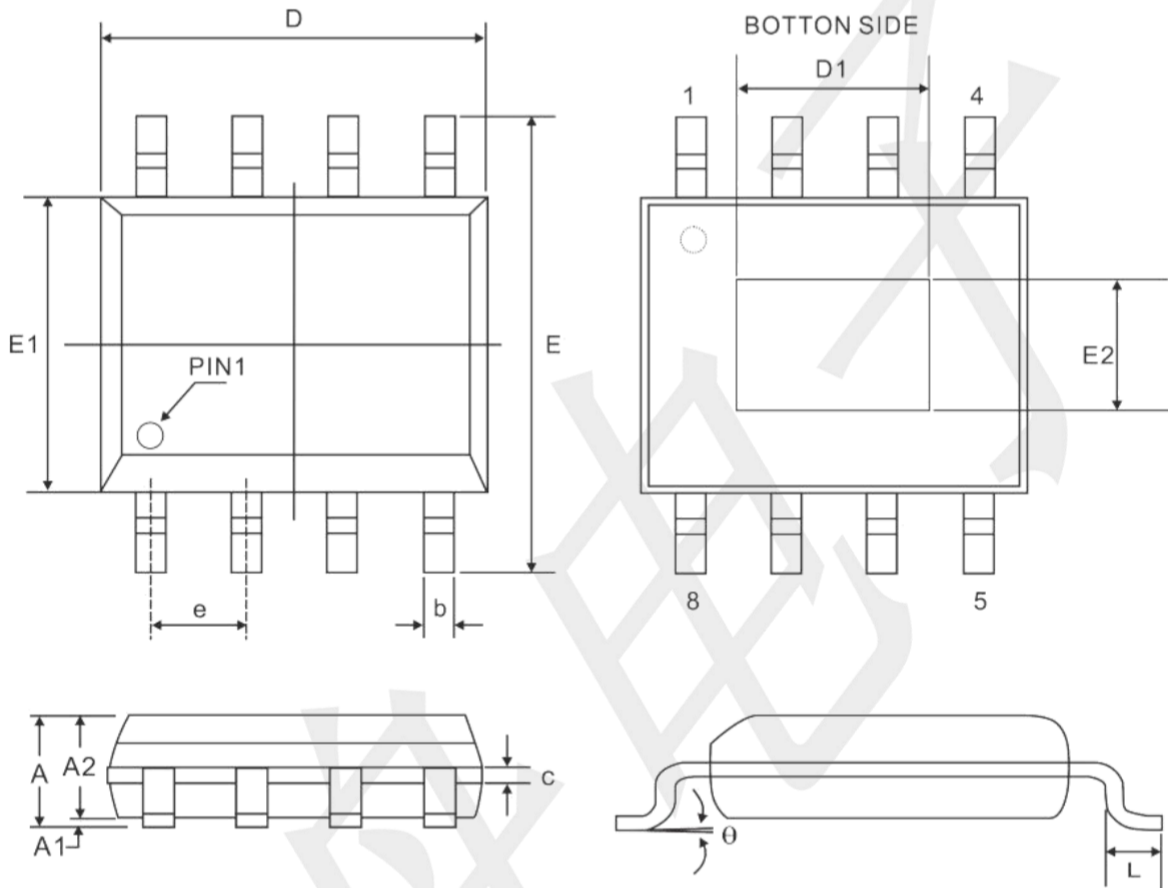

Symbol	Dimensions(mm)		
	Min.	Nom.	Max.
A	-	-	1.70
A1	0.00	-	0.15
A2	1.25	-	-
b	0.31	-	0.51
c	0.10	-	0.25
e	1.27 BSC		
D	4.90 BSC		
D1	2.81	-	3.30
E	6.00 BSC		
E1	3.90 BSC		
E2	2.05	-	2.41
L	0.40	0.60	1.27
θ	0°	-	8°

Notes: Refer to JEDEC MS-012 BA