

SECTION A-A

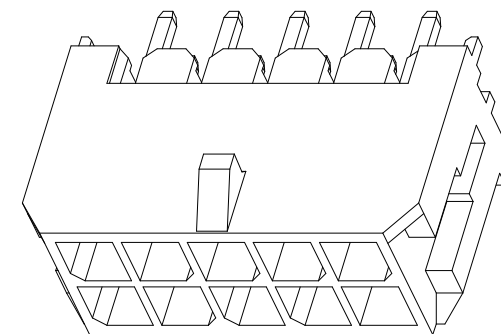

Technical Index:

1. Temperature range: $-25^{\circ}\text{C} \sim +85^{\circ}\text{C}$.
2. Rated voltage: 600V, AC, DC.
3. Rated current: 5.0A AC, DC.
4. Contact resistance: $\leq 20\text{m}\Omega$.
5. Withstanding voltage: 1500V AC/minute.
6. Insulation resistance: $\geq 1000\text{M}\Omega$.

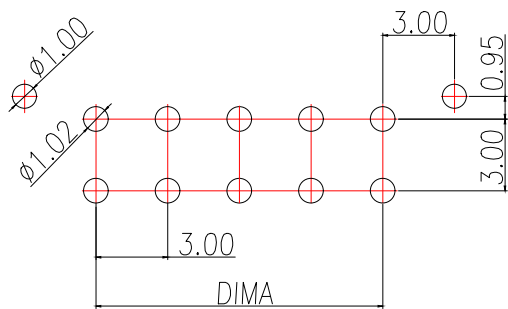
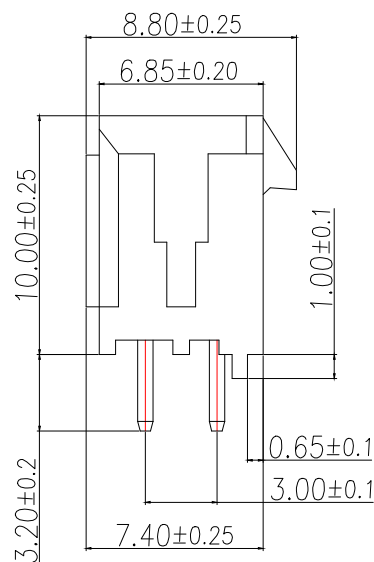
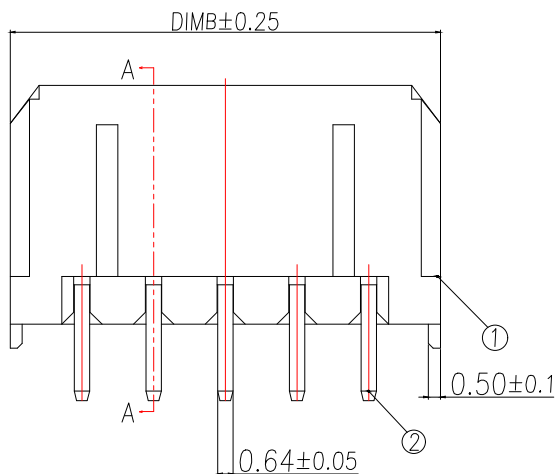

PCB WELDING DRAWING (TOLERANCE: ± 0.05)

型号	CKT	A	B
BX-MX3.0-2-1PZZ	2*1	0.00	6.00
BX-MX3.0-2-2PZZ	2*2	3.00	9.00
BX-MX3.0-2-3PZZ	2*3	6.00	12.00
BX-MX3.0-2-4PZZ	2*4	9.00	15.00
BX-MX3.0-2-5PZZ	2*5	12.00	18.00
BX-MX3.0-2-6PZZ	2*6	15.00	21.00
BX-MX3.0-2-7PZZ	2*7	18.00	24.00
BX-MX3.0-2-8PZZ	2*8	21.00	27.00
BX-MX3.0-2-9PZZ	2*9	24.00	30.00
BX-MX3.0-2-10PZZ	2*10	27.00	33.00
BX-MX3.0-2-11PZZ	2*11	30.00	36.00
BX-MX3.0-2-12PZZ	2*12	33.00	39.00

序号	品名	材质
1	MX3.0双排直针WTB胶芯	PA66 UL94V-0 黑色
2	MX3.0双排直针WTB端子	铜合金/表面镀锡

制图 DRAWN	变更内容 DESCRIPTION	日期 DATE	GENERAL TOLERANCE	
			X.±0.30	X'.:±5°
			.X±0.25	X.X':±1°
			.XX±0.15	

制图 DRAWING	EMMA
审核 CHECK	EVA
核准 APPROVAL	JADE
单位 UNITS	MM
比例 SCALE	1:1

料号 PART NO.	BX-MX3.0-2-NPZZ	版本 REV.	A
品名 TITLE	MX3.0MM WAFER DIP TYPE	页次 SHEET	1/1
客户料号 CUTM.NO.			

JB Bossie (博锡)