

PCB EDGE
RECOMMENDED PCB LAYOUT(TOP VIEW)
(TOLERANCE: ±0.05mm)

Notes:

1. Materials
 - a. Housing: LCP+30% G/F, Black, UL94 V-0;
 - b. Contact: Phosphor Copper (C5191), Gold Plating at mating area, Matte Tin or Au Plating at solder tail, all over Nickel;
 - c. Shell: Phosphor Copper (C5191);
2. Ratings
 - a. Current Rating: 0.3A ;
 - b. Operating Temperature: -40°C ~ 85°C;
3. Electrical Requirement:
 - a. LLCR: Excluding Conductor Resistance 10mΩ Max.(Target design value), Contact: 30mΩ Max. changed (Final), Shell: 50mΩ Max. Changed (Final);
 - b. Dielectric Withstanding Voltage: 150V AC (RMS) for 1 minute (Mated), 250V AC (RMS) for 1 minute (Unmated);
 - c. Insulation Resistance: 10MΩ Min. @ 150V DC (Mated), 100MΩ Min. @ 500V DC (Unmated);
4. Mechanical Performance:
 - a. Insertion force: 44.1N (4.5Kgf) Max.;
 - b. Withdrawal force: 4.9~25N (0.5~2.5Kgf);
 - c. Durability life: 5,000 Cycles;
5. IR Reflow: the peak temperature on board shall be maintained for 10 seconds at 260±5°C.

PIN	Signal Assignment
1	Hot Plug Detect
2	Utility
3	TMDS Data2+
4	TMDS Data2 Shield
5	TMDS Data2-
6	TMDS Data1+
7	TMDS Data1 Shield
8	TMDS Data1-
9	TMDS Data0+
10	TMDS Data0 Shield
11	TMDS Data0-
12	TMDS Clock+
13	TMDS Clock Shield
14	TMDS Clock-
15	CEC
16	DDC/CEC Ground
17	SCL
18	SDA
19	+5V Power

繪圖 DRAWN	規格 DESCRIPTION	日期 DATE	GENERAL TOLERANCE		繪圖 DRAWING	EMMA	料號 PART NO.	BX-HDMI-2-M19P	版次 REV.	A
			X.±0.30	X.*±2°						
			.X±0.25	.X°±0.5°	審核 CHECK	EVA	品名 TITLE	HDMI D TYPE 外殼零件 端子膠片	頁次 SHEET	1/1
			.XX±0.15		核准 APPROVAL	JADE	零件號 CUTM.NO.			
					單位 UNITS	MM	比例 SCALE	1:1		

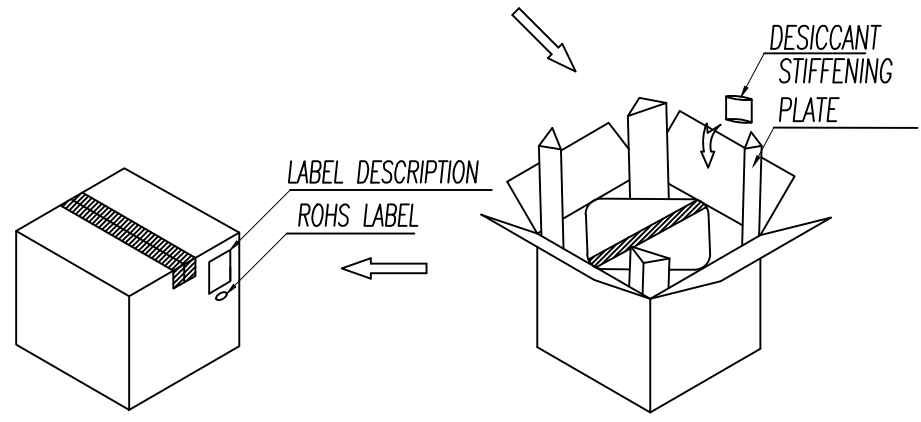
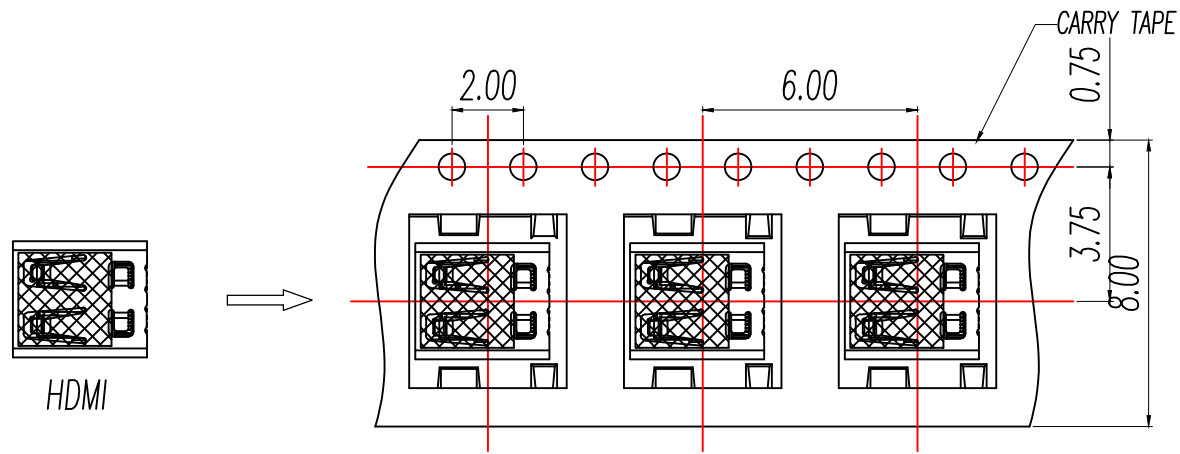
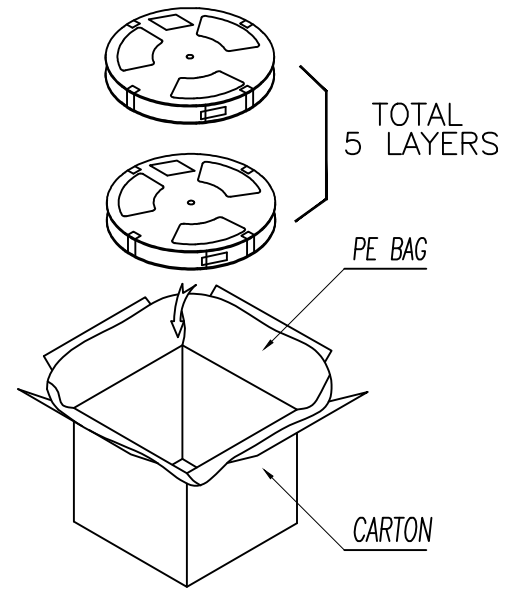
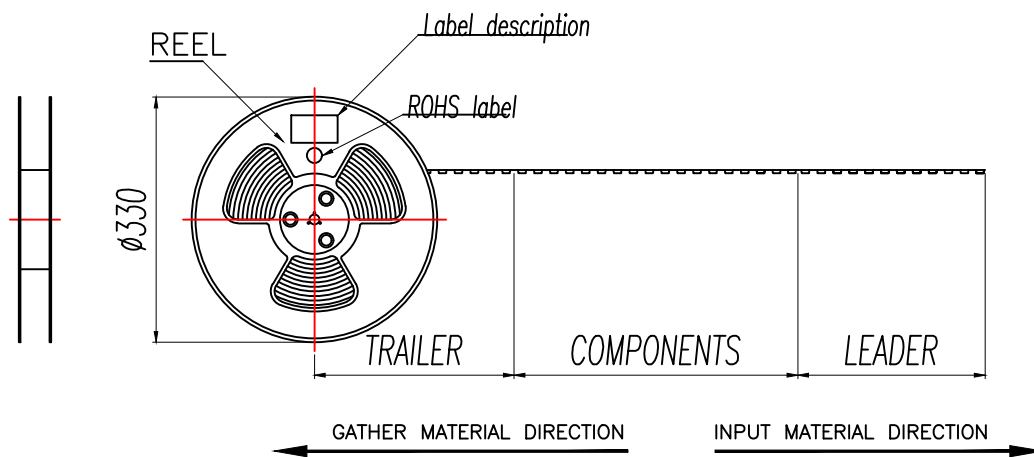

- Notes:
1. The start and end of each reel, based on the actual quantity, reserved 10--15pcs space;
 2. Peel off force of top tape: 10g~130g, peel deg.:165~175~; peel speed: 250~300mm/min;
 3. Carton size: 350*350*155mm.
 4. QTY: 1000pcs/reel, 5reel/carton, total 6000pcs/carton;

繪圖 DRAWN	規格 DESCRIPTION	日期 DATE	GENERAL TOLERANCE		繪圖 DRAWING	EMMA	料號 PART NO.	BX-HDMI-2-M19P	版次 REV.	A
			X.±0.30	X.±2°						
				核准 APPROVAL	JADE	料號 CUTM.NO.		圖標	圖標	
			.X±0.25							.X±0.5°
			.XX±0.15							