

3	焊片 Fitting Nail	黄铜	2	电镀(锡):整个表面镀底镍 30u"MIN,再镀锡80u"MIN
2	端子 Contact	黄铜	N*1	电镀(锡):整个表面镀底镍 30u"MIN,再镀锡80u"MIN
1	基座 Wafer	LCP (UL94V-0)	1	米色
序号	名称	材料	数量	备注

SUGGESTED PCB LAYOUT  
(COMPONENT SIDE)

Part No	Pin	A	B	C
BX-VH3.96-2PLT	2	3.96	11.88	8.60
BX-VH3.96-3PLT	3	7.92	15.84	12.56
BX-VH3.96-4PLT	4	11.88	19.80	16.52
BX-VH3.96-5PLT	5	15.84	23.76	20.48
BX-VH3.96-6PLT	6	19.80	27.72	24.44
BX-VH3.96-7PLT	7	23.76	31.68	28.40
BX-VH3.96-8PLT	8	27.72	35.64	32.36
BX-VH3.96-9PLT	9	31.68	39.60	36.32
BX-VH3.96-10PLT	10	35.64	43.56	40.28

技术要求:

1. 塑料材料:LCP(UL-94V-0)
2. 接触件:黄铜镀锡
3. 接触电阻: $\leq 30m\Omega$
4. 绝缘电阻: $\geq 1000M\Omega$
5. 额定电压:250V AC DC
6. 额定电流:7.0A AC DC
7. 耐压:能承受1000V AC/Minute
8. 工作温度: $-25^{\circ}\sim+85^{\circ}$
9. 可焊性试验:浸锡面积 $\geq 95\%$ 温度260, 时间 $2.5\pm 0.5$ 秒
10. 铅和镉等六大有害物质含量要符合环保要求。

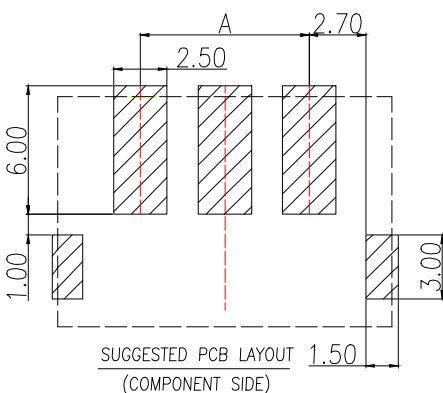

制图 DRAWN	变更内容 DESCRIPTION	日期 DATE	GENERAL TOLERANCE		制图 DRAWING	EMMA	料号 PART NO.	BX-VH3.96-NPLT	版本 REV.	A
			X.±0.25	X'.:±3'						
			.X±0.12		审核 CHECK	EVA	品名 TITLE	压接式(条形)连接器	页次 SHEET	1/1
			.XX±0.05		核准 APPROVAL	JADE	客户料号 CUTM.NO.			
					单位 UNITS	MM	比例 SCALE	1:1		