

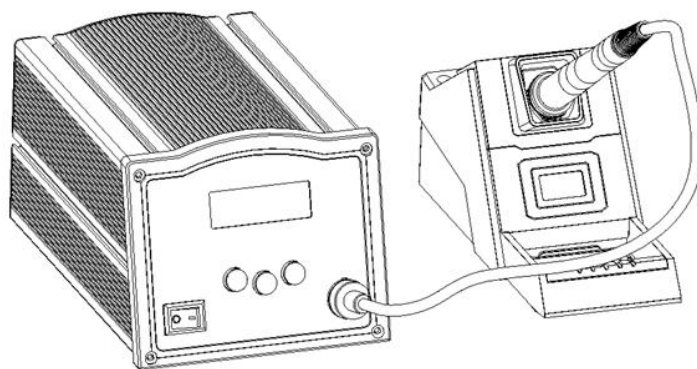

QUICK 203H+

Lead Free Soldering Station

Instruction Manual



**Thank you for purchasing our products. Please keep the instruction properly for future reference.**

# Contents

1. Safety Instruction.....	1
2. Product Overview.....	2
3. Product Features.....	2
4. Product Specifications.....	3
5. Function Descriptions.....	3
5.1 Dimensions.....	3
5.2 Part Descriptions.....	4
5.3 Button Descriptions.....	4
5.4 Main Menu.....	5
6. Connection.....	5
7. Temperature Setup.....	5
7.1 Select & Switch Temperature.....	5
7.2 Set Temperature and Save.....	6
8. Tone Setup.....	6
9. Sleeping and Resume.....	6
9.1 Sleeping.....	6
9.2 Resume.....	7
10. Password Setup.....	7

11. Parameter Setup.....	8
12. Sleeping Time Setup.....	9
13. Standby Time Setup.....	10
14. New Password Setup.....	10
15. Temperature Calibration.....	11
16. Tip Maintenance.....	12
17. Tip Options.....	13
18. Soldering Station Heater Replacement.....	13
18.1 Steps of removing the Heater.....	14
18.2 Steps of replacing the Heater.....	14
19. Troubleshooting.....	15
20. Tips.....	15

# 1. Safety Instruction



## CAUTION

- During the installation and use of the product, observe the electrical safety regulation of location.
- Please power off the product during disassembly.
- If the product is not working properly, please contact the supplier or manufacture, do not disassemble or modify without notice.



## WARNING

- Products should be used away from magnetic field.
- Do not place the product where the surface is vibrated or subject to shocks.
- Do not install the product where it maybe wet.
- Do not use the product near flammable materials.
- When the station is turned on and the soldering tip is in a high temperature state, do not touch it with your hands to avoid burns.
- Turn off the station when resting or after completion.
- Do not knock the tip on the workbench to remove the oxides.
- Power off the station to prolong heating element lifetime when not using in a long time.
- Unplug the power cable when the station is not use for a long time.

## 2. Product Overview

The soldering station adopts LCD liquid crystal display and mechanical button, which is more comfortable to use.

## 3. Product Features

- Megaxonal high-frequency eddy current heating and sensor front-facing design.
- Features a dual-temperature display with a backlit LCD.
- CNC controls the heating and cooling process quickly, allowing for lead-free welding.
- Built-in intelligent temperature compensation system, which ensures precise and stable temperature.
- Digital temperature calibration, heating core plug and plug design, easier maintenance.
- Plug design to allow for more reliable grounding.

## 4. Product Specifications

Product model	203H+
Display	LCD
Power	90W
Input voltage	220VAC
Temp. range	100°C ~ 500°C
Temperature Stability	±2°C (no load)
Operation ambient	0~40°C
Tip to ground potential	<2mV
Tip to ground resistance	<2Ω
Dimension(L*W*H)	171.5*130.6*104.8 mm
Weight	about 3.1 Kg

## 5. Function Descriptions

### 5.1 Dimensions

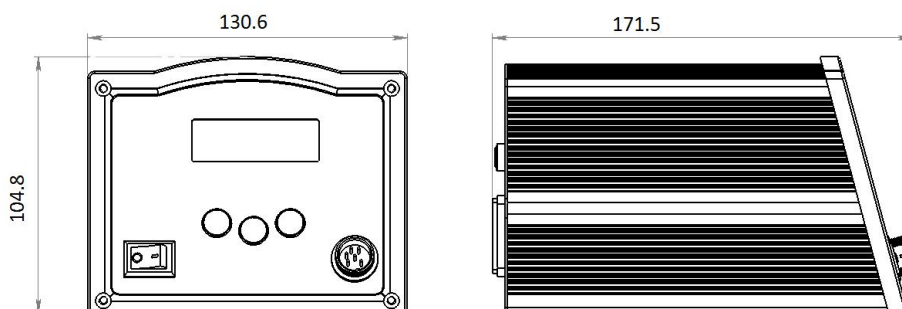

Unit: mm

## 5.2 Part Descriptions

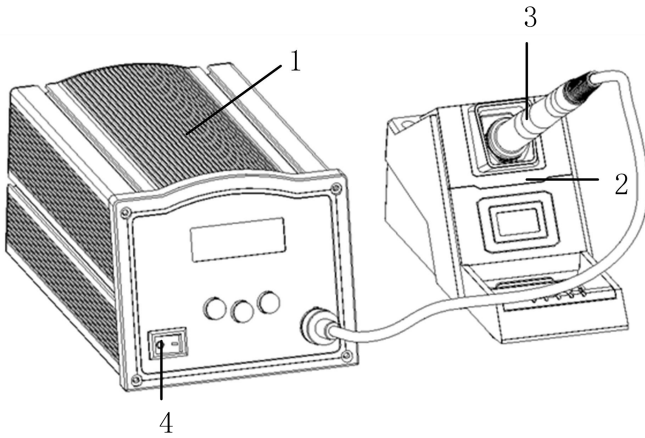



No.	Part Name
1	Soldering Station
2	Iron Stand
3	Soldering Iron
4	Power Switch

## 5.3 Button Descriptions

No.	Button	Descriptions
1	▲	In the Main menu, Press button once to increase 1°C, press and hold it to continuously increase.
2	▼	In the Main menu, Press button once to decrease 1°C, press and hold it to continuously decrease.
3	*	In the Main menu, Press button to Select & switch temperature. three favorite temperatures can be set here. In the Main menu, Press ▲ or ▼ button to Change the temperature, and then, Long press the * key to save
4	▲ and ▼	In the Main menu, Press and hold it at the same time to turn on or off the sound.
5	* and ▲ and ▼	In the Main menu, Press and hold it at the same time to temperature calibration mode.

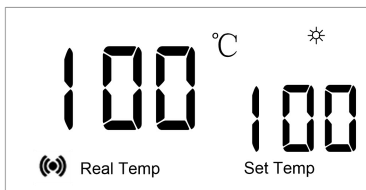
## 5.4 Main Menu



Icon	Descriptions
	Heating State
	Turn on: Shows the buzzer is open Turn off: Shows the buzzer is close
Real Temp	/
Set Temp	/

## 6. Connection

- 1) Connect the 6-pin plug into station, and make sure the pin in the plug must match the groove in the connection socket. Place the soldering iron handle in the iron holder.
- 2) Insert the power plug into grounded power socket.
- 3) Turn on the power switch.

## 7. Temperature Setup

### 7.1 Select & Switch Temperature

- 1) In the Main menu, three temperatures can be set here. In the window, it displays (Set Temp) and (Real Temp).
- 2) Select & switch temperature: In the Main menu, press the “\*” button and then loosen, the window will display one temperature, and this is the favorite temperature setting state. Press “\*” again, it will display another favorite temperature.
- 3) In password locking state, temperature cannot be set but the three favorite temperatures can be selected freely.

## 7.2 Set Temperature and Save

- 1) If the three temperatures need to be changed, click the “▲” or “▼” button to set.
- 2) After setting, press the “\*” button until the window displays “□.F”, it means the temperature is set and saved successfully. Otherwise, the temperature is not saved, After the system is switched over again or restarted, the temperature is still displayed as before.

## 8. Tone Setup

In the Main menu, press the “▲” and “▼” buttons simultaneously and keep about 2s. The sound will be turned on if the window displays “(●)”, and will be off if the window displays “OFF”.

NOTE: 1) When the sound is turned on, it will sound when click the buttons.

2) When the sound is turned on, the difference in temperature of “Real Temp” and “Set Temp” is bigger than  $\pm 20^{\circ}\text{C}$ , it will alarm.

3) If the sound is turned off, it will not have alarm and sound.

## 9. Sleeping and Resume

### 9.1 Sleeping

- 1) The window displays “---” and “sleep” after into the sleeping state.
- 2) The handle is placed on the soldering iron rack. If it does not wake up within the set

time, it will enter sleeping.

## 9.2 Resume

Resume the soldering state from sleeping state: take up the soldering iron handle from the soldering holder.

# 10. Password Setup

The initial password is "000", and in this state, you can set the temperature. If you need to limit the temperature adjustment, you must change the password.

### Enter the password setting state

- 1) Turn off the power switch. Press and hold the “▲” and “▼” buttons simultaneously, then turn on the power switch.
- 2) Continue holding down the “▲” and “▼” button until the display shows  .
- 3) When the display shows ,the station is in parameter input mode.

### Enter the old password

- 1) Press the “\*” button,, the window will display “---” , the 100’ s digit will flash, initial password can be inputted.
- 2) Input password: Click the “▲” or “▼” button to input the 100’ s digit, and then click the “\*” button when displaying the selected value of 100’ s digit. After that it comes into 10’ s digit input. The inputting methods of the 10’ s digit and 1’ s digit are same

with the 100' s digit.

- 3) If the inputting password is wrong for the first time, it comes into the password-inputting interface again and the window displays “---” . Input the password again as the step 2.
- 4) If the inputting passwords both are wrong, the window displays “Err” . It cannot come into the parameter setting and return to the work state directly.
- 5) If the inputting password is right, it comes into the parameter setting. Firstly, the window displays “-1-” , working mode setting interface.

## 11. Parameter Setup

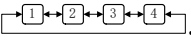
- 1) There are 4 parameter menus and it can switch among them by clicking “▲” or “▼” button. The switching order is as: .
- 2) This menu has “Exit” function. press “▲” or “▼” button to select the menu “-1-”. After that if click “\*” button, it will exit from the parameter setting and comes into the work mode.
- 3) This menu has “Sleeping Time Setting” function. press “▲” or “▼” button to select the menu “-2-”. After that, if click “\*” button, it comes into the sleeping time setting interface .
- 4) This menu has “Standby time setting” function. press “▲” or “▼” button to select the menu “-3-”. After that, if click “\*” button, it comes into the work mode setting interface .

5) This menu has “New Password Setting” function. press“▲” or “▼” button to select the menu “-4-”. After that, if click “\*” button, it comes into the password setting interface .

## 12. Sleeping Time Setup

1) In the parameter menu selecting interface, click “▲” or “▼” button to select the menu “-2-”, and then press “\*” button into the sleeping time setting interface. The default sleeping time is 20minutes, so the screen displays “20”.

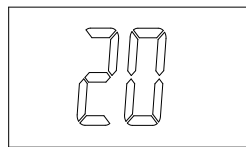

Sleeping time setting interface

2) In the sleeping time setting interface, click “▲” or “▼” button to adjust the sleeping time. The sleeping time setting range is “01~99” or “--” (unit: minute) .

**01~99:** means when putting the soldering iron on the soldering holder, it comes into the sleeping state after the setting time.

--: means the soldering iron will not come into the sleeping state.

3) After finishing setting the sleeping time, click “\*” key to save and then return to the parameter menu selecting interface.

## 13. Standby Time Setup

1) In the parameter menu selecting interface, press “▲” or “▼” button to select the menu “-3-”, and then press “\*” button into Standby time setting interface. The factory default standby time is 60 minutes. ( 60 is displayed in the window )

2) In the Standby time setting interface, press “▲” or “▼” button to adjust shutdown time. Standby time: 01 to 99 / -- (unit: minute)

01~99: Standby time, from the start of hibernation time.

-- : no standby

OFF: standby

3) After finishing setting the standby mode, press “\*” key to save and then return to the parameter menu selecting interface.

## 14. New Password Setup

1) In the parameter menu selecting interface, click “▲” or “▼” button to select the menu “-4-”, and then click “\*” button into the password setting interface.

2) On the password setting interface, the window displays "--" and the hundred digit blinks. Then click the "▲" or "▼" button and select the hundreds digit. After selecting, click the "\*" key to enter the tens digit selection, the tens and ones digit selection method is the same as the hundreds digit. Select the ones digit and click "\*" to enter the second password. The method of setting the password for the second time is the same as the method of setting the password for the first time. After entering the password for the

second time, click \*.

3) If the inputting passwords are not same with each other, it will return to the working state directly, which means the password setting is not successfully.

4) If the inputting passwords are same with each other, the windows displays “**PF**” , and then return to the parameter menu selecting interface, which means the password setting is successfully.

## 15. Temperature Calibration

The temperature should be recalibrated every time if the handle, heating element or soldering tip is replaced.

1) Set the temperature 300°C. When the temperature is stable, measure the tip's temperature with a thermometer and write down the value.

2) Press the “▲” & “▼” buttons simultaneously, press the “\*” button until the window displays “CAL” to enter the calibrating temperature mode.

3) Press the “▲” or “▼” key for numerical selection, input the reading value of the temperature tester, input, press the “\*” key to save, the iron temperature calibration is completed.

4) If the temperature calibration is successful, the window will display “”, and then return to the working interface. If the temperature calibration fails, Err is displayed and the working screen is displayed.

Repeat the above steps if there's any difference between the thermometer and soldering station.

Note: It is recommended to use QUICK 191/192 series temperature tester to measure tip temperature.

## 16. Tip Maintenance

- 1) When a new tip is used for the first time, set 250 to 280°C to protect the tip with solder.
- 2) Select the tip size according to the size of the solder joint.
- 3) To prevent tip oxidation, a fresh layer of solder should be plated before putting back into the soldering iron holder.
- 4) There should not be too much water in the cleaning sponge to get a good cleaning effect on the tip and to avoid rapid temperature drop of the tip. Using a dry & cleaning sponge will damage the tip and cause no tinning.
- 5) After the tip is improperly oxidized by use, do not clean the surface plating by grinding. Please use metal wire or resurrection paste to clean the tip at low temperature (250~280°C) .
- 6) Do not apply heavy force to the tip when soldering and avoid using tin to the same place.
- 7) Use low-temperature soldering as much as possible. Generally, the soldering temperature is controlled at 320~380°C. If you need to set a high temperature to solder, please analyze whether the soldering station and tip are matched, and then perform soldering.

## 17. Tip Options

A large selection of soldering tips allows a very wide range of applications.

- 1) A suitable soldering tip is essential for efficient process and lifetime.
- 2) Soldering tip dimension is relevant to heating capacity. The larger dimension, the higher heating capacity. If the heating capacity is reasonable the soldering process can be set temperature as per application but as low as possible.
- 3) Choose the soldering tip that fully contacts the solder joints. The movement of tip should not meet the other components during process.



## 18. Soldering Station Heater Replacement

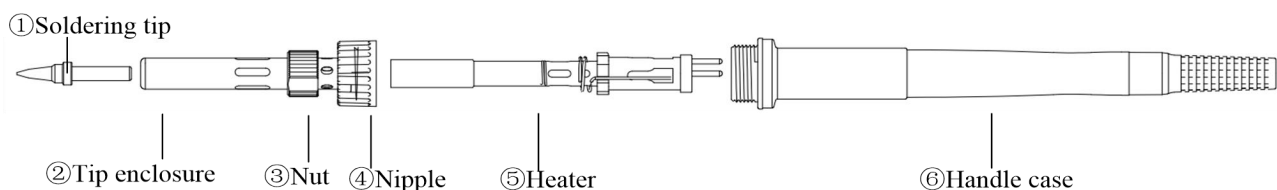

## 18.1 Steps of removing Heater

- 1) Screw down the ② Tip enclosure and ③ Nut;
- 2) Pull out the ① Soldering tip;
- 3) Screw down ④ Nipple;
- 4) Pull out the ⑤ Heater .

⚠ Note: All operating steps are performed with the power disconnected and the handle cooled.

## 18.2 Steps of replacing the Heater

- 1) Install ⑤ Heater into ⑧ Handle case;
- 2) Screw on ④ Nipple and install ① Soldering tip;
- 3) Put ② Tip enclosure and ③ Nut on ④ Nipple and tighten them;
- 4) After replacing the heater, the following measurements are recommended:

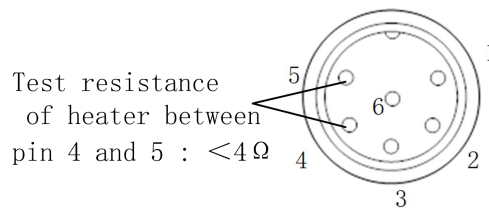

- 5) Calibrate the temperature, refer to Soldering temperature calibration.

# 19. Troubleshooting

No.	Error	Fault Descriptions
1	S-E	The sensor is error If the sensor or other parts of the sensor circuit fails, the "S-E" mark is displayed and the current to the soldering iron is cut off.
2	H-E	The heater is error If the soldering station cannot deliver power to the soldering iron heater, the window displays "H-E", indicating that the heater is damaged.

# 20. Tips

