

## Features

We declare that the material of product are Halogen Free and compliance with RoHS requirements.

402

SOT-363

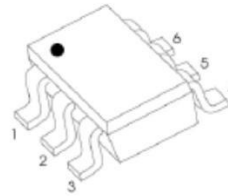

Equivalent Circuit

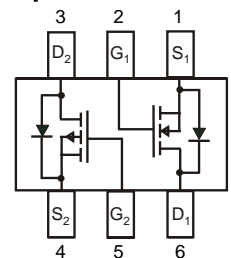

## MAXIMUM RATINGS AND ELECTRICAL CHARACTERISTICS

### MAXIMUM RATINGS TR1 ( $T_a=25^\circ\text{C}$ unless otherwise noted)

Rating	Symbol	Value	Unit
Drain-to-Source Voltage	$V_{DSS}$	50	V <sub>dc</sub>
Gate-to-Source Voltage – Continuous	$V_{GS}$	$\pm 20$	V <sub>dc</sub>
Drain Current			mA
– Continuous @ $T_A = 25^\circ\text{C}$	$I_D$	130	
– Pulsed Drain Current ( $t_p \leq 10 \mu\text{s}$ )	$I_{DM}$	520	
Total Power Dissipation @ $T_A = 25^\circ\text{C}$	$P_D$	380	mW
Operating and Storage Temperature Range	$T_J, T_{stg}$	– 55 to 150	$^\circ\text{C}$
Thermal Resistance – Junction-to-Ambient	$R_{\theta JA}$	328	$^\circ\text{C}/\text{W}$
Maximum Lead Temperature for Soldering Purposes, for 10 seconds	$T_L$	260	$^\circ\text{C}$

## Electrical Characteristics ( $T_a=25^\circ\text{C}$ unless otherwise noted)

### N-Channel

Characteristic	Symbol	Min	Typ	Max	Unit
<b>OFF CHARACTERISTICS</b>					
Drain-to-Source Breakdown Voltage ( $V_{GS} = 0 \text{ Vdc}$ , $I_D = 250 \mu\text{Adc}$ )	$V_{(BR)DSS}$	50	–	–	Vdc
Zero Gate Voltage Drain Current ( $V_{DS} = 25 \text{ Vdc}$ , $V_{GS} = 0 \text{ Vdc}$ ) ( $V_{DS} = 50 \text{ Vdc}$ , $V_{GS} = 0 \text{ Vdc}$ )	$I_{DSS}$	– –	– –	0.1 0.5	$\mu\text{Adc}$
Gate-Source Leakage Current ( $V_{GS} = \pm 20 \text{ Vdc}$ , $V_{DS} = 0 \text{ Vdc}$ )	$I_{GSS}$	–	–	$\pm 0.1$	$\mu\text{Adc}$
<b>ON CHARACTERISTICS</b> (Note 1.)					
Gate-Source Threshold Voltage ( $V_{DS} = V_{GS}$ , $I_D = 1.0 \text{ mAdc}$ )	$V_{GS(th)}$	0.8	–	2.0	Vdc
Static Drain-to-Source On-Resistance ( $V_{GS} = 2.75 \text{ Vdc}$ , $I_D < 200 \text{ mAdc}$ , $T_A = -40^\circ\text{C}$ to $+85^\circ\text{C}$ ) ( $V_{GS} = 5.0 \text{ Vdc}$ , $I_D = 200 \text{ mAdc}$ )	$r_{DS(on)}$	– –	5.6 –	10 3.5	Ohms

### DYNAMIC CHARACTERISTICS

Input Capacitance	( $V_{DS} = 25 \text{ Vdc}$ , $V_{GS} = 0$ , $f = 1 \text{ MHz}$ )	$C_{iss}$	–	42	–	pF
Output Capacitance	( $V_{DS} = 25 \text{ Vdc}$ , $V_{GS} = 0$ , $f = 1 \text{ MHz}$ )	$C_{oss}$	–	15	–	
Transfer Capacitance	( $V_{DG} = 25 \text{ Vdc}$ , $V_{GS} = 0$ , $f = 1 \text{ MHz}$ )	$C_{rss}$	–	3	–	

### SWITCHING CHARACTERISTICS

 (Note 2.)

Turn-On Delay Time	( $V_{DD} = 30 \text{ Vdc}$ , $I_D = 0.2 \text{ Adc}$ , )	$t_{d(on)}$	–	5	–	ns
Turn-Off Delay Time		$t_{d(off)}$	–	7	–	

1. Pulse Test: Pulse Width  $\leq 300 \mu\text{s}$ , Duty Cycle  $\leq 2\%$ .
2. Switching characteristics are independent of operating junction temperature.

### P-Channel

#### OFF CHARACTERISTICS

Drain-to-Source Breakdown Voltage ( $V_{GS} = 0 \text{ Vdc}$ , $I_D = -250 \mu\text{Adc}$ )	$V_{(BR)DSS}$	-50	–	–	Vdc
Zero Gate Voltage Drain Current ( $V_{DS} = -25 \text{ Vdc}$ , $V_{GS} = 0 \text{ Vdc}$ ) ( $V_{DS} = -50 \text{ Vdc}$ , $V_{GS} = 0 \text{ Vdc}$ ) ( $V_{DS} = -50 \text{ Vdc}$ , $V_{GS} = 0 \text{ Vdc}$ , $T_J = 125^\circ\text{C}$ )	$I_{DSS}$	– – –	– – –	-0.1 -15 -60	$\mu\text{Adc}$
Gate-Body Leakage Current ( $V_{GS} = \pm 20 \text{ Vdc}$ , $V_{DS} = 0 \text{ Vdc}$ )	$I_{GSS}$	–	–	$\pm 100$	nAdc

#### ON CHARACTERISTICS

 (Note 1.)

Gate-Source Threshold Voltage ( $V_{DS} = V_{GS}$ , $I_D = -250 \mu\text{Adc}$ )	$V_{GS(th)}$	-0.8	–	-2.0	Vdc
Static Drain-to-Source On-Resistance ( $V_{GS} = -5.0 \text{ Vdc}$ , $I_D = -100 \text{ mAdc}$ )	$r_{DS(on)}$	–	5.0	10	Ohms

#### DYNAMIC CHARACTERISTICS

Input Capacitance	( $V_{DS} = -5.0 \text{ Vdc}$ )	$C_{iss}$	–	30	–	pF
Output Capacitance	( $V_{DS} = -5.0 \text{ Vdc}$ )	$C_{oss}$	–	10	–	
Transfer Capacitance	( $V_{DG} = -5.0 \text{ Vdc}$ )	$C_{rss}$	–	5.0	–	

#### SWITCHING CHARACTERISTICS

 (Note 2.)

Turn-On Delay Time	( $V_{DD} = -15 \text{ Vdc}$ , $I_D = -2.5 \text{ Adc}$ , $R_L = 50 \Omega$ )	$t_{d(on)}$	–	13	–	ns
Rise Time		$t_r$	–	6	–	
Turn-Off Delay Time		$t_{d(off)}$	–	16	–	
Fall Time		$t_f$	–	3	–	
Gate Charge		$Q_T$	–	6000	–	pC

1. Pulse Test: Pulse Width  $\leq 300 \mu\text{s}$ , Duty Cycle  $\leq 2\%$ .
2. Switching characteristics are independent of operating junction temperature.

RATING AND CHARACTERISTIC CURVES

**N-Channel**

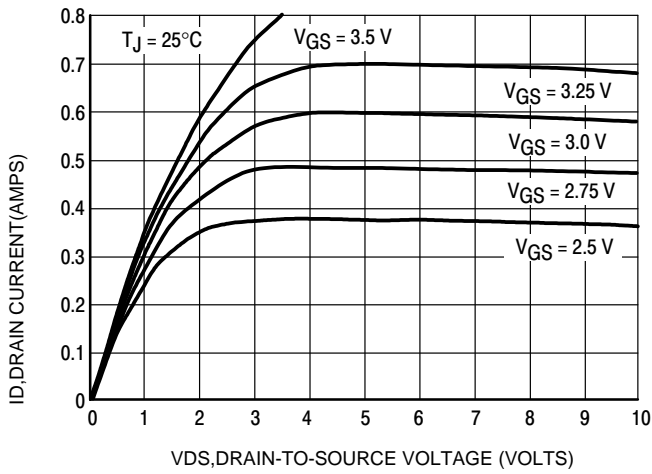

Figure 1. On-Region Characteristics

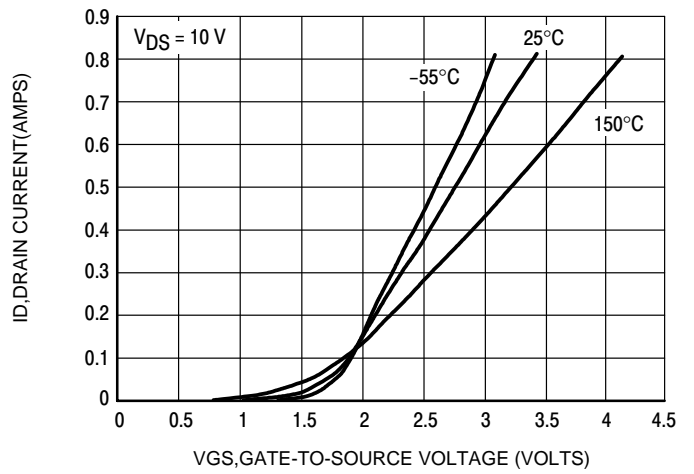

Figure 2. Transfer Characteristics

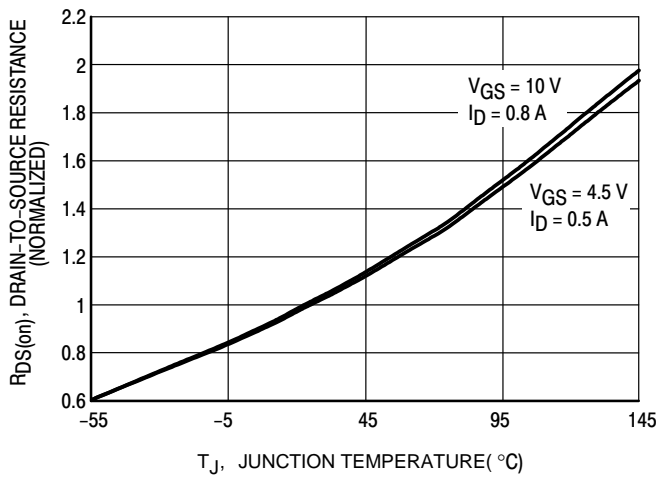

Figure 3. On-Resistance Variation with Temperature

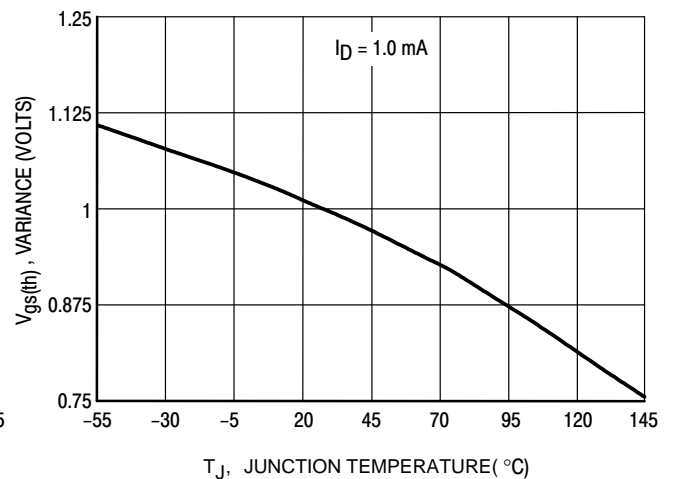

Figure 4. Threshold Voltage Variation with Temperature

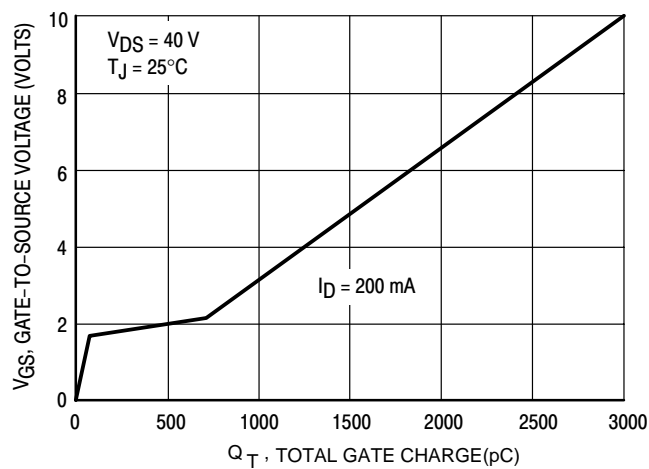
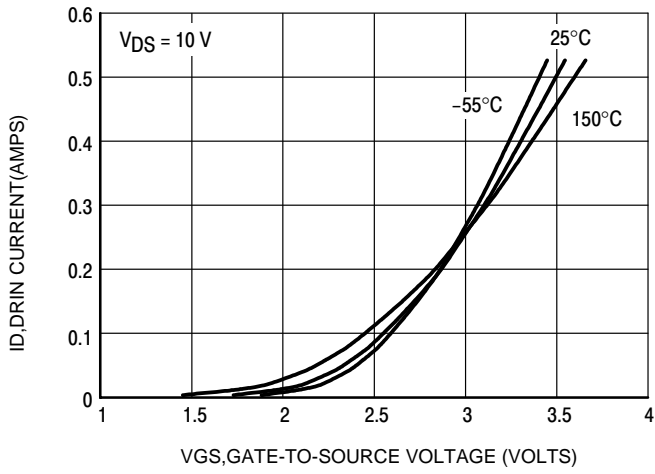

Figure 5. Gate Charge

**RATING AND CHARACTERISTIC CURVES**

**P-Channel**



**Figure 1. Transfer Characteristics**

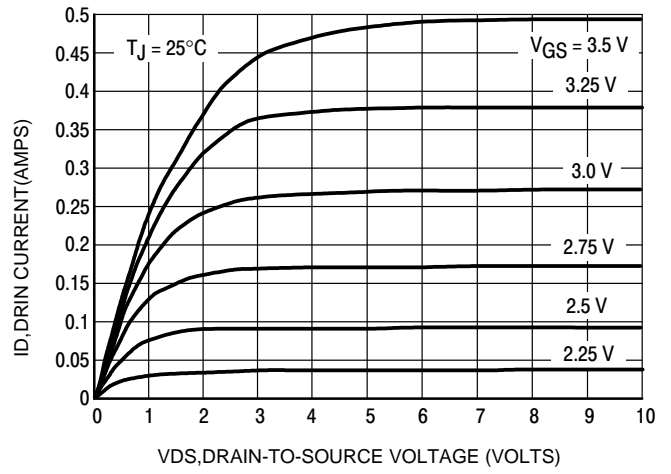

**Figure 2. On-Region Characteristics**

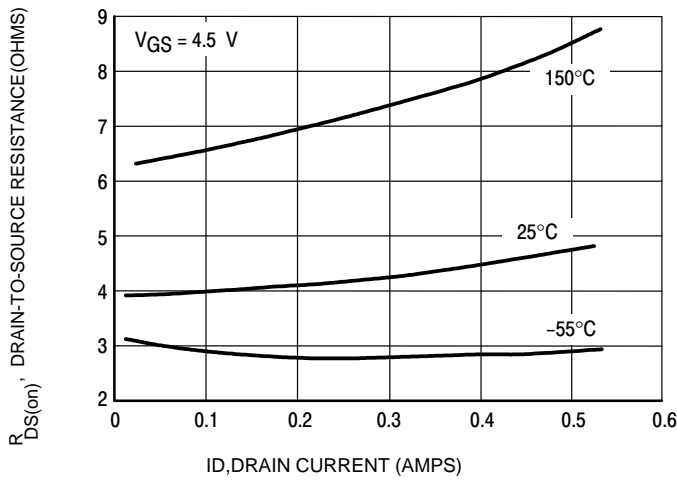

**Figure 3. On-Resistance versus Drain Current**

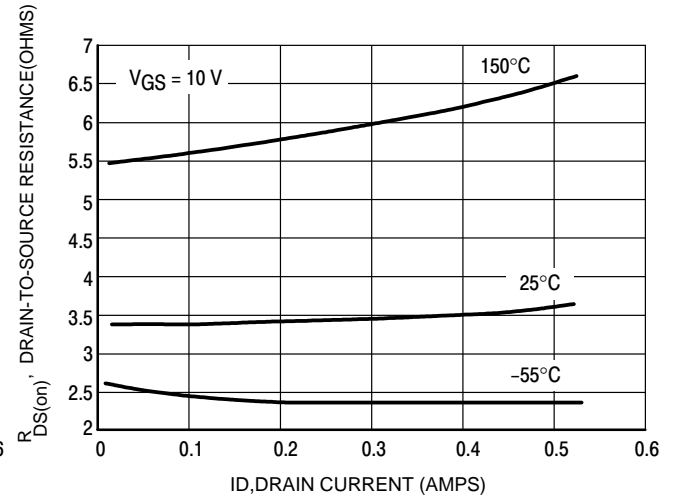

**Figure 4. On-Resistance versus Drain Current**

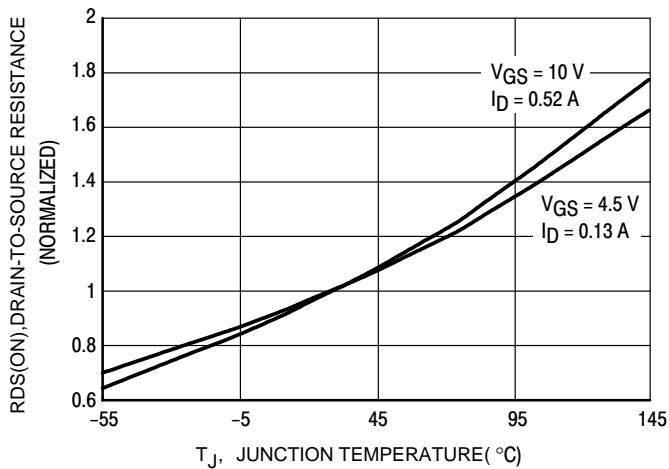

**Figure 5. On-Resistance Variation with Temperature**

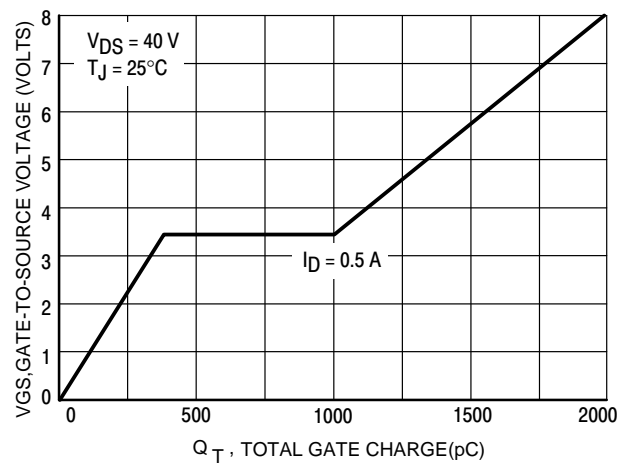

**Figure 6. Gate Charge**

Soldering parameters

Reflow Condition		Pb-Free assembly (see as below)
Pre Heat	-Temperature Min ( $T_{s(min)}$ )	+150 °C
	-Temperature Max( $T_{s(max)}$ )	+200 °C
	-Time (Min to Max) (ts)	60-180 secs.
Average ramp up rate (Liquid us Temp ( $T_L$ ) to peak)		3 °C/sec. Max
$T_{s(max)}$ to $T_L$ - Ramp-up Rate		3 °C/sec. Max
Reflow	-Temperature( $T_L$ )(Liquid us)	+217 °C
	-Temperature( $t_L$ )	60-150 secs.
Peak Temp ( $T_P$ )		+260(+0/-5) °C
Time within 5 °C of actual Peak Temp ( $t_p$ )		30 secs. Max
Ramp-down Rate		6 °C/sec. Max
Time 25 °C to Peak Temp ( $T_P$ )		8 min. Max
Do not exceed		+260 °C



Package Dimensions & Suggested Pad Layout

SOT-363

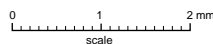
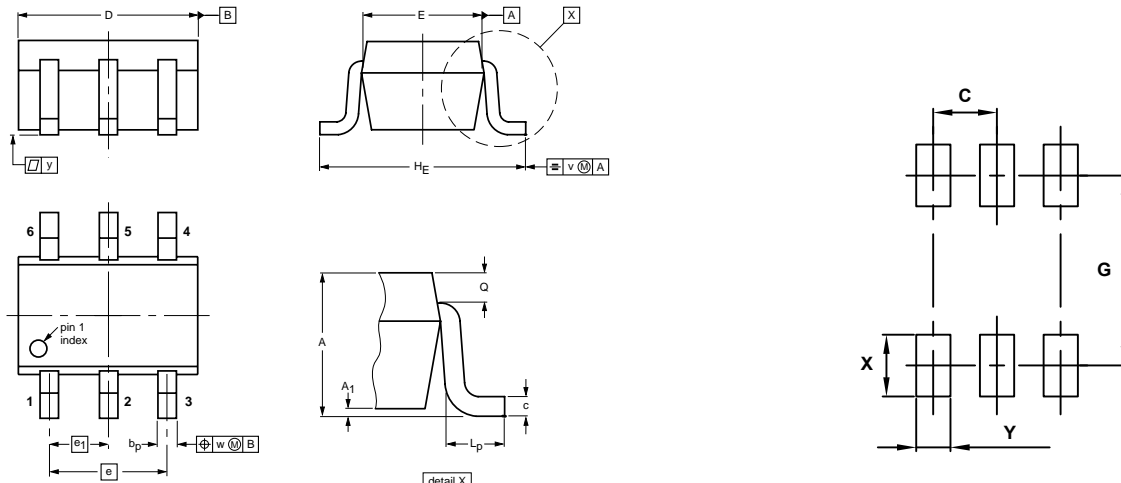

Dimensions	Value (in mm)
C	0.65
G	1.90
X	0.85
Y	0.40

DIMENSIONS (mm are the original dimensions)

UNIT	A	A1 max	bp	c	D	E	e	e1	H <sub>E</sub>	L <sub>p</sub>	Q	v	w	y
mm	1.1 0.8	0.1	0.30 0.20	0.25 0.10	2.2 1.8	1.35 1.15	1.3	0.65	2.2 2.0	0.45 0.15	0.25 0.15	0.2	0.2	0.1

Tape & reel specification

Tape

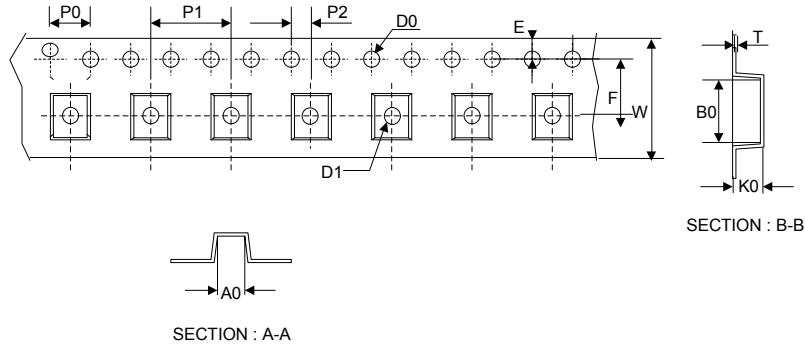

Symbol	Dimension (mm)
P0	4.00±0.20
P1	4.00±0.20
P2	2.00±0.20
D0	1.55±0.20
D1	1.00±0.20
E	1.55±0.25
F	3.60±0.20
W	8.00±0.20
A0	3.00±0.20
B0	3.00±0.20
K0	1.30±0.20
T	0.20±0.20
D2	177.0±5.0
D3	55Min.
D4	R24.6±2.0
G	R82.0±2.0
I	13.0±2.0
W1	10.20±3.0

7" Reel

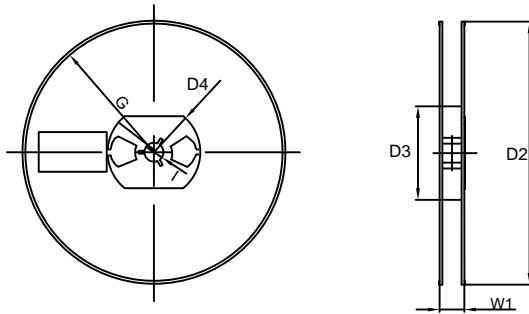

Quantity: 3000PCS