



SILERGY

SY6103

3A Fast-Response LDO Regulator

General Description

SY6103 is a 3A current capacity and low drop out voltage regulator, which features very fast transient recovery from input voltage surges and output load current changes. SY6103 with fully protection includes over current limit, output short protection, over temperature operation.

Ordering Information

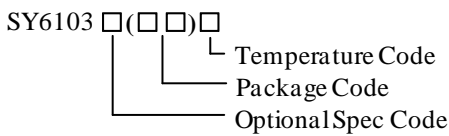

Ordering Number	Package type	Note
SY6103MAC	TO263-5	----
SY6103JBC	TO252-5	----

Features

- High Current Capability:3A Over Full Temperature Range
- Low Dropout Voltage of 480mV at Full Load 3A.
- Extremely Fast Transient Response
- Zero Current Shutdown Mode
- Adjustable Output Voltage
- Low Ground Current
- Over Current Limit
- Output Short Circuit Protection
- Over Temperature Protection
- Package: TO263-5/TO252-5
- RoHS Compliant and Halogen Free

Typical Applications

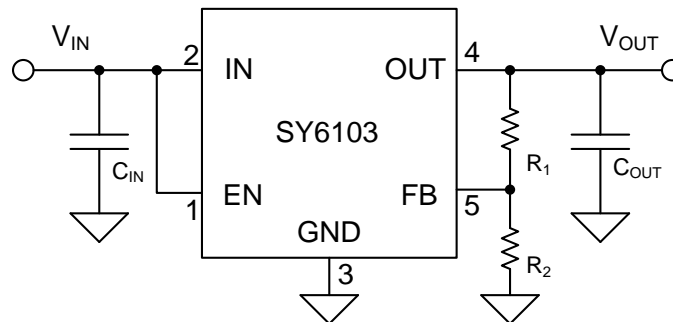
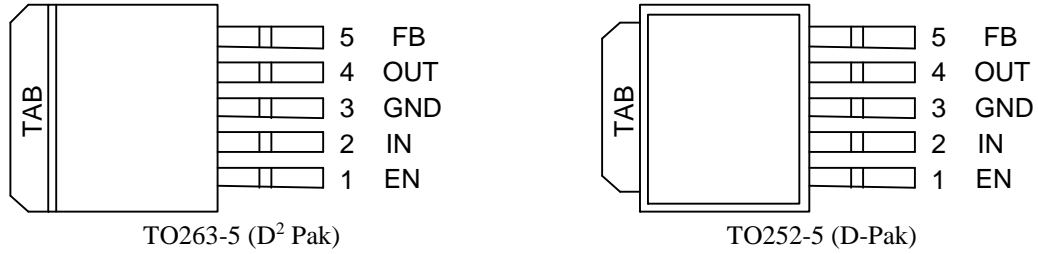

Figure1. Adjustable Output Regulator

Pinout (top view)



Part Number	Package type	Top Mark [®]
SY6103MAC	TO263-5	BIJxyz
SY6103JBC	TO252-5	BRYxyz

Note ①: x=year code, y=week code, z=lot number code.

Pin Name	Pin Number	Pin Description
1	EN	Enable (Input): Active-high CMOS compatible control input. Do not leave it floating.
2	IN	INPUT: Unregulated input, +3V to +18V maximum.
3, TAB	GND	GND: TAB is also connected internally to the IC's ground.
4	OUT	OUTPUT: The regulator output voltage.
5	FB	Feedback Voltage: 1.24V feedback from external resistor divider. $V_{OUT} = 1.24 \times \left(\frac{R_1 + R_2}{R_2} \right)$

Block Diagram

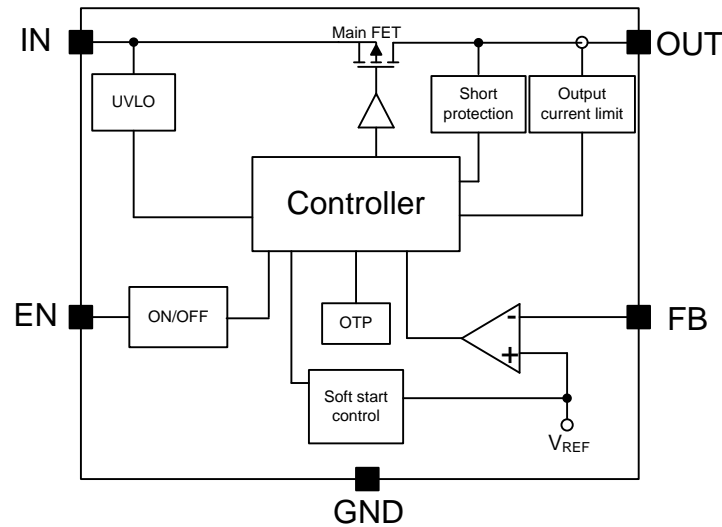

Figure2. Block Diagram

Absolute Maximum Ratings (Note 1)

IN, EN, OUT, FB-----	19V
Package Thermal Resistance (Note 2)	
TO263/TO252, θ_{JA} -----	24.5°C/W/26°C/W
TO263/TO252, θ_{JC} -----	1.4°C/W/1.2°C/W
Junction Temperature Range -----	150°C
Lead Temperature (Soldering, 10 sec.) -----	260°C
Storage Temperature Range -----	-65°C to 150°C

Recommended Operating Conditions (Note 3)

IN -----	3V to 18V
EN, OUT, FB-----	0V to 18V
Junction Temperature Range -----	-40°C to 125°C
Ambient Temperature Range -----	-40°C to 85°C

Electrical Characteristics

($V_{IN} = 5V$, $V_{OUT} = 3.3V$, $I_{OUT} = 100mA$, $T_A = -40^\circ C \sim 85^\circ C$.)

Parameter	Symbol	Test Conditions	Min	Typical	Max	Unit
General						
Input Voltage	V_{IN}		3		18	V
Input voltage UVLO Threshold	V_{UVLO}	V_{IN} rising	2.4	2.5	2.7	V
UVLO Hysteresis	V_{UVLO_th}			200		mV
Soft Start Time	t_{SS}			2	4	ms
Enable Input Logic-High Voltage	$V_{EN,H}$	$V_{IN} = V_{OUT} + 1V$	2.4			V
Enable Input Logic-Low Voltage	$V_{EN,L}$				0.8	V
Current Limit	I_{limit}		4	4.5	5	A
Thermal Shutdown Temperature	T_{SD}		130	150	170	°C
Thermal Shutdown Hysteresis	T_{HYS}			20		°C
Output short protection threshold	$V_{FB,SHORT}$		40	50	60	% V_{REF}
Output Short Off Time	t_{short_off}			38		ms
IN Pin to OUT pin Leakage Current	$I_{Leakage}$	$EN=0, V_{IN-OUT}=18V$		10	600	nA
Line Regulation	ΔV_{LNR}	$I_{OUT} = 100mA$, $(V_{OUT} + 1V) \leq V_{IN} \leq 16V$		0.1	0.5	%
Load Regulation	ΔV_{LDR}	$V_{IN} = V_{OUT} + 1V$, $100mA \leq I_{OUT} \leq 3A$		0.2	1	%

Dropout Voltage	ΔV_{DROP}	$V_{\text{FB}}=1\text{V}, I_{\text{OUT}} = 100\text{mA},$ TO263		16	24	mV
		$V_{\text{FB}}=1\text{V}, I_{\text{OUT}} = 750\text{mA},$ TO263		120	175	
		$V_{\text{FB}}=1\text{V}, I_{\text{OUT}} = 1.5\text{A},$ TO263		240	350	
		$V_{\text{FB}}=1\text{V}, I_{\text{OUT}} = 3\text{A},$ TO263		480	700	
		$V_{\text{FB}}=1\text{V}, I_{\text{OUT}} = 100\text{mA},$ TO252		11		
		$V_{\text{FB}}=1\text{V}, I_{\text{OUT}} = 750\text{mA},$ TO252		80		
		$V_{\text{FB}}=1\text{V}, I_{\text{OUT}} = 1.5\text{A},$ TO252		170		
		$V_{\text{FB}}=1\text{V}, I_{\text{OUT}} = 3\text{A},$ TO252		380		
Power Supply Rejection	PSRR	Frequency=100Hz, $C_{\text{OUT}}=10\mu\text{F}$ (Note 4)		70		dB
		Frequency=100kHz, $C_{\text{OUT}}=10\mu\text{F}$ (Note 4)		30		
Ground Current						
Ground Current	I_{GND}	IC shutdown		1	5	μA
		$I_{\text{OUT}} = 0, V_{\text{IN}}=V_{\text{OUT}}+1\text{V}$		120	150	μA
		$I_{\text{OUT}} = 1.5\text{A}, V_{\text{IN}}=V_{\text{OUT}}+1\text{V}$ (Note 4)		2	4	mA
		$I_{\text{OUT}} = 3\text{A}, V_{\text{IN}}=V_{\text{OUT}}+1\text{V}$ (Note 4)		4	8	mA
Reference Voltage						
Reference Voltage	V_{REF}		1.215	1.24	1.265	V
FB Pin Bias Current	$I_{\text{FB_Bias}}$	EN=0, FB pin floating			50	nA

Note 1: Stresses beyond “Absolute Maximum Ratings” may cause permanent damage to the device. These are for stress ratings. Functional operation of the device at these or any other conditions beyond those indicated in the operational sections of the specifications is not implied. Exposure to absolute maximum rating conditions may affect device reliability.

Note 2: θ_{JA} was measured according to JESD51-2 and chip mounted on Silergy PCB. Exposed paddle of TO263-5/TO252-5 is the case position for θ_{JC} measurement.

Note 3: The device is not guaranteed to function outside its operating conditions.

Note 4: Guaranteed by design.

Typical Performance Characteristics

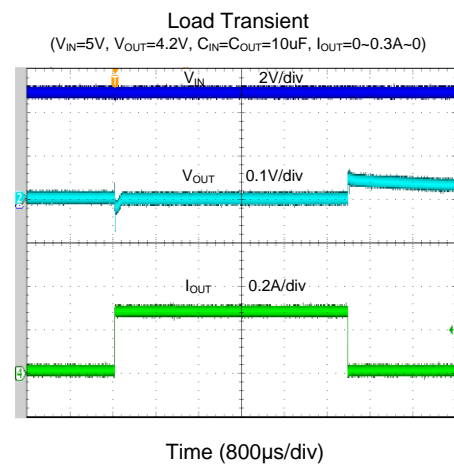
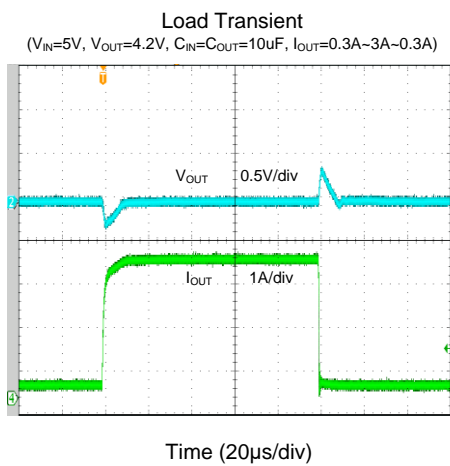
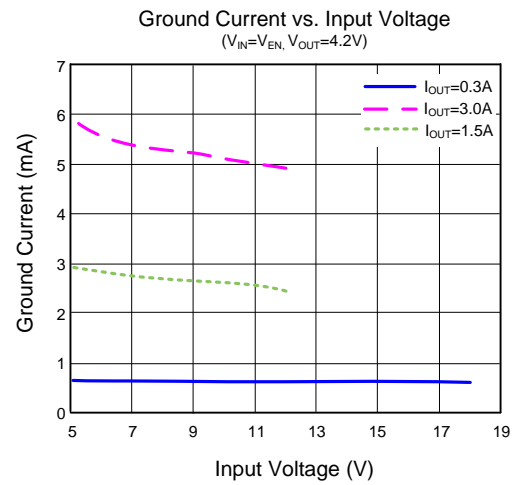
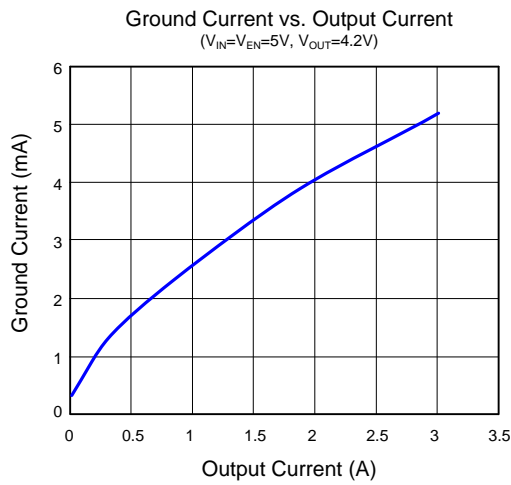
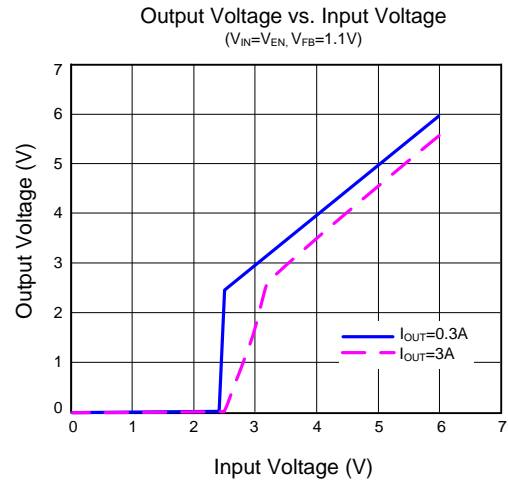
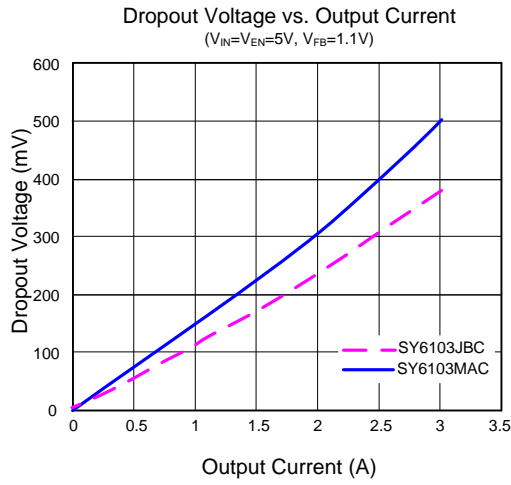

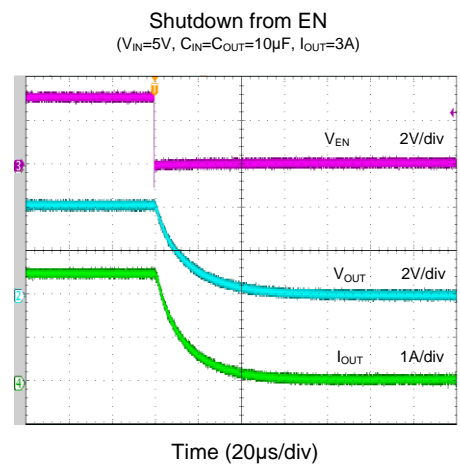
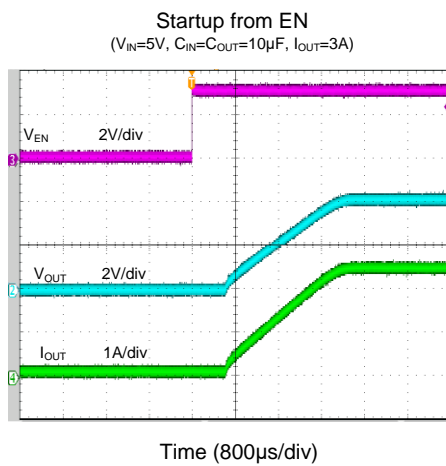
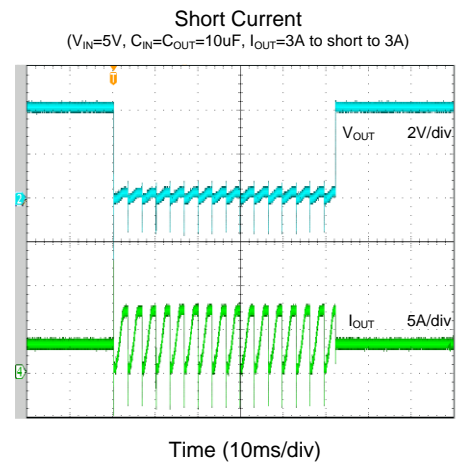
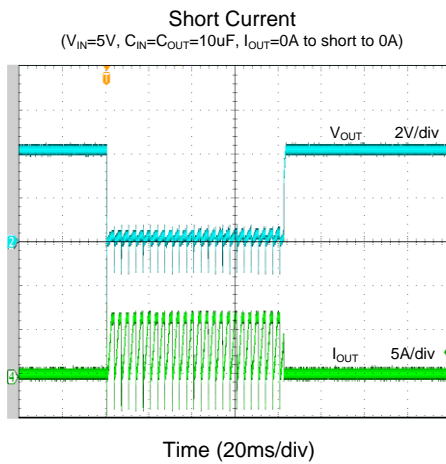
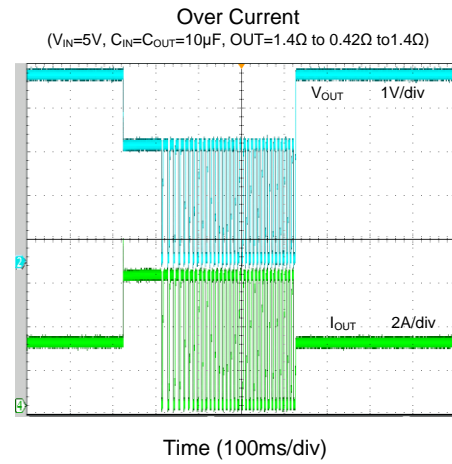
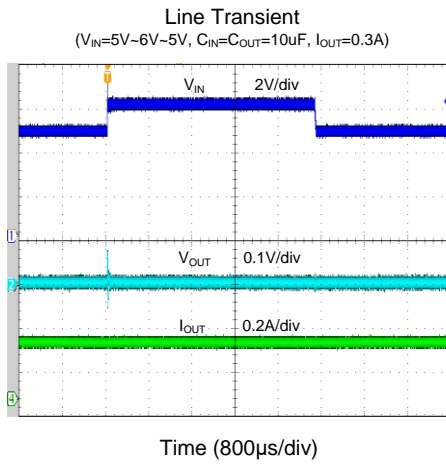

Startup from V_{IN}
 $(V_{IN}=5V, C_{IN}=C_{OUT}=10\mu F, I_{OUT}=3A)$

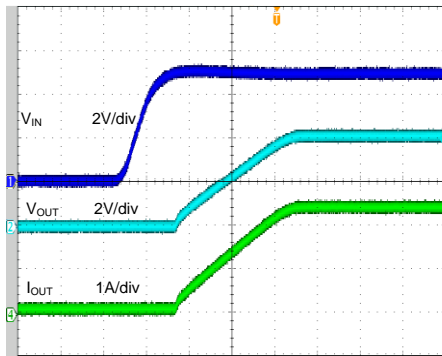

Time (800µs/div)

Shutdown from V_{IN}
 $(V_{IN}=5V, C_{IN}=C_{OUT}=10\mu F, I_{OUT}=3A)$

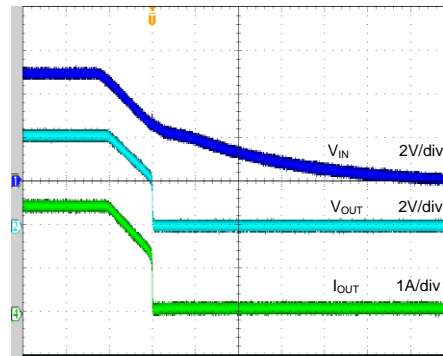

Time (2ms/div)

Power Supply Rejection Ratio
 $(V_{IN}=5V, V_{OUT}=4.2V, I_{OUT}=0.3A)$

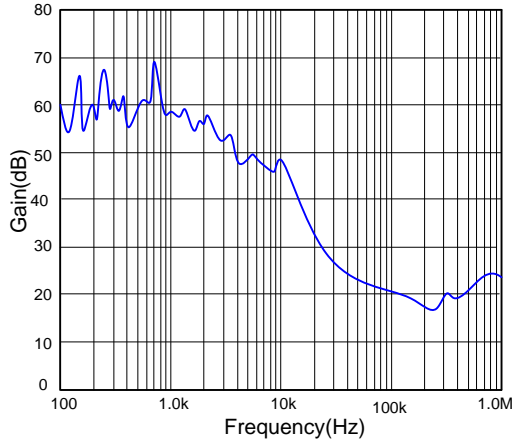

Power Supply Rejection Ratio
 $(V_{IN}=5V, V_{OUT}=4.2V, I_{OUT}=1A)$

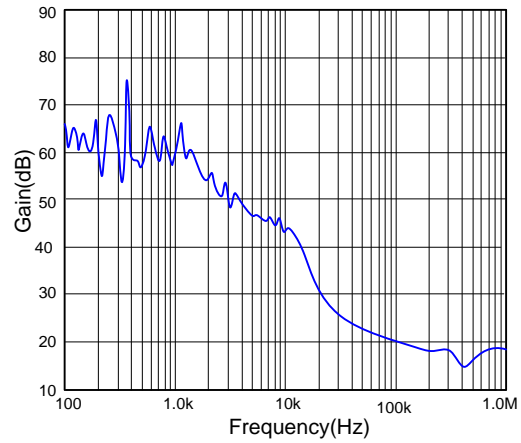

Line Regulation
 $(V_{OUT}=4.2V, C_{IN}=C_{OUT}=10\mu F, I_{OUT}=0.15A)$

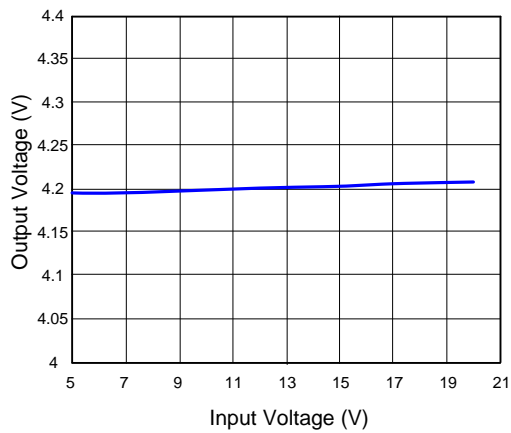

Load Regulation
 $(V_{IN}=5V, V_{OUT}=4.2V, C_{IN}=C_{OUT}=10\mu F)$

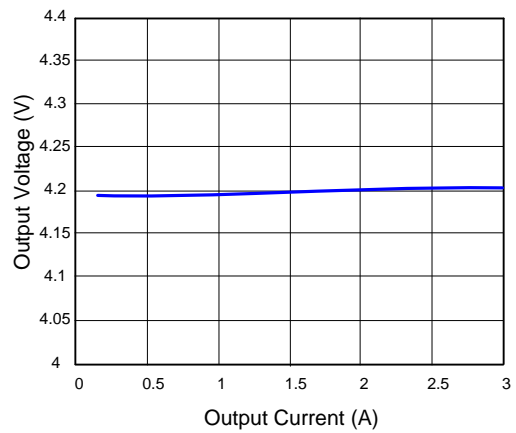

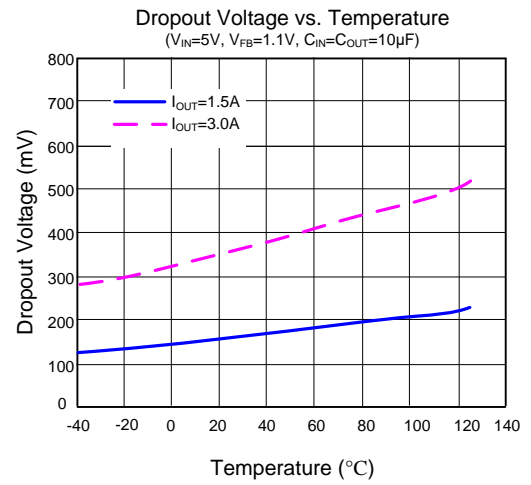
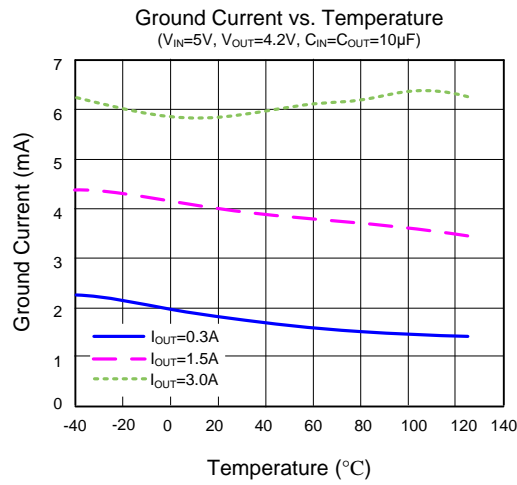
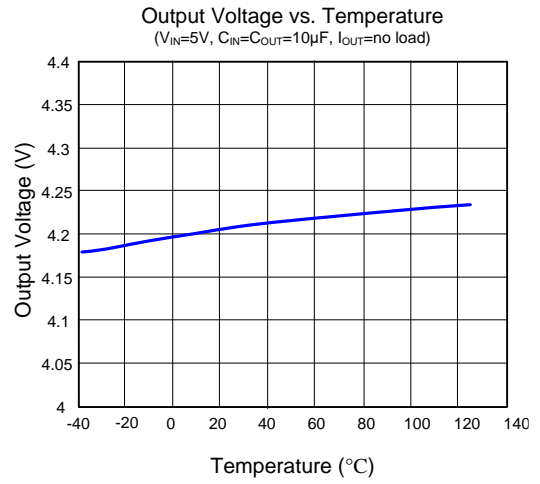
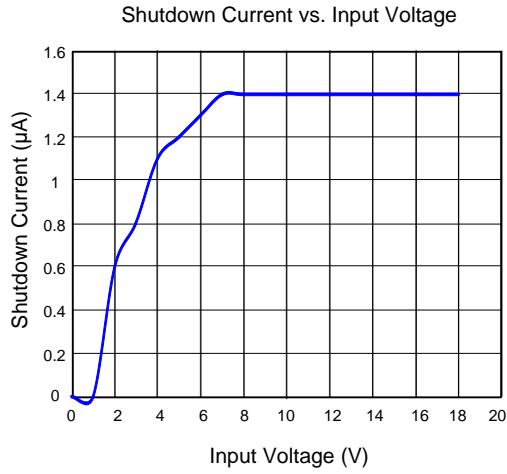

Operation Information

SY6103 is a 3A current capacity and low dropout voltage regulator, which features very fast transient recovery from input voltage surges and output load current changes. SY6103 with fully protection includes over current limit, output short protection, over input voltage protection and over temperature operation.

Input Capacitor C_{IN}

An input capacitance about 10μF is required between the device input pin and ground pin. A typical X5R or better grade ceramic capacitor with 25V rating is recommended in this application. This input capacitor must be located close to the device to assure input stability. A lower ESR capacitor allows the use of less capacitance, while higher ESR type requires more capacitance.

Output Capacitor C_{OUT}

For transient stability, SY6103 is designed specifically to work with very small ceramic output capacitors. 2.2μF output capacitance can be used in this application. Higher capacitance values help to improve transient. The output capacitor's ESR is critical because it forms a zero to provide phase lead which is required for loop stability.

Output Voltage Setting

Choose R2 and R3 to program the proper output voltage. To minimize the power consumption under light loads, it is desirable to choose large resistance values for both R2 and R3. A value of between 1kΩ and 1MΩ is highly recommended for both resistors. The complete equation for the output voltage is described as follows;

$$V_{OUT} = 1.24 \times \frac{R_3 + R_2}{R_2}$$

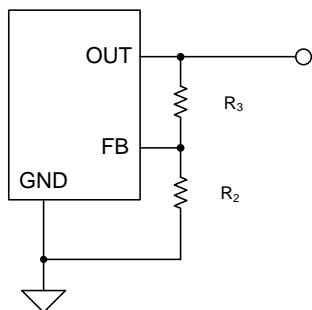

No Load Stability

The device will remain stable and in regulation with no external load. This is especially important in CMOS RAM keep-alive applications.

Dropout Voltage

SY6103 has a very low dropout voltage due to its extra low R_{DS(ON)} of the main PMOS determines the lowest usable supply.

$$V_{DROPOUT} = V_{IN} - V_{OUT} = R_{DS(ON)} \times I_{OUT}$$

Over Current and Short Circuit Protection

The minimum current limit of SY6103 is 4A. The device includes over current and short circuit protection. The current limitation circuit regulates the output current to its limitation threshold to protect IC from damage. Under over current or short circuit condition, the power loss of the IC is relative high. And that may trigger the thermal protection.

Load Transient Considerations

The SY6103 regulator IC integrates the compensation components to achieve good stability and fast transient responses. In some applications, adding a small ceramic capacitor in parallel with R1 may further speed up the load transient responses and is thus recommended for applications with large load transient step requirements.

Thermal Considerations

The SY6103 can deliver a current of up to 3A over the full operating junction temperature range. However, the maximum output current must be derated at higher ambient temperature to ensure the junction temperature does not exceed 125°C. With all possible conditions, the junction temperature must be within the range specified under operating conditions. Power dissipation can be calculated based on the output current and the voltage drop across regulator.

$$P_D = (V_{IN} - V_{OUT}) \times I_{OUT} + V_{IN} \times I_{GND}$$

The final operating junction temperature for any set of conditions can be estimated by the following thermal equation:

$$P_{D(MAX)} = (T_{J(MAX)} - T_A) / \theta_{JA}$$

Where T_{J(MAX)} is the maximum junction temperature of die (125°C) and T_A is the maximum ambient temperature.

Layout Design

Good board layout practices must be used or instability can be induced because of ground loops and voltage drops, and large PCB copper area can improve the thermal performance. The input and output capacitors MUST be directly connected to the

input, output, and ground pins of the device using traces which have no other currents flowing through them. The feedback loop formed by R_1 , R_2 and the trace connecting to the FB pin and OUT must be minimize. The best way to do this is to layout C_{IN} and C_{OUT} near the device with short traces to the V_{IN} , V_{OUT} , and ground pins. The regulator ground pin

should be connected to the external circuit ground so that the regulator and its capacitors have a “single point ground.”

Below is the recommended PCB Layout diagram:

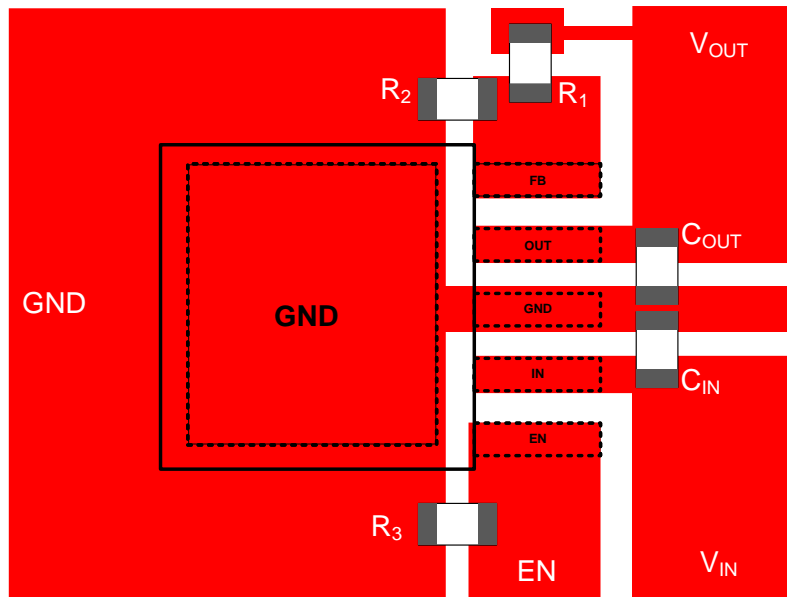
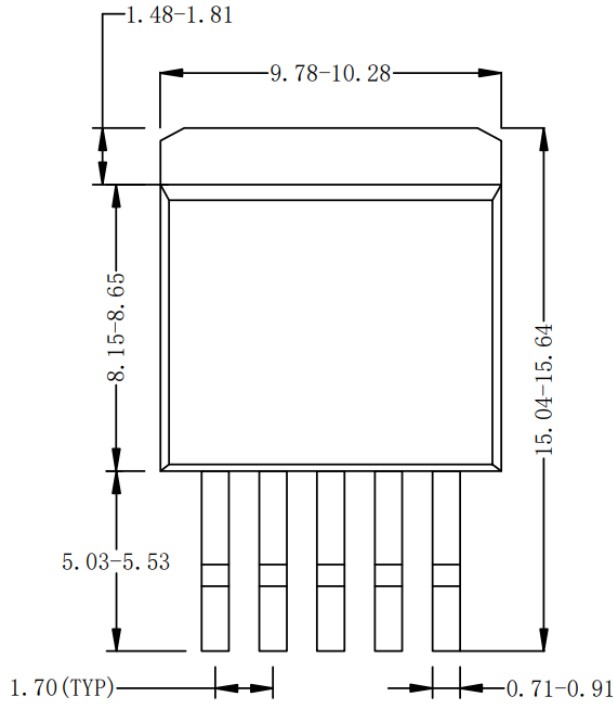
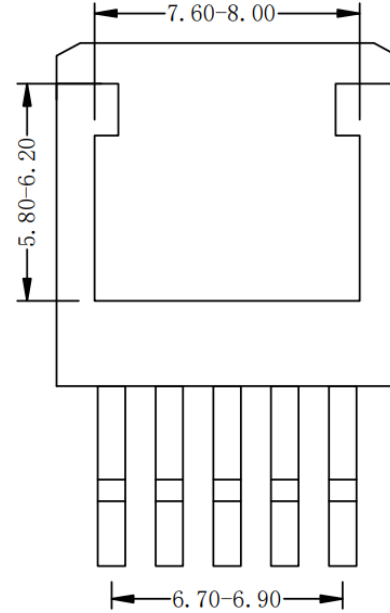

Figure3. PCB Layout Suggestion

TO263-5 Package Outline Drawing



Top View



Bottom View

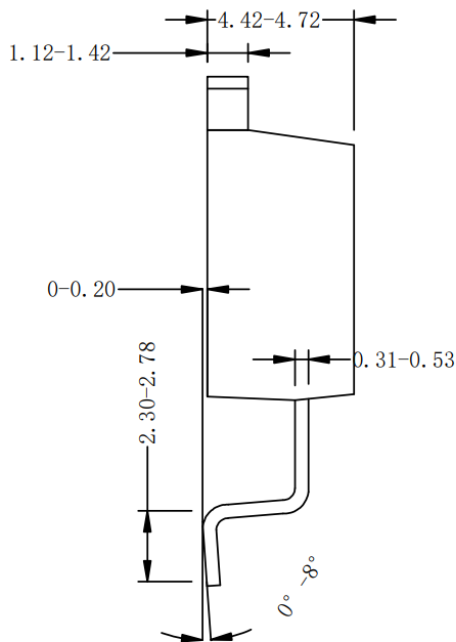

Side View

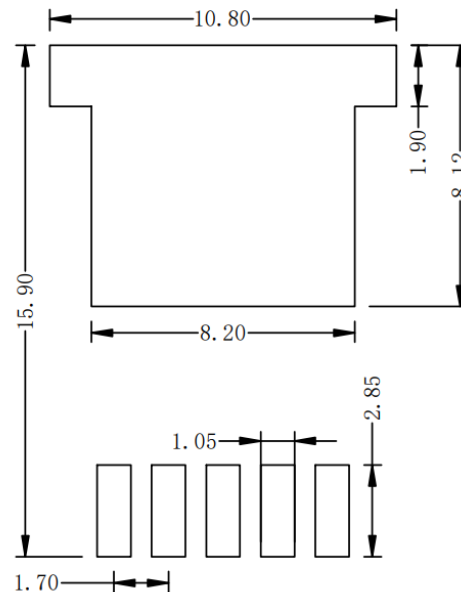

**Recommended PCB Layout
(Reference only)**

Notes: All dimension in millimeter and exclude mold flash & metal burr.

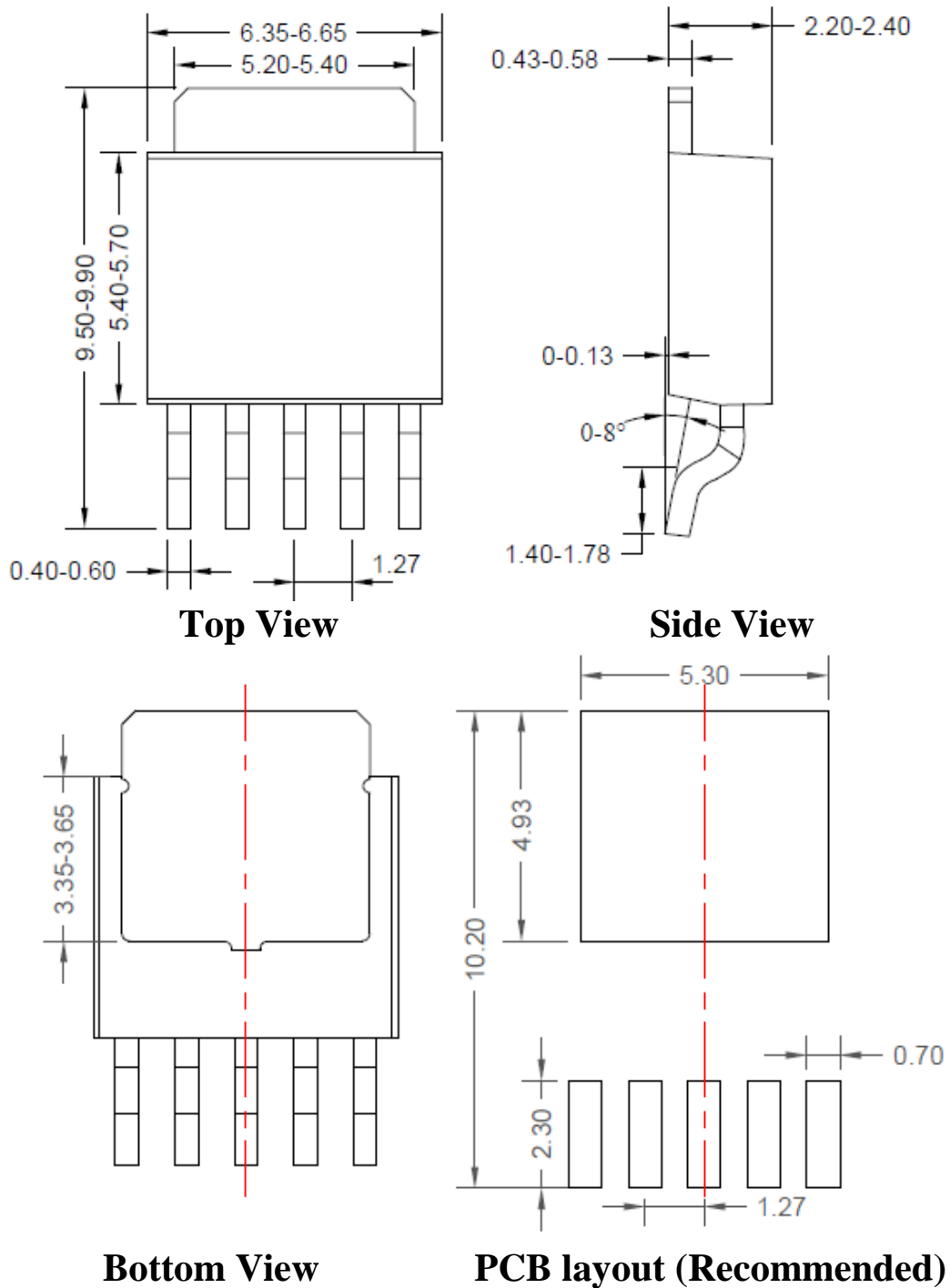
TO252-5 Package Outline & PCB Layout

- Notes:**
- 1, All dimension in MM and exclude mold flash & metal burr**
 - 2, Recommended PCB layout only for reference.**

Taping & Reel Specification

1. Taping Orientation for Packages

TO252-5, TO263-5

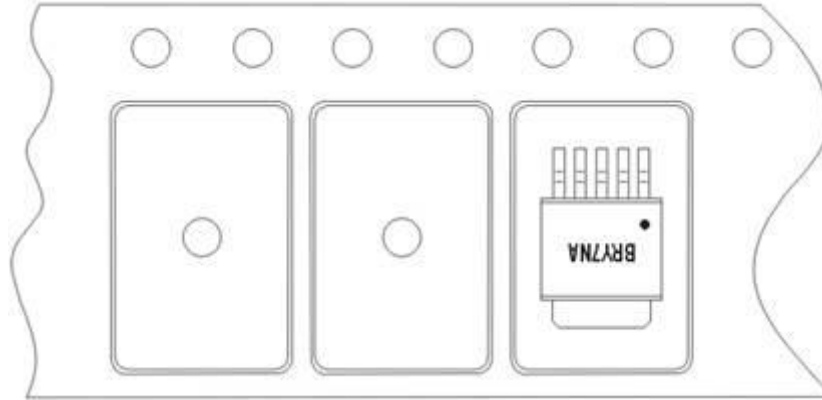

Feeding direction →

2. Carrier Tape & Reel specification for packages

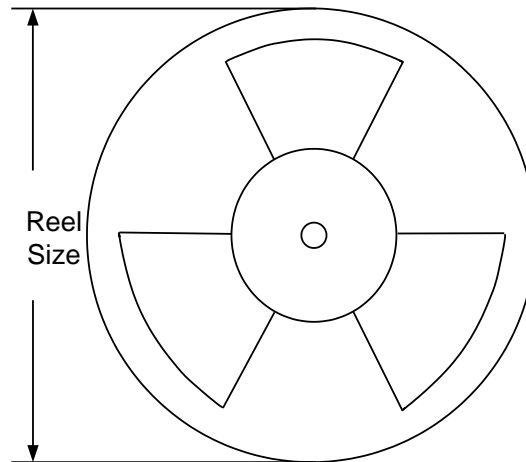

Package type	Tape width (mm)	Pocket pitch(mm)	Reel size (Inch)	Trailer length(mm)	Leader length (mm)	Qty per reel(pcs)
TO263-5	12	8	13"	400	400	800
TO252-5	12	8	13"	400	400	2500

3. Others: NA

Revision History

The revision history provided is for informational purpose only and is believed to be accurate, however, not warranted. Please make sure that you have the latest revision.

Date	Revision	Change
Dec.03, 2024	Revision 1.0A	Update the package outline for TO263-5 (page11)
Jun.17, 2021	Revision 0.9A	Update the package outline for TO252-5 (page12).
Dec.27, 2017	Revision 0.9	Initial Release

IMPORTANT NOTICE

- 1. Right to make changes.** Silergy and its subsidiaries (hereafter Silergy) reserve the right to change any information published in this document, including but not limited to circuitry, specification and/or product design, manufacturing or descriptions, at any time and without notice. This document supersedes and replaces all information supplied prior to the publication hereof. Buyers should obtain the latest relevant information before placing orders and should verify that such information is current and complete. All semiconductor products are sold subject to Silergy’s standard terms and conditions of sale.
- 2. Applications.** Application examples that are described herein for any of these products are for illustrative purposes only. Silergy makes no representation or warranty that such applications will be suitable for the specified use without further testing or modification. Buyers are responsible for the design and operation of their applications and products using Silergy products. Silergy or its subsidiaries assume no liability for any application assistance or designs of customer products. It is customer’s sole responsibility to determine whether the Silergy product is suitable and fit for the customer’s applications and products planned. To minimize the risks associated with customer’s products and applications, customer should provide adequate design and operating safeguards. Customer represents and agrees that it has all the necessary expertise to create and implement safeguards which anticipate dangerous consequences of failures, monitor failures and their consequences, lessen the likelihood of failures that might cause harm and take appropriate remedial actions. Silergy assumes no liability related to any default, damage, costs or problem in the customer’s applications or products, or the application or use by customer’s third-party buyers. Customer will fully indemnify Silergy, its subsidiaries, and their representatives against any damages arising out of the use of any Silergy components in safety-critical applications. It is also buyers’ sole responsibility to warrant and guarantee that any intellectual property rights of a third party are not infringed upon when integrating Silergy products into any application. Silergy assumes no responsibility for any said applications or for any use of any circuitry other than circuitry entirely embodied in a Silergy product.
- 3. Limited warranty and liability.** Information furnished by Silergy in this document is believed to be accurate and reliable. However, Silergy makes no representation or warranty, expressed or implied, as to the accuracy or completeness of such information and shall have no liability for the consequences of use of such information. In no event shall Silergy be liable for any indirect, incidental, punitive, special or consequential damages, including but not limited to lost profits, lost savings, business interruption, costs related to the removal or replacement of any products or rework charges, whether or not such damages are based on tort or negligence, warranty, breach of contract or any other legal theory. Notwithstanding any damages that customer might incur for any reason whatsoever, Silergy’ aggregate and cumulative liability towards customer for the products described herein shall be limited in accordance with the Standard Terms and Conditions of Sale of Silergy.
- 4. Suitability for use.** Customer acknowledges and agrees that it is solely responsible for compliance with all legal, regulatory and safety-related requirements concerning its products, and any use of Silergy components in its applications, notwithstanding any applications-related information or support that may be provided by Silergy. Silergy products are not designed, authorized or warranted to be suitable for use in life support, life-critical or safety-critical systems or equipment, nor in applications where failure or malfunction of a Silergy product can reasonably be expected to result in personal injury, death or severe property or environmental damage. Silergy assumes no liability for inclusion and/or use of Silergy products in such equipment or applications and therefore such inclusion and/or use is at the customer’s own risk.
- 5. Terms and conditions of commercial sale.** Silergy products are sold subject to the standard terms and conditions of commercial sale, as published at <http://www.silergy.com/stdterms>, unless otherwise agreed in a valid written individual agreement specifically agreed to in writing by an authorized officer of Silergy. In case an individual agreement is concluded only the terms and conditions of the respective agreement shall apply. Silergy hereby expressly objects to and denies the application of any customer’s general terms and conditions with regard to the purchase of Silergy products by the customer.
- 6. No offer to sell or license.** Nothing in this document may be interpreted or construed as an offer to sell products that is open for acceptance or the grant, conveyance or implication of any license under any copyrights, patents or other industrial or intellectual property rights. Silergy makes no representation or warranty that any license, either express or implied, is granted under any patent right, copyright, mask work right, or other intellectual property right. Information published by Silergy regarding third-party products or services does not constitute a license to use such products or services or a warranty or endorsement thereof. Use of such information may require a license from a third party under the patents or other intellectual property of the third party, or a license from Silergy under the patents or other intellectual property of Silergy.

For more information, please visit: www.silergy.com

© 2024 Silergy Corp.

All Rights Reserved.