

修订 REV NO	标记 MARK	修改摘要 REVISION DESCRIPTION	签名 SIGNATURE	日期 DATE
		NEW DWG		2016-03-12

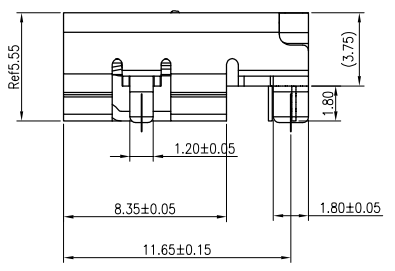
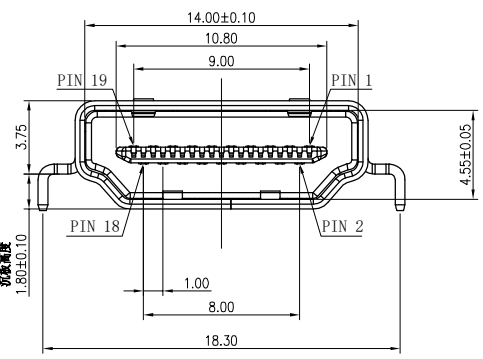
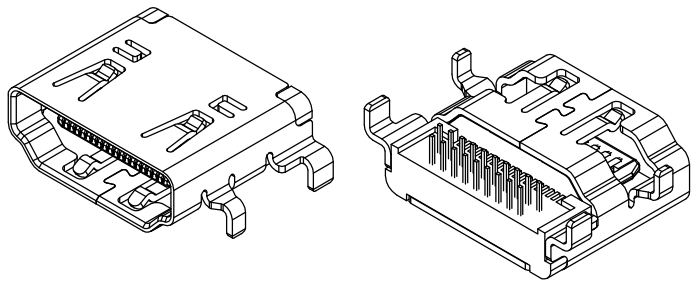
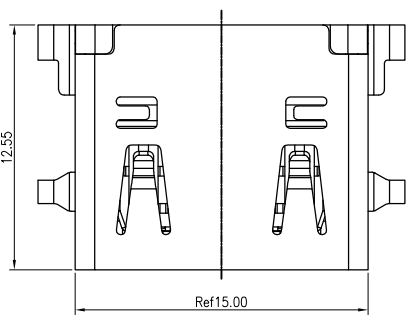

Notes:

1. materials:

- a. housing: Thermoplastic (UL94V-0)
- b. terminal: Copper alloy. Gold plated on contact area.
- c. Shell: Copper ally/SPCC, Nickel plated overall.

2. Specification

- a. Current rating: 0.5A, MAX
- b. Dielectric withstanding voltage;
- c. Insulation resistance: 100MΩ Min (unmated) At 500V DC.
- d. Contact resistance: 30mΩ Max.
- e. Operating temperature: -25° C to +85° C.

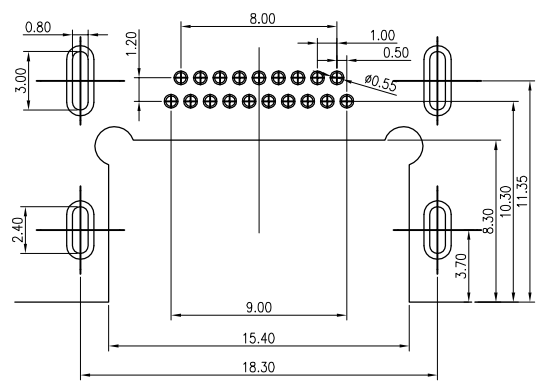
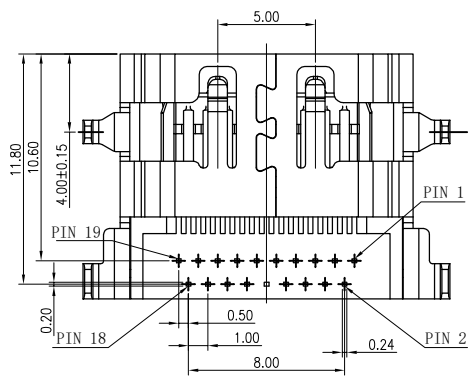

RECOMMEND P.C.B LAYOUT (COMPONENT SIDE)
TOLERANCE FOR PCB LAYOUT IS ± 0.05

PIN	Signal Assignment
1	TMDS Data2+
2	TMDS Data2 Shield
3	TMDS Data2-
4	TMDS Data1+
5	TMDS Data1 Shield
6	TMDS Data1-
7	TMDS Data0+
8	TMDS Data0 Shield
9	TMDS Data0-
10	TMDS Clock+
11	TMDS Clock Shield
12	TMDS Clock-
13	CEC
14	Utility
15	SCL
16	SDA
17	DDC/CEC Ground
18	+5V Power
19	Hot Plug Detect

PIN	Signal Assignment
2	TMDS Data2 Shield
4	TMDS Data1+
6	TMDS Data1-
8	TMDS Data0 Shield
10	TMDS Clock+
12	TMDS Clock-
14	Utility
16	SDA
18	+5V Power



深圳市华德共创科技有限公司
Shenzhen Huade co-create Technology Co., LTD
电话: 0755-27111216 传真: 0755-29940187

-TOLERANCES- UNLESS OTHERWISE SPECIFIED 公差参数表		TITLE: 产品名称: HDMI A TYPE母座沉板3.75MM卧式插板	
X.X ±0.30	X.X* ±3°	APPD: 核准:	PART NO: 产品编号: HDMI-DB-126PB
X.XX ±0.20	X.XX* ±2°	CHECK: 校对: 王建业	DATE SCALE UNIT CODE NUMBER
X.XXX ±0.10	X.XXX* ±1°	DRAW: 绘图: 黄艳兰	2016-03-12 1:1 mm A001

修訂 REV A0	标记 MARK	修改摘要 REVISION DESCRIPTION	签名 SIGNATURE	日期 DATE
		NEW DWG		2016-03-12

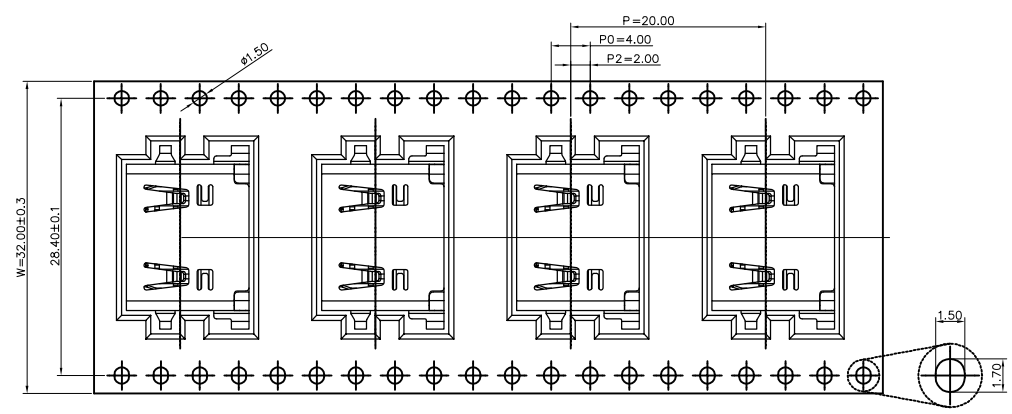
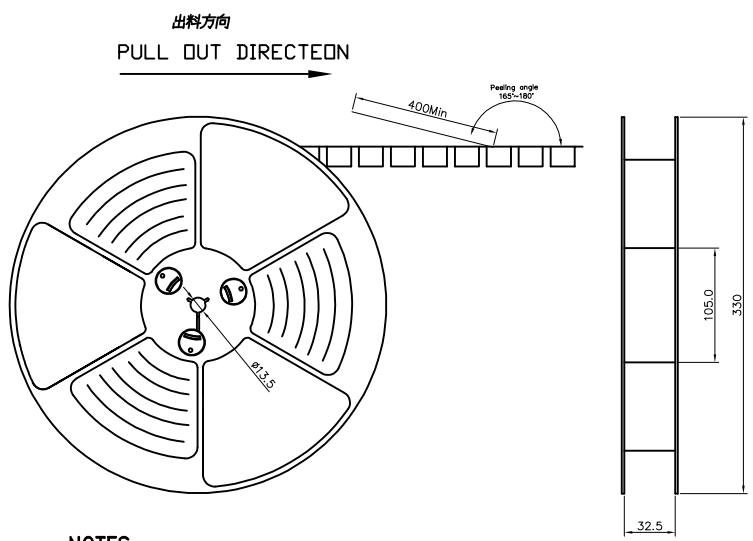

NOTES

1.帶子引導長度
LEAD TAPE LENGTH
出料方向
PULL OUT DIRECTEON

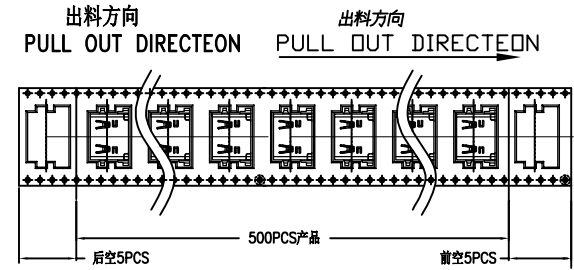

2.上帶 剝力力為: 0.1~1.3N(10.2gf~130gf)
PEELING OFF FORCE OF TOP TAPE:0.1~1.3N(10.2gf~130gf)
出貨 運輸過程中一定注意:
THIS REQUIREMENT SHOULD BE APPLIED AT SHIPMENT:
卷帶在運輸過程中不能散開
PEELING OFF SHOULD NOT BE ALLOWED DURING TRANSPORTATION

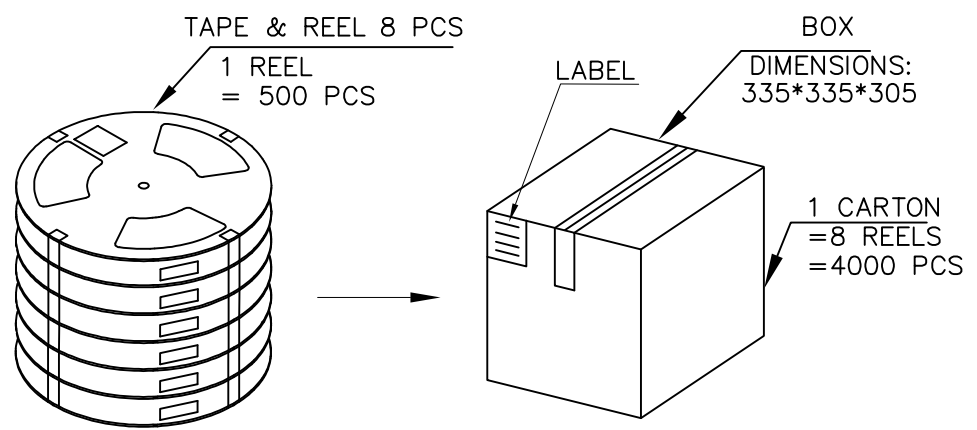

包裝明細表 (The detail of the packing) Carton						
產品料號 (Product No.)	包裝容量 (Packing Capacity)			重量 Weight (Kg)		
	pcs/box	boxs/Carton	Pcs/Box	N.W./Pcs	N.W./Box	G.W./Box
HDMI-DB-126PB	500	8	4000	---	---	---

		深圳市華德共創科技有限公司 Shenzhen Huade co-create Technology Co.,LTD 電話: 0755-27111216 傳真: 0755-29940187			
-TOLERANCES- UNLESS OTHERWISE SPECIFIED 公差參數表				TITLE: HDMI A TYPE母座沉板3.75MM卧式插板 產品名稱:	
X.X	±0.30	X.X*	±3'	APPD: 核准:	PART NO: HDMI-DB-126PB 產品編號:
X.XX	±0.20	X.XX*	±2'	CHECK: 校對: 王建業	DATE SCALE UNIT CODE NUMBER
X.XXX	±0.10	X.XXX*	±1'	DRAW: 繪圖: 黃艷蘭	2016-03-12 1:1 mm A001