

48V, Low Noise, Precision Operational Amplifiers

Features and Benefits

- Wide Supply: $\pm 2.25\text{ V}$ to $\pm 24\text{ V}$, 4.5 V to 48 V
- Low Offset Voltage: $\pm 100\ \mu\text{V}$ Maximum
- Low Offset Voltage Drift: $\pm 1\ \mu\text{V}/^\circ\text{C}$
- Bandwidth: 1.1 MHz GBW
- Slew Rate: $0.8\text{ V}/\mu\text{s}$
- Low Noise: $22\text{ nV}/\sqrt{\text{Hz}}$ at 10 kHz
- High Common-Mode Rejection: 110 dB
- Low Bias Current: $\pm 20\text{ pA}$
- EMI/RFI Filtered Inputs

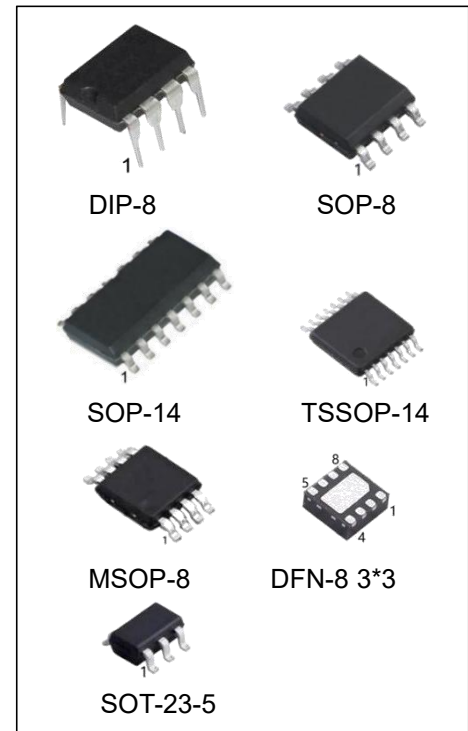

Ordering Information

DEVICE	Package Type	MARKING	Packing	Packing Qty
OPA703NAM5/TR-HG	SOT-23-5	A703	REEL	3000pcs/reel
OPA703UAM/TR-HG	SOP-8	A703	REEL	2500pcs/reel
OPA703PAN/HG	DIP-8	A703	REEL	2500pcs/reel
OPA2703UAM/TR-HG	SOP-8	A2703	REEL	2500pcs/reel
OPA2703EAMM/TR-HG	MSOP-8	A2703	REEL	3000pcs/reel
OPA2703DQ3/TR-HG	DFN-8	A2703	REEL	5000pcs/reel
OPA2703PAN/HG	DIP-8	A2703	REEL	2500pcs/reel
OPA4703UAM/TR-HG	SOP-14	OPA4703	REEL	2500pcs/reel
OPA4703EAM/TR-HG	TSSOP-14	OPA4703	REEL	2500pcs/reel

General Description

The OPAx703 family (OPA703, OPA2703, and OPA4703) is a new generation of high voltage (48 V), low noise, precision operational amplifiers. These devices offer outstanding dc precision and ac performance, include low offset ($\pm 100 \mu\text{V}$ maximum), low drift ($\pm 1 \mu\text{V}/^\circ\text{C}$), 1.1-MHz bandwidth, and $22 \text{ nV}/\sqrt{\text{Hz}}$ Input voltage noise density at 10 kHz. Unique features such as differential input-voltage range to the negative supply rail, high output current ($\pm 40 \text{ mA}$), and high capacitive load drive of up to 1 nF make the OPAx703 high-performance op-amps for high-voltage industrial applications.

The robust design of the OPAx703 family provides ease-of-use to the circuit designer: integrated RF/EMI rejection filter, no phase reversal in overdrive conditions, and high electro-static discharge (ESD) protection. The OPAx703 are optimized for operation at voltages from +4.5 V ($\pm 2.25 \text{ V}$) to +48 V ($\pm 24 \text{ V}$) over the extended temperature range of -40°C to $+125^\circ\text{C}$.

The OPA703 (single) is available in both SOT-23-5, DIP-8 and SOP-8 packages. The OPA2703 (dual) is offered in SOP-8, DFN-8 and MSOP-8 packages. The quad-channel OPA4703 is offered in both SOP-14 and TSSOP-14 packages.

Applications

- High-side and low-side current sensing
- Analog input and output modules
- ADC driver and reference buffer amplifier
- High Precision Comparator
- Power delivery: UPS, server, and merchant network power
- Multiplexed Data-Acquisition Systems
- Test and Measurement Equipment
- Programmable Logic Controllers

Pin Configuration (Top View)

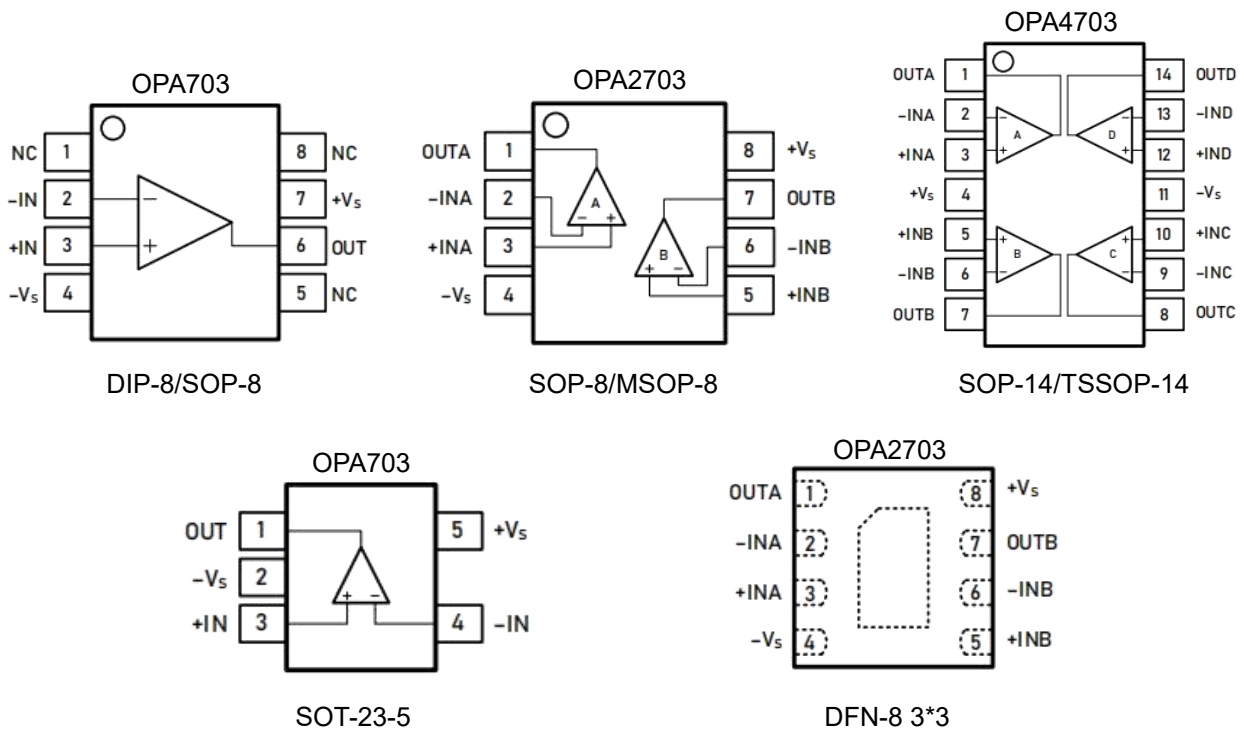

Pin Description

Symbol	Description
-IN	Inverting input of the amplifier. The voltage range is from V_{S-} to $V_{S+} - 2V$.
+IN	Non-inverting input of the amplifier. This pin has the same voltage range as -IN.
+Vs	Positive power supply. The voltage is from 4.5V to 48V. Split supplies are possible as long as the voltage between V_{S+} and V_{S-} is from 4.5V to 48V.
-Vs	Negative power supply. It is normally tied to ground. It can also be tied to a voltage other than ground as long as the voltage between V_{S+} and V_{S-} is from 4.5V to 48V.
OUT	Amplifier output.
NC	No connection

Limiting Value

In accordance with the Absolute Maximum Rating System (IEC 60134).

Parameter	Absolute Maximum Rating
Supply Voltage, VS+ to VS-	60 V
Signal Input Terminals: Voltage, Current	-VS - 0.3V to +VS + 0.3V, ±10 mA
Output Short-Circuit	Continuous
Storage Temperature Range, Tstg	-65 °C to +150 °C
Operating Temperature Range ⁽¹⁾ , TA	-40 °C to +125 °C
Junction Temperature, TJ	150 °C
Lead Temperature Range (Soldering 10 sec)	260 °C

Note: Stress greater than those listed under Absolute Maximum Ratings may cause permanent damage to the device. This is a stress rating only and functional operation of the device at these or any other conditions outside those indicated in the operational sections of this specification are not implied. Exposure to absolute maximum rating conditions for extended periods may affect reliability.

(1) Operating temperature range: -40°C to +125°C. This product is designed for industrial grade applications. For automotive grade versions compliant with AEC-Q100, please conduct internal screening per the standard or contact our sales team for availability.

ESD Rating

Parameter	Item	Value	Unit
Electrostatic Discharge Voltage	Human body model (HBM), per MIL-STD-883J / Method 3015.9 ⁽¹⁾	±1 500	V
	Charged device model (CDM), per ESDA/JEDEC JS-002-2014 ⁽²⁾	±1 000	
	Machine model (MM), per JESD22-A115C	±400	

(1) JEDEC document JEP155 states that 500-V HBM allows safe manufacturing with a standard ESD control process. Manufacturing with less than 500-V HBM is possible if necessary precautions are taken.

(2) JEDEC document JEP157 states that 250-V CDM allows safe manufacturing with a standard ESD control process. Manufacturing with less than 250-V CDM is possible if necessary precautions are taken.

Electrical Characteristics

$V_S = 4.5\text{ V to }48\text{ V}$, $T_A = +25\text{ }^\circ\text{C}$, $V_{CM} = V_S/2$, $V_O = V_S/2$, and $R_L = 10\text{ k}\Omega$ connected to $V_S/2$, unless otherwise noted. Boldface limits apply over the specified temperature range, $T_A = -40\text{ }^\circ\text{C to }+125\text{ }^\circ\text{C}$.

Symbol	Parameter	Conditions	Min.	Typ.	Max.	Unit
OFFSET VOLTAGE						
V_{OS}	Input offset voltage				± 100	μV
V_{OSTC}	Offset voltage drift	$T_A = -40\text{ to }+125\text{ }^\circ\text{C}$		± 1		$\mu\text{V}/^\circ\text{C}$
PSRR	Power supply rejection ratio	$V_S = 4.5\text{ to }44\text{ V}$, $V_{CM} = 0.1\text{ V}$		2		$\mu\text{V}/\text{V}$
		$T_A = -40\text{ to }+125\text{ }^\circ\text{C}$		6		
INPUT BIAS CURRENT						
I_B	Input bias current			20		pA
		$T_A = +85\text{ }^\circ\text{C}$		150		
		$T_A = +125\text{ }^\circ\text{C}$		600		
I_{OS}	Input offset current			10		pA
NOISE						
V_n	Input voltage noise	$f = 0.1\text{ to }10\text{ Hz}$		4		μV_{P-P}
e_n	Input voltage noise density	$f = 1\text{ kHz}$		25		$\text{nV}/\sqrt{\text{Hz}}$
		$f = 10\text{ kHz}$		22		
I_n	Input current noise density	$f = 1\text{ kHz}$		5		$\text{fA}/\sqrt{\text{Hz}}$
INPUT VOLTAGE						
V_{CM}	Common-mode voltage range		$-V_S$		$+V_S-2$	V
CMRR	Common-mode rejection ratio	$V_S = 40\text{ V}$, $V_{CM} = 0\text{ to }38\text{ V}$		110		dB
		$V_{CM} = 0.1\text{ to }38\text{ V}$, $T_A = -40\text{ to }+125\text{ }^\circ\text{C}$		98		
		$V_S = 5.0\text{ V}$, $V_{CM} = 0\text{ to }3\text{ V}$		85		
		$V_{CM} = 0.1\text{ to }3\text{ V}$, $T_A = -40\text{ to }+125\text{ }^\circ\text{C}$		72		
INPUT IMPEDANCE						
CIN	Input capacitance	Differential		2.0		pF
		Common mode		3.5		
OPEN-LOOP GAIN						
A_{VOL}	Open-loop voltage gain	$V_S = 40\text{ V}$, $V_O = 0.1\text{ to }39.9\text{ V}$		116		dB
		$T_A = -40\text{ to }+125\text{ }^\circ\text{C}$		112		
		$V_S = 5\text{ V}$, $V_O = 0.1\text{ to }4.9\text{ V}$		101		
		$T_A = -40\text{ to }+125\text{ }^\circ\text{C}$		97		
FREQUENCY RESPONSE						
GBW	Gain bandwidth product			1.1		MHz
SR	Slew rate	$V_S = 40\text{ V}$, $G = +1$, 10 V step		0.8		$\text{V}/\mu\text{s}$

THD+N	Total harmonic distortion + noise	$G = +1, f = 1 \text{ kHz}, V_O = 3 \text{ VRMS}$		0.02		%
t_s	Settling time	To 0.1%, $V_S = 40 \text{ V}, G = +1, 5 \text{ V step}$		6		μs
		To 0.01%, $V_S = 40 \text{ V}, G = +1, 5 \text{ V step}$		12		
t_{OR}	Overload recovery time	$V_{IN} \times \text{Gain} > V_S$		3		μs
OUTPUT						
V_{OH}	High output voltage swing	$V_S = \pm 20 \text{ V}, R_L = 10 \text{ k}\Omega$		$+V_S - 97$		mV
		$V_S = \pm 20 \text{ V}, R_L = 2 \text{ k}\Omega$		$+V_S - 257$		
V_{OL}	Low output voltage swing	$V_S = \pm 20 \text{ V}, R_L = 10 \text{ k}\Omega$		$-V_S + 52$		mV
		$V_S = \pm 20 \text{ V}, R_L = 2 \text{ k}\Omega$		$-V_S + 232$		
I_{SC}	Short-circuit current			± 40		mA
POWER SUPPLY						
V_S	Operating supply voltage	$T_A = -40 \text{ to } +125 \text{ }^\circ\text{C}$	4.5		48	V
I_Q	Quiescent current (per amplifier)	$V_S = 5 \text{ V}$		150		μA
		$V_S = 40 \text{ V}$		220		
THERMAL CHARACTERISTICS						
θ_{JA}	Package Thermal Resistance	SOT-23-5		190		$^\circ\text{C/W}$
		MSOP-8		201		
		SOP-8		125		
		TSSOP-14		112		
		DFN-8		65		
		SOP-14		115		

Typical Performance Characteristics

At $T_A = +25\text{ }^\circ\text{C}$, $V_{CM} = V_S / 2$, and $R_L = 10\text{ k}\Omega$ connected to $V_S / 2$, unless otherwise noted.

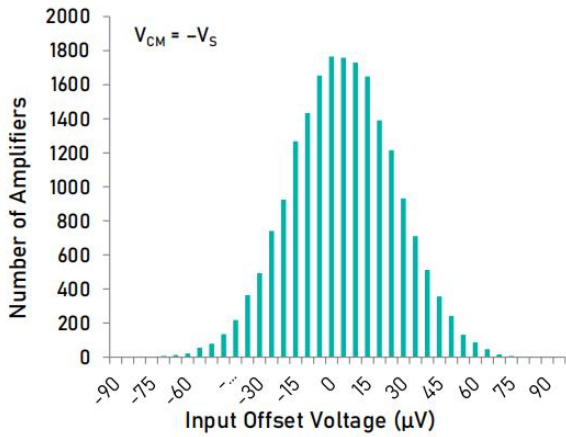

Offset Voltage Production Distribution

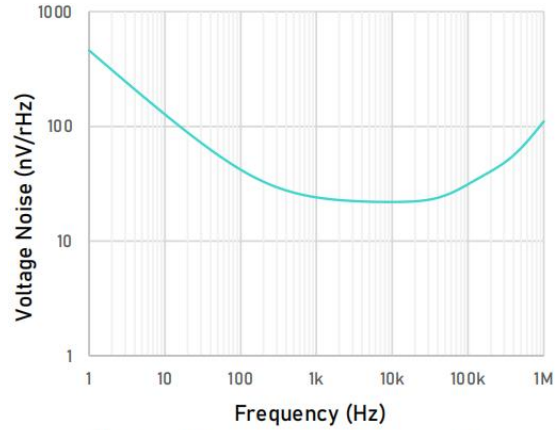

Input Voltage Noise Spectral Density as a function of Frequency

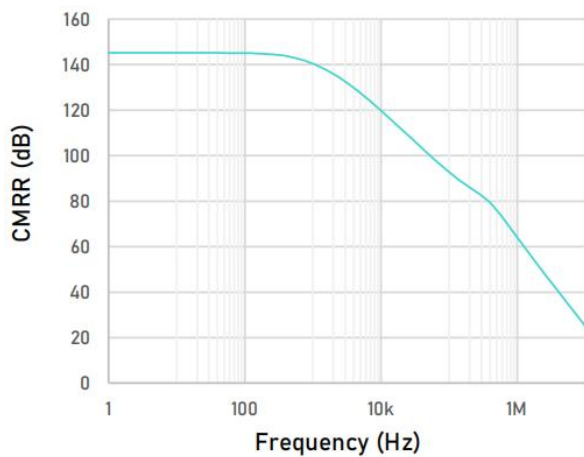

CMRR as a function of Frequency

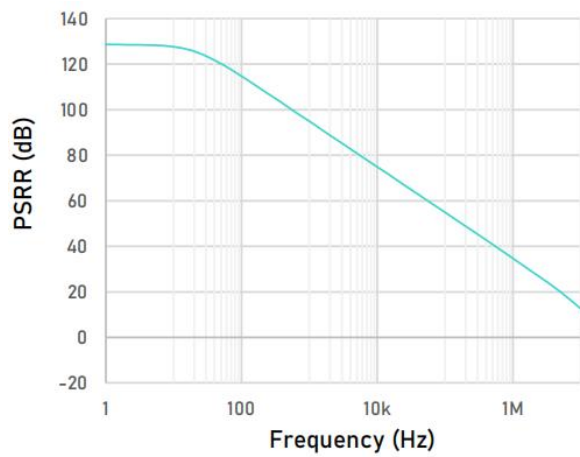

PSRR as a function of Frequency

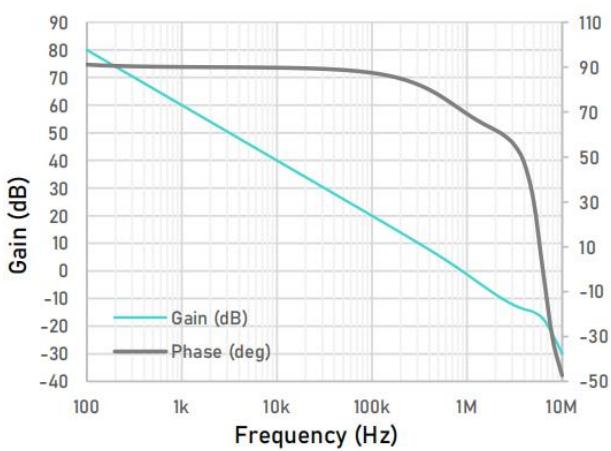

Open-loop Gain and Phase as a function of Frequency

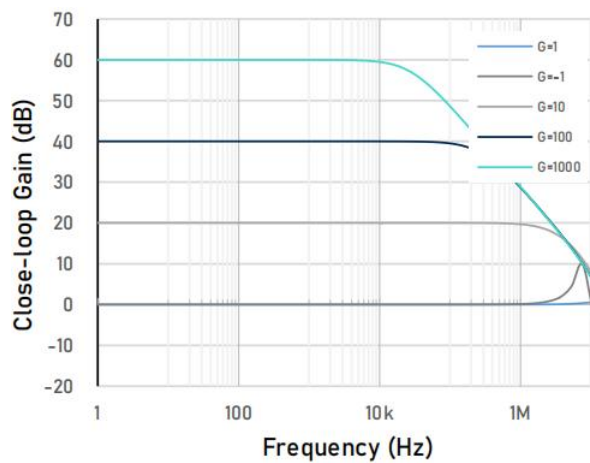

Close-loop Gain as a function of Frequency

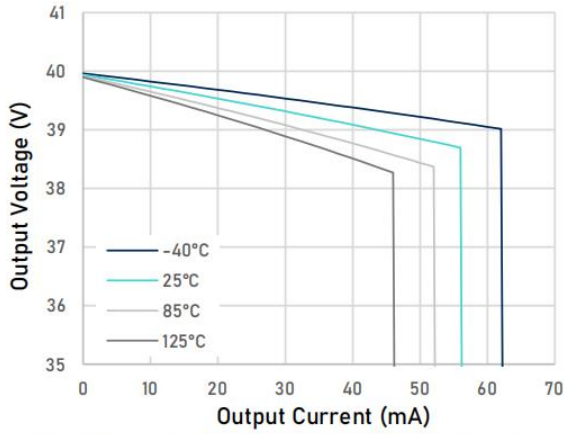

Output Voltage Swing as a function of Output Current (Sourcing, $V_S = 40\text{ V}$)

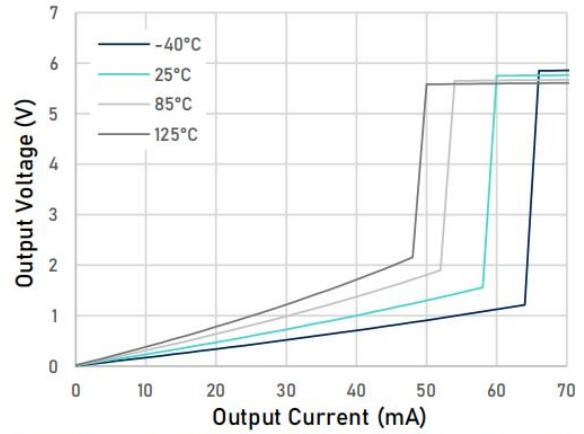

Output Voltage Swing as a function of Output Current (Sinking, $V_S = 40\text{ V}$)

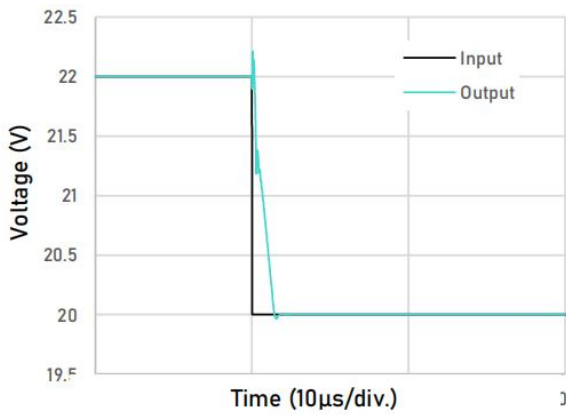

Large-Signal Step Response (Failing)

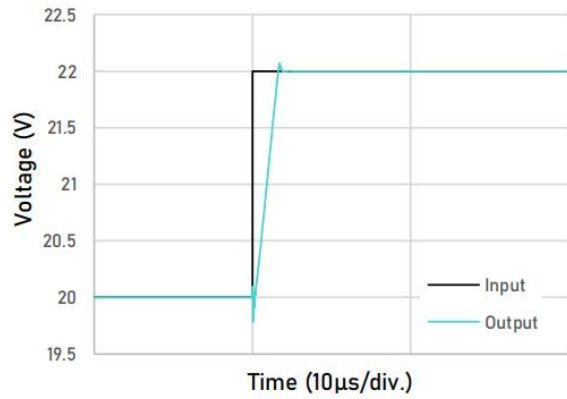

Large-Signal Step Response (Rising)

Physical Dimensions

SOP-8

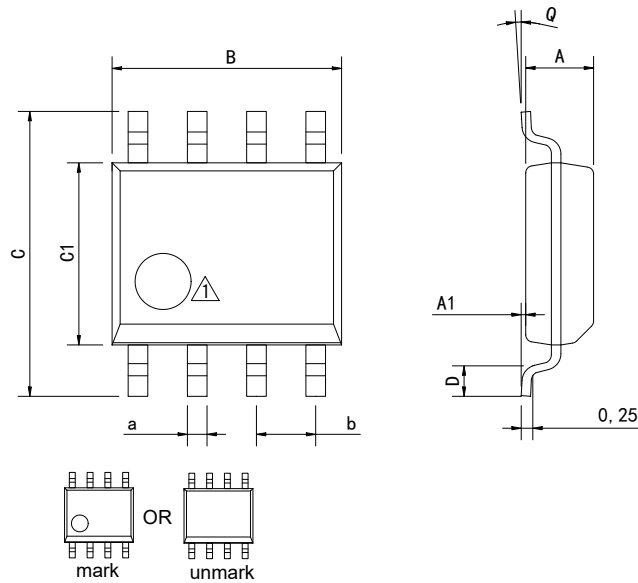

△ Package top mark may be in lower left corner or unmark

Dimensions In Millimeters(SOP-8)									
Symbol:	A	A1	B	C	C1	D	Q	a	b
Min:	1.35	0.05	4.90	5.80	3.80	0.40	0°	0.35	1.27 BSC
Max:	1.55	0.20	5.10	6.20	4.00	0.80	8°	0.45	

SOP-14

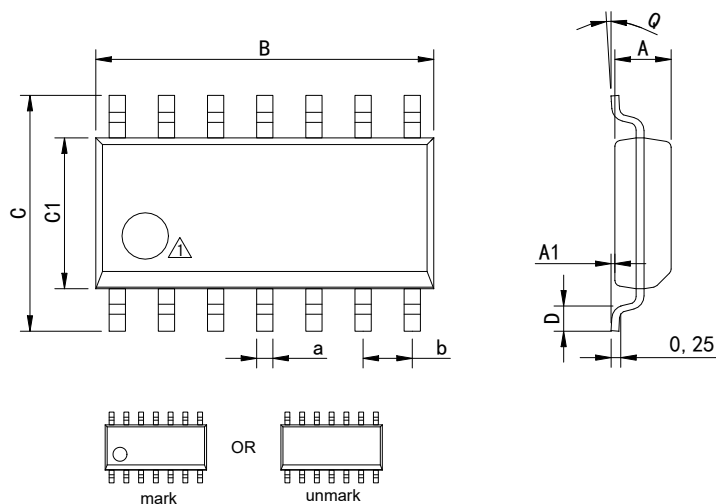

△ Package top mark may be in lower left corner or unmark

Dimensions In Millimeters(SOP-14)									
Symbol:	A	A1	B	C	C1	D	Q	a	b
Min:	1.35	0.05	8.55	5.80	3.80	0.40	0°	0.35	1.27 BSC
Max:	1.55	0.20	8.75	6.20	4.00	0.80	8°	0.45	

Physical Dimensions

MSOP-8

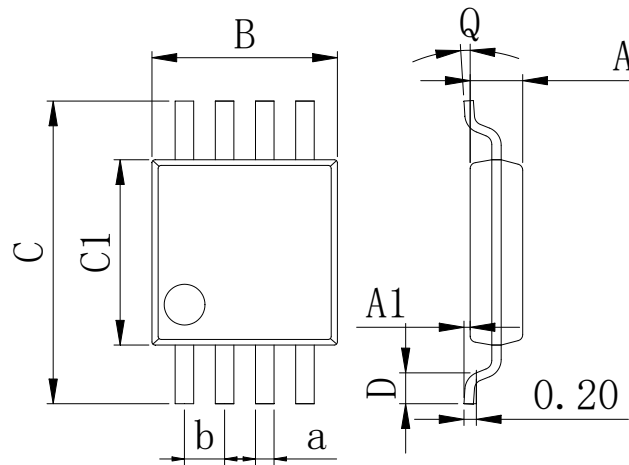

Dimensions In Millimeters(MSOP-8)									
Symbol:	A	A1	B	C	C1	D	Q	a	b
Min:	0.80	0.05	2.90	4.75	2.90	0.35	0°	0.25	0.65 BSC
Max:	0.90	0.20	3.10	5.05	3.10	0.75	8°	0.35	

DFN-8 3*3

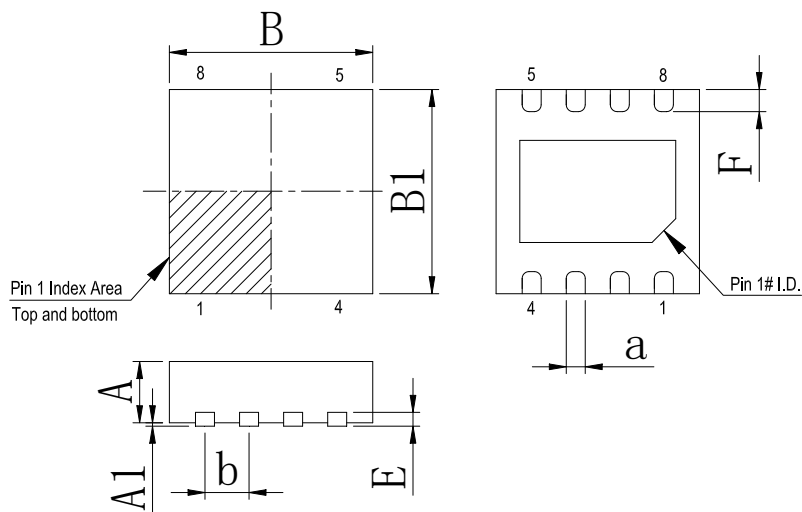

Dimensions In Millimeters(DFN-8 3*3)								
Symbol:	A	A1	B	B1	E	F	a	b
Min:	0.85	0.00	2.90	2.90	0.20	0.30	0.20	0.65 BSC
Max:	0.95	0.05	3.10	3.10	0.25	0.50	0.34	

Physical Dimensions

TSSOP-14

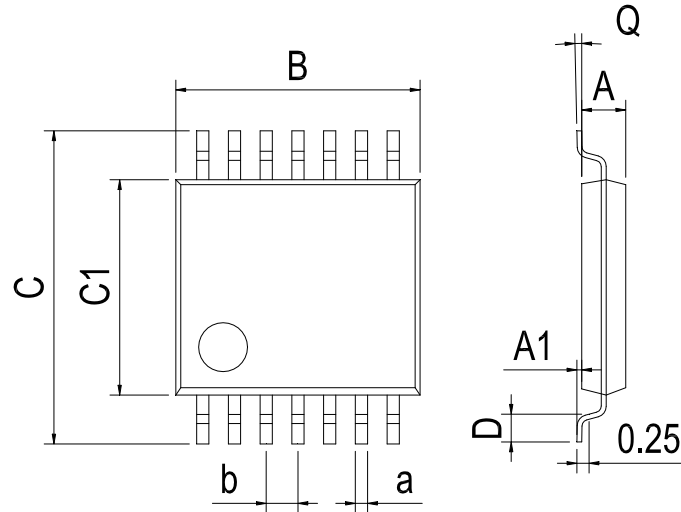

Dimensions In Millimeters(TSSOP-14)									
Symbol:	A	A1	B	C	C1	D	Q	a	b
Min:	0.85	0.05	4.90	6.20	4.30	0.40	0°	0.20	0.65 BSC
Max:	0.95	0.20	5.10	6.60	4.50	0.80	8°	0.25	

SOT-23-5

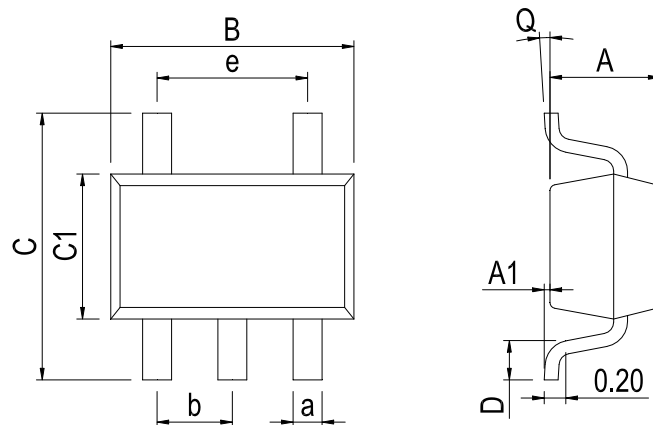

Dimensions In Millimeters(SOT-23-5)										
Symbol:	A	A1	B	C	C1	D	Q	a	b	e
Min:	1.00	0.00	2.82	2.65	1.50	0.30	0°	0.30	0.95 BSC	1.90 BSC
Max:	1.15	0.15	3.02	2.95	1.70	0.60	8°	0.50		

Physical Dimensions

DIP-8

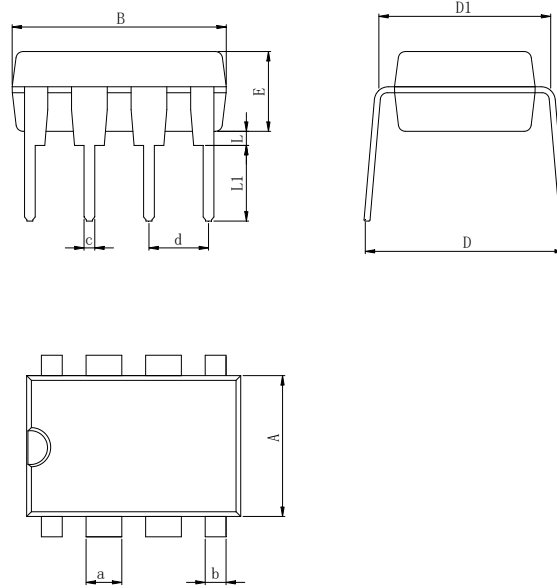

Dimensions In Millimeters(DIP-8)											
Symbol:	A	B	D	D1	E	L	L1	a	b	c	d
Min:	6.10	9.00	8.10	7.42	3.10	0.50	3.00	1.50	0.85	0.40	2.54 BSC
Max:	6.68	9.50	10.9	7.82	3.55	0.70	3.60	1.55	0.90	0.50	

Revision History

REVISION NUMBER	DATE	REVISION	PAGE
V1.0	2018-11	New	1-10
V1.1	2025-6	Document Reformatting	1-13

IMPORTANT STATEMENT:

Huaguan Semiconductor reserves the right to change products and services offered without prior notice. Customers should obtain the latest relevant information before placing orders and verify that such information is current and complete. Huaguan Semiconductor assumes no responsibility or liability for altered documents.

Customers are responsible for complying with safety standards and implementing safety measures when using Huaguan Semiconductor products in system design and end-product manufacturing. You assume full responsibility for: selecting the appropriate Huaguan Semiconductor products for your application; designing, validating, and testing your application; and ensuring that your application complies with applicable standards and all other safety, security, or other requirements. This is to prevent potential risks that may lead to personal injury or property damage.

Huaguan Semiconductor products are not approved for use in life support, military, aerospace, or other high-risk applications. Huaguan products are neither intended nor warranted for use in such systems or equipment. Any failure or malfunction may lead to personal injury or severe property damage. Such applications are deemed "Unsafe Use." Unsafe Use includes, but is not limited to: surgical and medical equipment, nuclear energy control equipment, aircraft or spacecraft instruments, control or operation of vehicle power, braking, or safety systems, traffic signal instruments, all types of safety devices, and any other applications intended to support or sustain life. Huaguan Semiconductor shall not be liable for consequences resulting from Unsafe Use in these fields. Users must independently evaluate and assume all risks. Any issues, liabilities, or losses arising from the use of products beyond their approved applications shall be solely borne by the user. Users may not claim any compensation from Huaguan Semiconductor based on these terms. If any third party claims against Huaguan Semiconductor due to such Unsafe Use, the user shall compensate Huaguan Semiconductor for all resulting damages and liabilities.

Huaguan Semiconductor provides technical and reliability data (including datasheets), design resources (including reference designs), application or other design advice, web tools, safety information, and other resources for its semiconductor products. However, no guarantee is made that these resources are free from defects, and no express or implied warranties are provided. The use of testing and other quality control techniques is limited to Huaguan Semiconductor's quality assurance scope. Not all parameters of each device are tested.

Huaguan Semiconductor's documentation authorizes you to use these resources only for developing applications related to the products described herein. You are not granted rights to any other intellectual property of Huaguan Semiconductor or any third party. Any other reproduction or display of these resources is strictly prohibited. You shall fully indemnify Huaguan Semiconductor and its agents against any claims, damages, costs, losses, and liabilities arising from your use of these resources. Huaguan Semiconductor shall not be held responsible.