

REV		MARK	修改摘要	签名	日期
NO			REVISION DESCRIPTION	SIGNATURE	DATE
			NEW DWG		2016-03-12

NOTES:

- MATERIAL:
  - INSERTMOLDING: LCP, COLOR:BLACK,UL94-V0.
  - CONTACT: C2680(T=0.20mm);  
GOLD FLASH ON CONTACT AREA,  
100u" Min. Tin PLATED ON SOLDER TAILS.  
50u" Min. NICKEL PLATED OVERALL.
  - SHELL: SPCC,(T=0.40mm);  
100u" Min. NICKEL PLATED OVERALL.  
120u" Min. COPPER BOTTOM PLATED OVERALL.
- ELECTRICAL CHARACTERISTICS:
  - CURRENT RATING: 0.5A
  - CONTACT RESISTANCE: 30mΩ MAX.
  - INSULATION RESISTANCE: 100MΩ MIN.
  - DIELECTRIC WITHSTAND VOLTAGE: AC 500V/MINUTE.
  - OPERATING TEMPERATURE RANGE: -25°C~+85°C
- MECHANICAL CHARACTERISTICS:
  - INSERTION FORCE: 4.5Kgf MAX.
  - EXTRACTION FORCE: 1.0Kgf MIN.,4.0Kgf MAX.
- DURABILITY: 5000 CYCLES.
- SALT FOG TEST:24H.

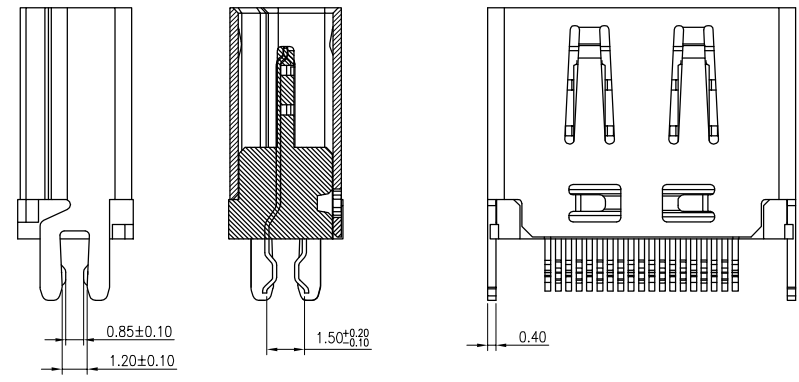

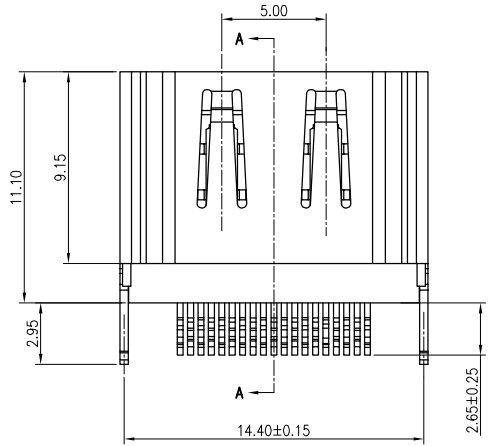
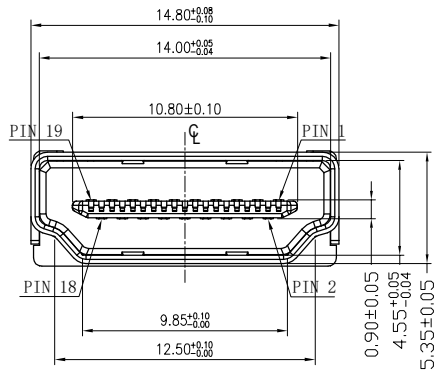
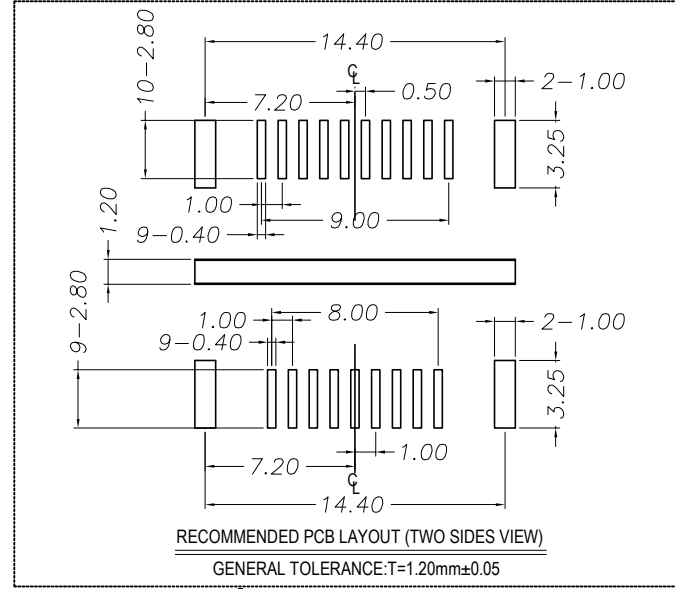

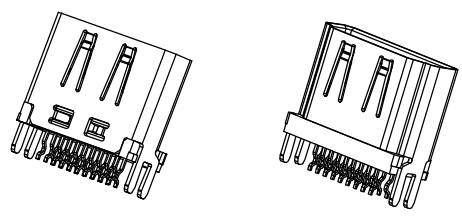
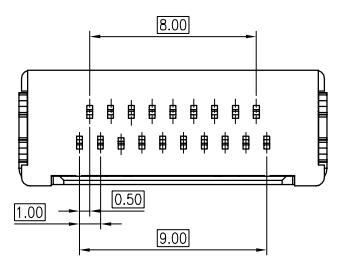
PIN	Signal Assignment	PIN	Signal Assignment
1	TMDS Data2+	2	TMDS Data2 Shield
3	TMDS Data2-	4	TMDS Data1+
5	TMDS Data1 Shield	6	TMDS Data1-
7	TMDS Data0+	8	TMDS Data0 Shield
9	TMDS Data0-	10	TMDS Clock+
11	TMDS Clock Shield	12	TMDS Clock-
13	CEC	14	Utility
15	SCL	16	SDA
17	DDC/CEC Ground	18	+5V Power
19	Hot Plug Detect		





深圳市华德共创科技有限公司  
Shenzhen Huade co-create Technology Co., LTD  
电话: 0755-27111216 传真: 0755-29940187

-TOLERANCES- UNLESS OTHERWISE SPECIFIED 公差参数表		 	TITLE: 产品名称: HDMI A TYPE母座夹板1.2MM				
X.X	±0.30	X.X*	±3°	APPD: 核准:		PART NO: 产品编号: HDMI-DB-128PB	
X.XX	±0.20	X.XX*	±2°	CHECK: 校对: 王建业	DATE	SCALE	UNIT
X.XXX	±0.10	X.XXX*	±1°	DRAW: 绘图: 黄艳兰	2016-03-12	1:1	mm
					CODE NUMBER		A001

修订	标记	修改摘要	签名	日期
REV	MARK	REVISION DESCRIPTION	SIGNATURE	DATE
AO		NEW DWG		2016-03-12

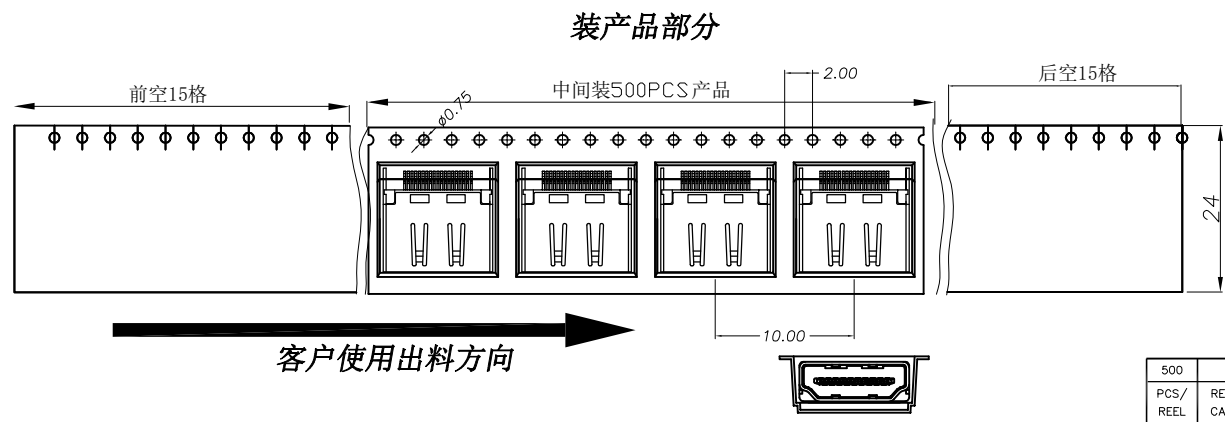
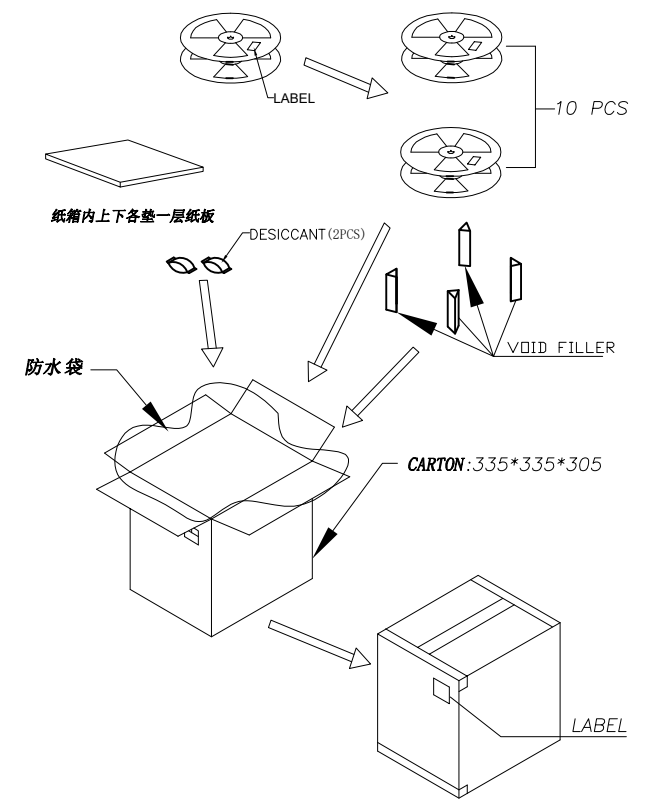
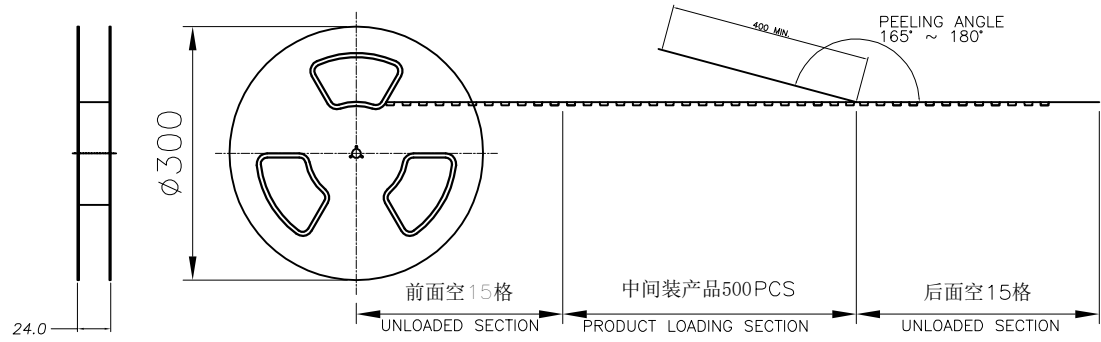

500	10	5000 PCS	--KG	--KG	1.75g
PCS/ REEL	REELS/ CARTON	QUANTITY	GROSS WEIGHT	NET WEIGHT	SINGLE WEIGHT

- NOTE:
- MATERIAL:  
 BOX: FIBREBOARD, CORRUGATED, DOUBLE WALL  
 TAPE: POLYSTYRENES, HEAT-RESISTANT TEMPERATURE: 120°C, TRANSPARENT COLOR.  
 REEL: POLYSTYRENES, HEAT-RESISTANT TEMPERATURE: 70°C, BLUE COLOR.  
 BAG: POLYETHYLENE, HEAT-RESISTANT TEMPERATURE: 100°C.
  - PEELING STRENGTH: 0.1 ~ 1.3 N (10 ~ 130 GRAMS)
  - PEELING SPEED: 300 mm/min.

		深圳市华德共创科技有限公司 Shenzhen Huade co-create Technology Co.,LTD 电话: 0755-27111216 传真: 0755-29940187			
		TITLE: HDMI A TYPE母座夹板1.2MM 产品名称: HDMI A TYPE母座夹板1.2MM			
-TOLERANCES- UNLESS OTHERWISE SPECIFIED 公差参数表				PART NO: HDMI-DB-128PB 产品编号:	
X.X	±0.30	X.X*	±3°	APPD: 核准:	
X.XX	±0.20	X.XX*	±2°	CHECK: 校对: 王建业	DATE SCALE UNIT CODE NUMBER
X.XXX	±0.10	X.XXX*	±1°	DRAW: 绘图: 黄艳兰	2016-03-12 1:1 mm A001