

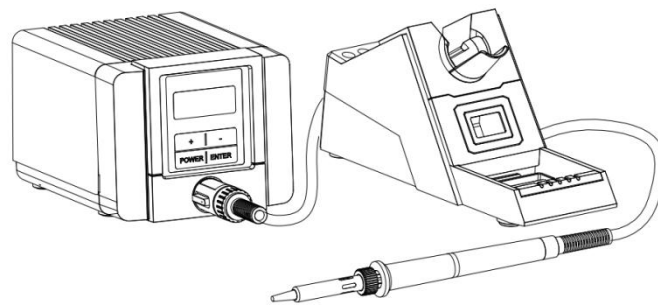

QUICK TS1100 Soldering Station

Instruction Manual



Thank you for purchasing our products. Please keep the instruction manual properly for future reference.

Contents

1. Safety Instructions.....	1
2. Overview.....	2
3. Product Characteristics.....	2
4. Product Specifications.....	3
5. Product Specifications.....	4
5.1. Dimensions.....	4
5.2. Part Descriptions.....	5
6. Use of Holder and Sponge.....	5
7. Connection.....	5
8. Turn On/Off.....	5
9. Menu Settings.....	6
10. Temperature Calibration.....	7
11. Maintenance of Tips.....	7
12. Selection of Tips.....	8
13. Guide for Replacing Heater.....	9
13.1. Steps for Removing Heater.....	9
13.2. Steps for Replacing Heater.....	9
14. Troubleshooting.....	10
15. List of Tips.....	11

1. Safety Instructions



CAUTION

- During the installation and use of this product, all electrical safety regulations of the country and regions must be strictly observed.
- The power supply must be disconnected when disassembling the product. Do not operate with power on.
- If the product does not work properly, please contact the supplier or our company, and do not disassemble or change the product in any way. We are not responsible for any problems caused by unauthorized maintenance or modification.



WARNING

- The product should be used away from places where there is magnetic interference.
- Don't install the product in a place where the surface is easy to shake or be impacted, as it may damage the product.
- Don't install the product in places where it may be exposed to rain or moisture.
- Don't use in flammable and explosive environments.
- After using the soldering station, the tip temperature will be quite high, which is easy to burn operators and may cause dangerous accidents.
- Power supply should be turned off during breaks or after work.
- Don't knock workbench with the soldering pencil to remove residual flux, which may seriously damage the soldering pencil.
- When the soldering pencil is not in use, please turn off the power to prolong its life.
- Please unplug the power cord when the product is not used for a long time.

2. Overview

This product is an intelligent lead-free soldering station. The soldering station adopts LCD liquid crystal display and touch buttons, which is more comfortable to use. Digital calibration mode, fast and convenient. Accurate and sensitive temperature sensing, fast heating and temperature recovery, ideal for lead-free soldering

3. Product Characteristics

- Password lock function, protecting technological parameter.
- Temperature warning function, Celsius and Fahrenheit can exchange.
- Hand shake is very light and handy, can distinguish hand shake.
- LCD, heater can be pull out easy, maintenance is simple.
- Anti-static device, ESD measuring ability.
- Has dormancy function, protects the welding tip and prolongs the life.

4. Product Specifications

Model	TS1100
Display	LCD
Power consumption	90W
Voltage	220VAC
Temperature range	200°C~450°C/392F~842F
Ambient temperature	40°C
Tip to ground resistance	<2mV
Tip to ground potential	<2Ω
Dimensions (W×H×D)	113*150*92 mm
Weight	About 2.3Kg

5. Product Specifications

5. 1. Dimensions

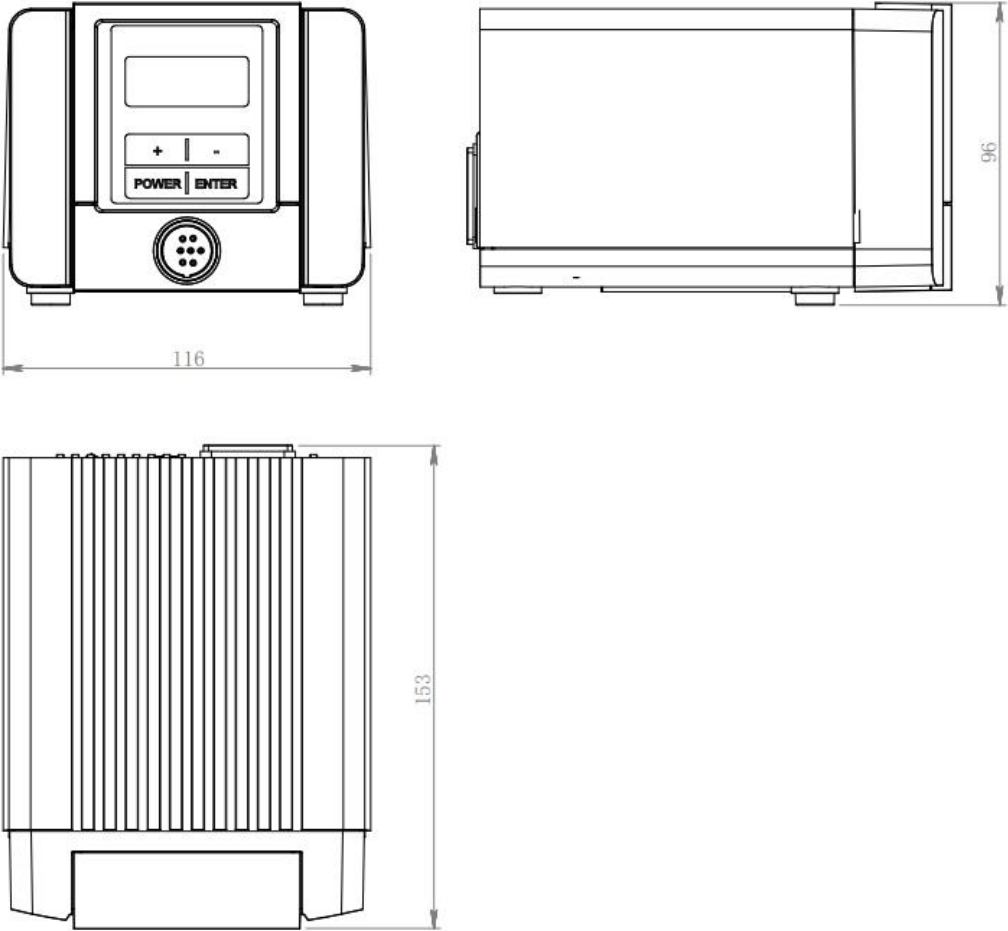

Unit: mm

5. 2. Part Descriptions

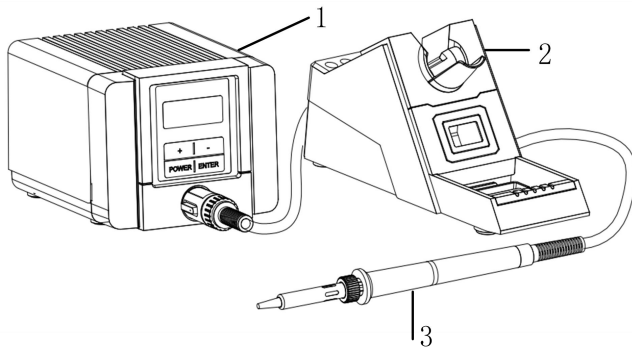

NO.	Part Descriptions
1	Main unit
2	Holder
3	Soldering pencil

6. Use of Holder and Sponge

- 1) Wet the cleaning sponge and then squeeze it dry.
- 2) Place the sponge into the groove of the holder base.
- 3) In the process of use, if the sponge becomes dry, please add water appropriately.

7. Connection

- 1) Insert the seven-core plug at the other end of the soldering pencil into the seven-core socket on the main unit (pay attention to the insertion position of the plug), and place the soldering pencil in the holder.
- 2) Insert the power plug of the soldering station into the power socket.
- 3) Insert one end of the grounding core into the grounding jack of the soldering station, and connect one end to anti-static ground.

8. Turn On/Off

Switch on/off, which can be divided into hard switch and soft switch.

- 1) Hard switch on / off: The power switch on the back of the main unit can realize hard switching;
- 2) Soft switch on / off: After the power switch is powered on, it can be turned on or off by long pressing the POWER key for 2 seconds.

9. Menu Settings

press ENTER key about 2s , enter password interface, press +/- and choose the number, press ENTER to input the next number (initial password is 000). Only Input the right password can pass into menu interface. If input error password tow times, soldering station will be locked, input the right password or restart the unit could be unlocked.

Menu setting include 6 items:

1)Back to main interface:use the +/- button to choose the menu-1- in menu choose interface, press ENTER back to main interface.



2)Temperature unit change:Press “+” key, Selected the menu-2-, press “ENTER” affirm, and then press “+” key or “-“ key select temperature unit, °C is degree centigrade, °F is Fahrenheit, and then press “ENTER” affirm. as following



3)ESD function:Press “+” key, select the menu-3-, press “ENTER” affirm. Press “+” key or “-“ key select ON/OFF , and then press “ENTER” affirm.



4)Sleep time:Press “+” key ,select the menu-4-, press “ENTER” affirm.Then press “+” or “-”key to change the off time, press “ENTER” affirm. The range of off time is 1-30min. Sleep temperature is 200°C.



5)Channel temperature setting:Press “+” key, select the menu-5-, press “ENTER” affirm. Press “+” key or “-“ key select CH1-CH3 .

If you Choose CH1, pressing ENTER could edit CH1 temperature, press +/- to edit temperature, press ENTER save. (factory setting : CH1---320°C, CH2---350°C, CH3---380°C)



6)Resetting password: Press “+” key, ,select the menu-4-, press “ENTER” affirm. Press +/- to select number 0~9, press ENTER to save. Must input new password twice ,then it will show  .





10. Temperature Calibration

The soldering iron should be calibrated after changing the nozzle or heat element.

Calibrate by using thermometer:

- 1)Set the unit's temperature to a certain value.
- 2)When the temperature stabilizes, measure the tip's temperature with thermometer and write down the reading.
- 3)Press + and ENTER button for a while, enter into calibration mode.



3)Press +/- to input the measured value. If calibration success it will show  . If fail it will show  .

11. Maintenance of Tips

- 1)When the new tip is used for the first time, add tin to protect it when the temperature is 250 ~ 280 °C.
- 2) Select the appropriate tip size according to the size of soldering joints.
- 3) In order to prevent the oxidation of tips, a layer of soldering tin should be plated before placing it into the holder.

4) In order to avoid rapid cooling of tips, the cleaning sponge should not be wet with too much water. But using cleaning sponge that is not wet will damage the tips and lead to failure of tinning the tips.

5) When the tip is oxidized due to improper use, do not clean the surface coating by grinding but use metal filament or resurrection ointment to clean it at 250 ~ 280 °C.

6) When soldering, do not apply gravity to tips and avoid adding tin to the same place to operate.

7) Try to solder at low temperature, and the temperature is usually controlled at 320 ~ 380°C. If it is necessary to solder at high temperature, please analyze the adaptability of soldering station and tips before soldering.

12. Selection of Tips

1) It is very important to correctly select the size and shape of tips. A suitable tip can improve the efficiency and increase the durability.

2) The size of tips is directly related to the heat capacity. For continuous soldering, the larger the tip, the less the temperature drop. In addition, because the heat capacity of the large tips is higher and relatively low temperature can be used during soldering, the tips are not easy to oxidize and the service life is relatively prolonged.

3) Generally speaking, the selection of tip size is based on the standard that it does not affect adjacent components. Selecting the geometric dimension that can fully contact with the soldering joint can improve the soldering efficiency.

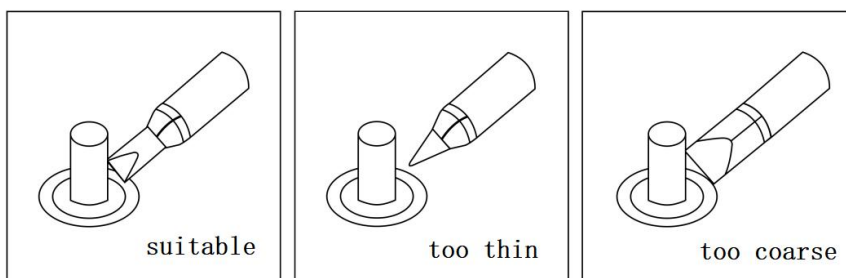

13. Guide for Replacing Heater

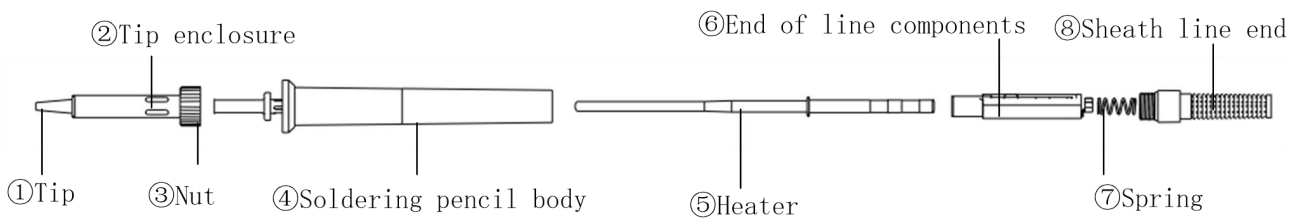

13. 1. Steps for Removing Heater

- 1) Unscrew ⑧ Sheath line end.
- 2) Pull out the ⑥ End of line components from the ④ soldering pencil body.
- 3) Pull out the ⑤ Heater from the ⑥ End of line components.

Note: all operation steps are carried out when the power is cut off and the soldering pencil is cooled.

13. 2. Steps for Replacing Heater

- 1) Insert the ⑤ Heater into the ④ soldering pencil body, turn the heating core and pull it down when installing, until the bayonet is stuck and the heater cannot be rotated.

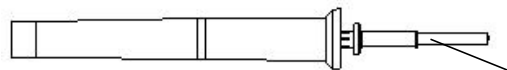

When installing, turn the heater here

- 2) Insert the ⑥ End of line components into the ④ Soldering pencil body, and plug it to the end.
- 3) Insert ⑦ spring into ④ Soldering pencil body.
- 4) Screw the ⑧ Sheath line end onto the main body of the ④ Soldering pencil body. After screwing, press the bottom of the heater with your hand. If it can rebound upwards, it means the installation is in place.

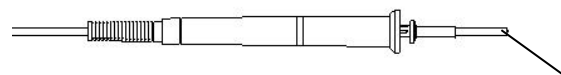

Hold the bottom of the heater to see if it rebounds

5) Put the③Nut on the⑤Heater.

6) Put on the①Tip and screw on the②Tip enclosure.

7) After replacing the heater, the following measurements are recommended.

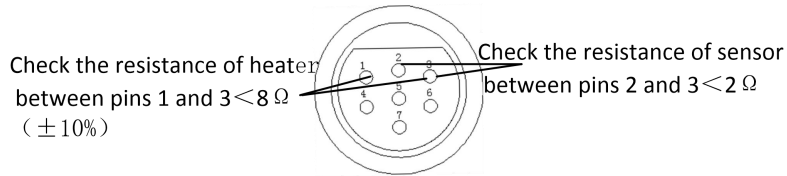

8) After replacing the heater, it is recommended to recalibrate the temperature (refer to the temperature calibration steps).

14. Troubleshooting

NO.	Error display	Error description
1	H-1	Heater short circuit
2	H-2	Heater open circuit
3	H-3	circuit error
4	S-E	Sensor error
5	ERR	The handle model is wrong, or the handle is not inserted

15. List of Tips

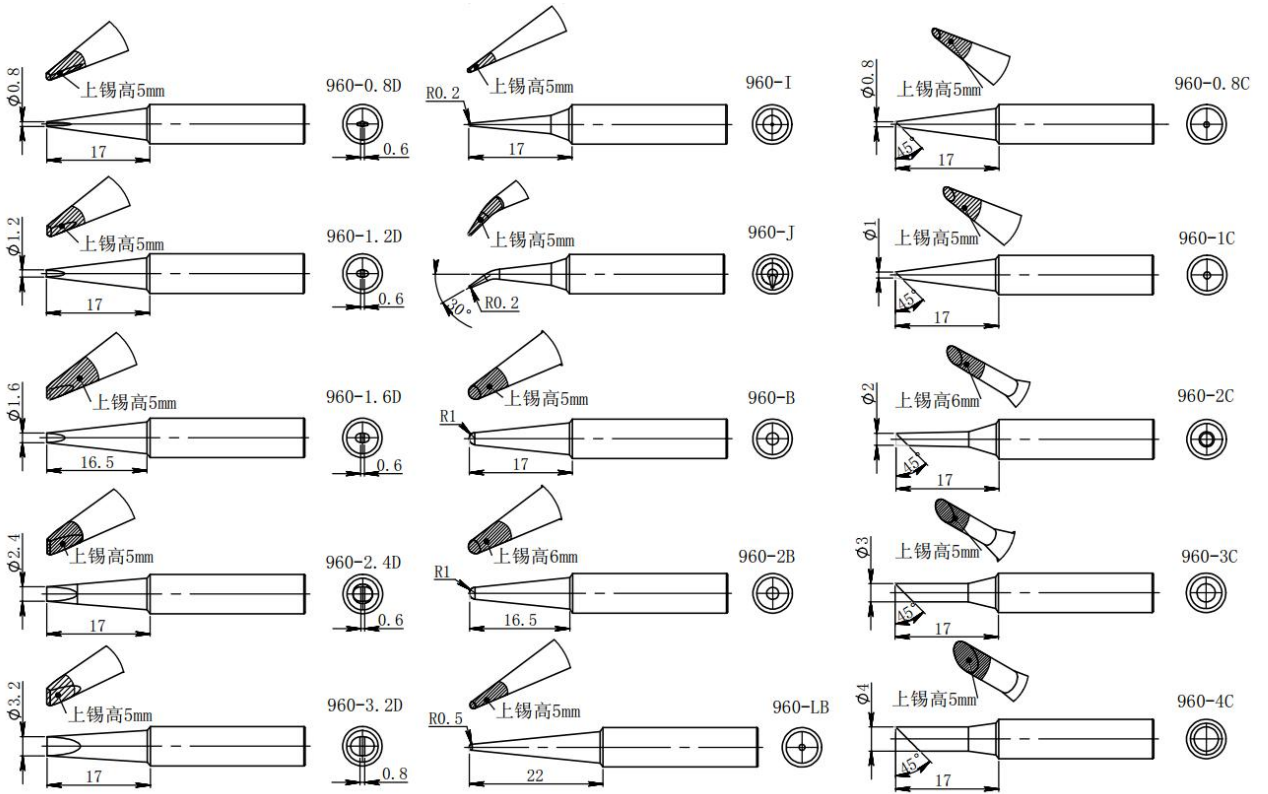

Warranty Card

●The warranty period of this product is calculated from the date of purchase. During the warranty period, if the product breaks down during normal use, show the original warranty card and enjoy free service in the authorized repair company (or our company). Please keep the purchase certificate and this warranty card and show it before maintenance.

●During the warranty period, the following repairs need to be paid:

- a. Unable to offer valid warranty card or certificate;
- b. The purchase date, sales company and other items are not completely filled in or the warranty card is altered;
- c. Damage caused by failure to follow the use methods and precautions in the manual;
- d. Damage caused by disassembly, repair and modification of products without authorization of the manufacturer;
- e. Replacement of vulnerable and consumable parts.

●All items of the warranty card shall be completely filled in by the agent or user to obtain a 12-month warranty period.

●Please keep this warranty card properly. It will not be re-offered after.

QUICK INTELLIGENT EQUIPMENT CO., LTD.

ADD: NO.11, FengXiang Road, Wujin
High-Tech Industrial Development Zone,
Jiangsu, China

TEL: 86-519-86225678

FAX: 86-519-86558599

POSTCODE: 213167

WEBSITE: www.quick-global.com

Warranty Card

Type: _____

Model No.: _____

Serial No.: _____

Delivery Date: _____

Warranty File Card

Type: _____

Model No.: _____

Serial No.: _____

Delivery Date: _____

Address : _____

Postcode: _____

Telephone: _____

Contact Person: _____

QUICK INTELLIGENT EQUIPMENT CO., LTD.

ADD: NO.11, FengXiang Road, Wujin High-Tech Industrial
Development Zone, Jiangsu, China

TEL: 86-519-86225678

FAX: 86-519-86558599

POSTCODE: 213167

WEBSITE: www.quick-global.com

