

FEATURES

- * For surface mount application
- * Built-in strain relief
- * Excellent clamping capability
- * Low profile package
- * Fast response time: Typically less than 1.0ps from 0 volt to BV min.
- * Typical I_R less than 1 A above 10V
- * High temperature soldering guaranteed: 260°C / 10 seconds at terminals



VOLTAGE RANGE

5.0 to 440 Volts
600 Watts Peak Power

MECHANICAL DATA

- * Case: Molded plastic
- * Epoxy: UL 94V-0 rate flame retardant
- * Lead: Solderable per MIL-STD-202, method 208 guaranteed
- * Polarity: Color band denotes cathode end except Bidirectional
- * Mounting position: Any
- * Weight: 0.063 grams



- "GK" represents the brand name
- "XXX" represents the periodic code
- "YY" represents the product type marking

MAXIMUM RATINGS AND ELECTRICAL CHARACTERISTICS

Rating 25°C ambient temperature unless otherwise specified.
Single phase half wave, 60Hz, resistive or inductive load.
For capacitive load, derate current by 20%.

RATINGS	SYMBOL	VALUE	UNITS
Peak Power Dissipation at $T_A=25^\circ\text{C}$, $T_P=1\text{ms}$ (NOTE 1)	P_{PK}	Minimum 600	Watts
Peak Forward Surge Current at 8.3ms Single Half Sine-Wave superimposed on rated load (JEDEC method) (NOTE 3)	I_{FSM}	80	Amps
Maximum Instantaneous Forward Voltage at 25.0A for Unidirectional only	V_F	3.5	Volts
Operating and Storage Temperature Range	T_J, T_{STG}	-55 to +150	°C

NOTES:

1. Non-repetitive current pulse per Fig. 3 and derated above $T_A=25^\circ\text{C}$ per Fig. 2.
2. Mounted on Copper Pad area of 5.0mm^2 (.013mm Thick) to each terminal.
3. 8.3ms single half sine-wave, duty cycle = 4 pulses per minute maximum.

DEVICES FOR BIDIRECTIONAL APPLICATIONS

- 1. For bi-directional use C suffix for Types .
- 2. Electrical characteristics apply in both directions.

RATING AND CHARACTERISTIC CURVES

FIG.1-PEAK PULSE POWER DERATING CURVE

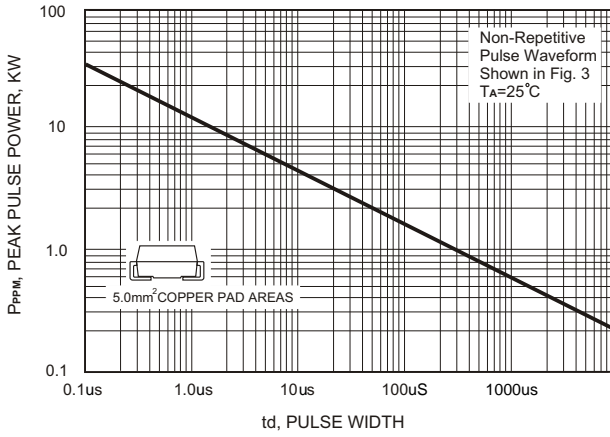

FIG.2-PULSE DERATING CURVE

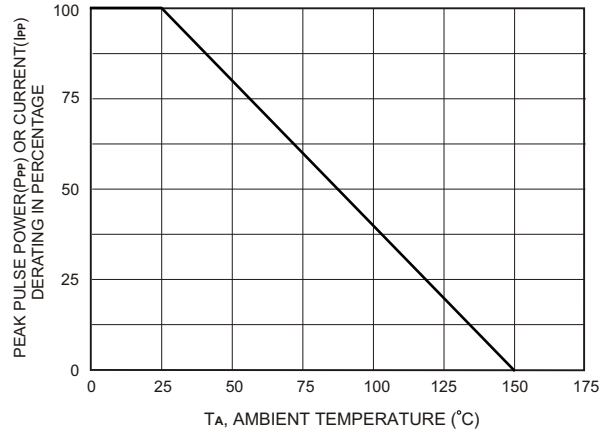

FIG.3-PULSE WAVE FORM

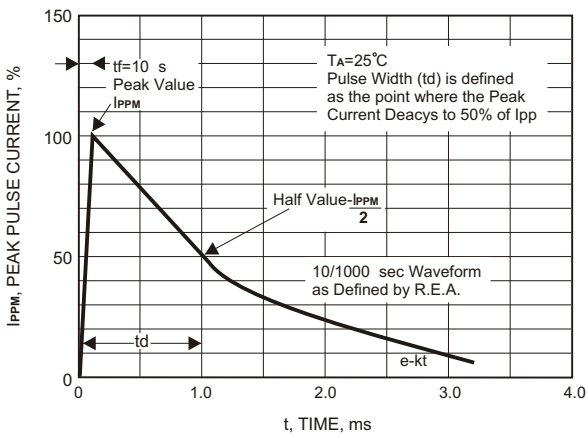

FIG.4 MAXIMUM NON REPETITIVE PEAK FORWARD SURGE CURRENT

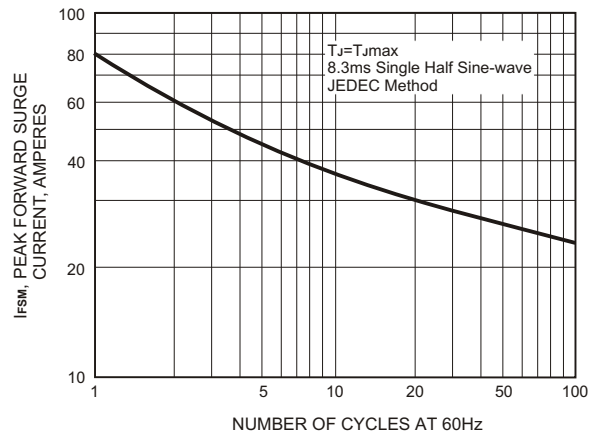
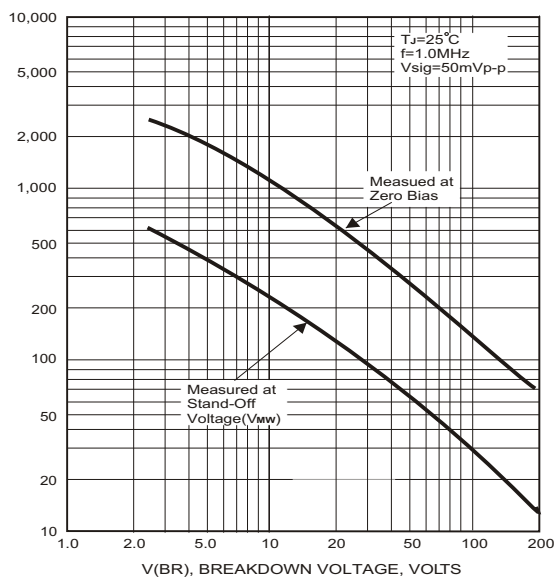

FIG.5-TYPICAL JUNCTION CAPACITANCE



PART NUMBER ADD C FOR BI- DIRECTIONAL	REVERSE STAND-OFF VOLTAGE VRWM (V)	BREAKDOWN VOLTAGE VBR (V)		TEST CURRENT IT (mA)	MAXIMUM CLAMPING VOLTAGE @Ipp Vc (V)	PEAK PULSE CURRENT Ipp (A)	REVERSE LEAKAGE @ VRWM IR(μA)	MARKING CODE	
		MIN. @IT	MAX. @IT					UNI	BI
See Note 1									
SMA6J5.0(C)A	5.0	6.40	7.25	10	9.2	43.5	800	6AE	6WE
SMA6J6.0(C)A	6.0	6.67	7.67	10	10.3	38.8	800	6AG	6WG
SMA6J6.5(C)A	6.5	7.22	8.30	10	11.2	35.7	500	6AK	6WK
SMA6J7.0(C)A	7.0	7.78	8.95	10	12.0	33.3	200	6AM	6WM
SMA6J7.5(C)A	7.5	8.33	9.58	1	12.9	31.0	100	6AP	6WP
SMA6J8.0(C)A	8.0	8.89	10.23	1	13.6	29.4	50	6AR	6WR
SMA6J8.5(C)A	8.5	9.44	10.82	1	14.4	27.7	10	6AT	6WT
SMA6J9.0(C)A	9.0	10.0	11.50	1	15.4	26.0	5	6AV	6WV
SMA6J10(C)A	10	11.1	12.80	1	17.0	23.5	5	6AX	6WX
SMA6J11(C)A	11	12.2	14.00	1	18.2	22.0	5	6AZ	6WZ
SMA6J12(C)A	12	13.3	15.30	1	19.9	20.1	5	6BE	6XE
SMA6J13(C)A	13	14.4	16.50	1	21.5	18.6	5	6BG	6XG
SMA6J14(C)A	14	15.6	17.90	1	23.2	17.2	5	6BK	6XK
SMA6J15(C)A	15	16.7	19.20	1	24.4	16.4	5	6BM	6XM
SMA6J16(C)A	16	17.8	20.50	1	26.0	15.3	5	6BP	6XP
SMA6J17(C)A	17	18.9	21.70	1	27.6	14.5	5	6BR	6XR
SMA6J18(C)A	18	20.0	23.30	1	29.2	13.7	5	6BT	6XT
SMA6J20(C)A	20	22.2	25.50	1	32.4	12.3	5	6BV	6XV
SMA6J22(C)A	22	24.4	28.00	1	35.5	11.2	5	6BX	6XX
SMA6J24(C)A	24	26.7	30.70	1	38.9	10.3	5	6BZ	6XZ
SMA6J26(C)A	26	28.9	33.20	1	42.1	9.5	5	6CE	6YE
SMA6J28(C)A	28	31.1	35.80	1	45.4	8.8	5	6CG	6YG
SMA6J30(C)A	30	33.3	38.30	1	48.4	8.3	5	6CK	6YK
SMA6J33(C)A	33	36.7	42.20	1	53.3	7.5	5	6CM	6YM
SMA6J36(C)A	36	40.0	46.00	1	58.1	6.9	5	6CP	6YP
SMA6J40(C)A	40	44.4	51.10	1	64.5	6.2	5	6CR	6YR
SMA6J43(C)A	43	47.8	54.90	1	69.4	5.7	5	6CT	6YT
SMA6J45(C)A	45	50.0	57.50	1	72.7	5.5	5	6CV	6YV
SMA6J48(C)A	48	53.3	61.30	1	77.4	5.2	5	6CX	6YX
SMA6J51(C)A	51	56.7	65.20	1	82.4	4.9	5	6CZ	6YZ
SMA6J54(C)A	54	60.0	69.00	1	87.1	4.6	5	6RE	6ZE
SMA6J58(C)A	58	64.4	74.10	1	93.6	4.3	5	6RG	6ZG

PART NUMBER ADD C FOR BI- DIRECTIONAL	REVERSE STAND-OFF VOLTAGE VRWM (V)	BREAKDOWN VOLTAGE VBR (V)		TEST CURRENT IT (mA)	MAXIMUM CLAMPING VOLTAGE @Ipp Vc (V)	PEAK PULSE CURRENT Ipp (A)	REVERSE LEAKAGE @ VRWM IR(μA)	MARKING CODE	
		MIN. @IT	MAX. @IT					UNI	BI
SMA6J60(C)A	60	66.7	76.7	1	96.8	4.1	5	6RK	6ZK
SMA6J64(C)A	64	71.1	81.8	1	103	3.9	5	6RM	6ZM
SMA6J70(C)A	70	77.8	89.5	1	113	3.5	5	6RP	6ZP
SMA6J75(C)A	75	83.3	95.8	1	121	3.3	5	6RR	6ZR
SMA6J78(C)A	78	86.7	99.7	1	126	3.2	5	6RT	6ZT
SMA6J85(C)A	85	94.4	108.2	1	137	2.2	5	6RV	6ZV
SMA6J90(C)A	90	100	115.5	1	146	2.1	5	6RX	6ZX
SMA6J100(C)A	100	111	128.0	1	162	1.9	5	6RZ	6ZZ
SMA6J110(C)A	110	122	140.5	1	177	1.7	5	6SE	6VE
SMA6J120(C)A	120	133	153.0	1	193	1.6	5	6VG	6VG
SMA6J130(C)A	130	144	165.5	1	209	1.4	5	6VK	6VK
SMA6J150(C)A	150	167	192.5	1	243	1.2	5	6VM	6VM
SMA6J160(C)A	160	178	205.0	1	259	1.2	5	6SP	6VP
SMA6J170(C)A	170	189	217.5	1	275	1.09	5	6SR	6VR
SMA6J188(C)A	188	209	231.0	1	328	0.91	5	6SS	6VS
SMA6J200(C)A	200	224	247.0	1	332	0.89	5	6SV	6VV
SMA6J210(C)A	210	237	263.0	1	340	0.86	5	6SW	6VW
SMA6J220(C)A	220	246	272	1	352	0.8	5	6SZ	6VZ
SMA6J250(C)A	250	279	309	1	405	0.75	5	6VM	6VM
SMA6J300(C)A	300	335	371	1	486	0.7	5	6TE	6UE
SMA6J400(C)A	400	447	494	1	648	0.6	5	6TK	6UK
SMA6J440(C)A	440	492	543	1	713	0.6	5	6TM	6UM

I-V Curve Characteristics

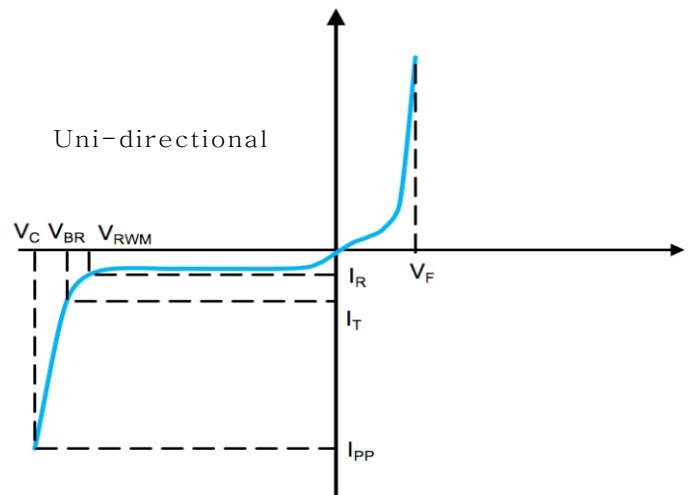
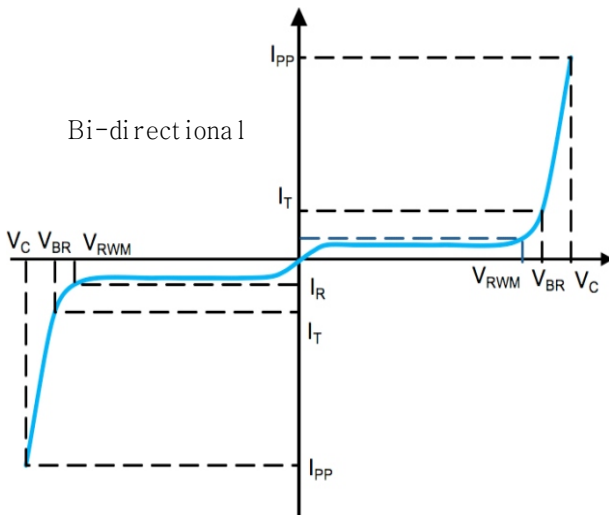

P_{PPM} Peak Pulse Power Dissipation - Max power dissipation

V_{RWM} Reverse Stand-off Voltage - Maximum voltage that can be applied to TVS without operation

V_{BR} Breakdown Voltage – Maximum voltage that flows though the TVS at a specified current (I_T)

V_C Clamping Voltage – Peak vltage measured across the TVS at a specified I_{PPM} (peak impulse current)

I_R Reverse Leakage Current – Current measured at V_R

V_F Forward Voltage Drop for Uni-directional

Soldering parameters

Reflow Condition		Pb-Free assembly (see as below)
Pre Heat	-Temperature Min ($T_{s(min)}$)	+150 °C
	-Temperature Max($T_{s(max)}$)	+200 °C
	-Time (Min to Max) (ts)	60-180 secs.
Average ramp up rate (Liquid us Temp (T_L) to peak)		3 °C/sec. Max
$T_{s(max)}$ to T_L - Ramp-up Rate		3 °C/sec. Max
Reflow	-Temperature(T_L)(Liquid us)	+217 °C
	-Temperature(t_L)	60-150 secs.
Peak Temp (T_p)		+260(+0/-5) °C
Time within 5 °C of actual Peak Temp (t_p)		30 secs. Max
Ramp-down Rate		6 °C/sec. Max
Time 25 °C to Peak Temp (T_p)		8 min. Max
Do not exceed		+260 °C

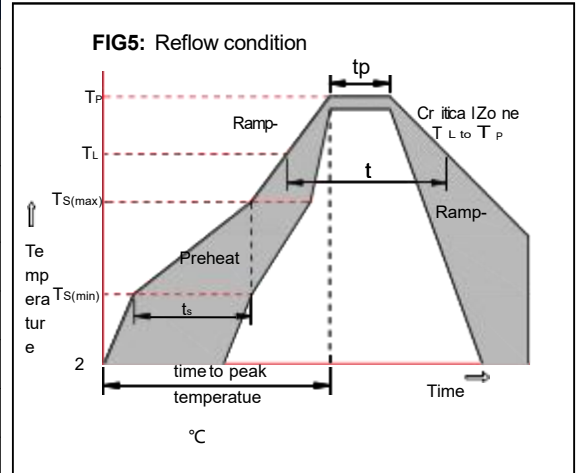

Package Dimensions & Suggested Pad Layout

SMA

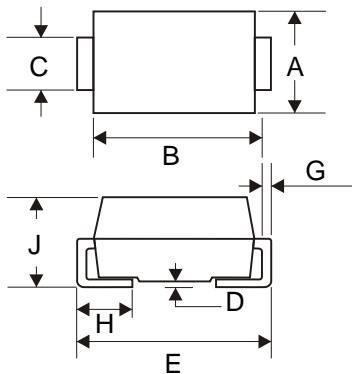

SMA		
Dim	Min	Max
A	2.40	2.79
B	3.99	4.50
C	1.32	1.47
D	-	0.20
E	4.93	5.28
G	0.15	0.31
H	0.76	1.52
J	1.98	2.29
All Dimensions in mm		

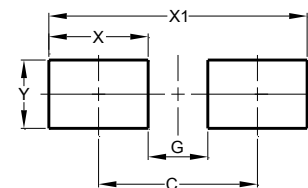

Dimensions	Value (in mm)
C	4.20
G	1.90
X	2.30
X1	6.50
Y	2.00

Tape & reel specification

Tape		Symbol	Dimension (mm)		
<p>SECTION : A-A</p> <p>SECTION : B-B</p>		P0	4.00±0.20		
		P1	4.00±0.20		
		P2	2.00±0.20		
		D0	1.60±0.20		
		D1	1.60±0.20		
		E	1.75±0.20		
		F	5.50±0.15		
		W	12.00±0.25		
		A0	2.75±0.20		
		B0	5.25±0.20		
		K0	2.45±0.25		
		T	0.20±0.10		
		7" Reel		D2	176.0±5.0
				D3	55.0Min.
D4	14.0±2.5				
W1	14.0±2.5				
Quantity: 2000PCS					
13" Reel		D5	330.0±5.0		
		D6	73.0Min.		
		D7	14.0±2.5		
		W2	14.0±2.5		
		Quantity: 5000PCS			