

MDDG03R04Q

30V N-Channel Enhancement Mode MOSFET

1. Description

This N-Channel MOSFET is produced using MDD Semiconductor's advanced Power Trench process that incorporates Shielded Gate technology. This process has been optimized to minimize on-state resistance and yet maintain superior switching performance with best in class soft body diode.

2. Features

- Max $R_{DS(on)}$ = 4.3 m Ω at $V_{GS} = 10$ V, $I_D = 20$ A
- Extremely Low Reverse Recovery Charge, Q_{rr}
- 100% UIS Tested
- RoHS Compliant

3. Application

- Synchronous Rectification for ATX / Server / Telecom PSU
- Motor Drives and Uninterruptible Power Supplies
- Micro Solar Inverter

4. Absolute Maximum Ratings ($T_A=25^\circ\text{C}$ unless otherwise noted)

Parameter	Symbol	Value	Unit
Drain-Source Voltage	V_{DS}	30	V
Gate-Source Voltage	V_{GS}	± 20	V
Continuous Drain Current (Note 1)	I_D	80	A
Pulsed Drain Current (Note 2)	I_{DM}	300	A
Single Pulsed Avalanche Energy (Note 3)	E_{AS}	52.5	mJ
Thermal Resistance, steady-state	$R_{\theta JA}$	50	$^\circ\text{C}/\text{W}$
Power Dissipation	P_D	30	W
Junction Temperature	T_J	-55~+150	$^\circ\text{C}$
Storage Temperature	T_{stg}	-55~+150	$^\circ\text{C}$

Note: 1) Calculated continuous current based on maximum allowable junction temperature.

2) Repetitive rating, pulse width limited by max. junction temperature.

3) E_{AS} condition : $T_J=25^\circ\text{C}$, $V_{DD}=15\text{V}$, $V_{GS}=10\text{V}$, $L=0.5\text{mH}$, $R_G=25\Omega$, $I_{AS}=14.5\text{A}$.

5. Pinning information

Pin	Symbol	Description	Simplified outline	Equivalent Circuit	Marking	Package
4	G	Gate			MDD G03R04Q	PDFN3*3-8L
5-8	D	Drain				
1-3	S	Source				

6. $T_A=25^\circ\text{C}$ unless otherwise specified

Symbol	Parameter	Condition	Min	Typ	Max	Unit	
$V_{(BR)DSS}$	Drain-Source Breakdown Voltage	$V_{GS}=0V, I_D=250\mu A$	30	—	—	V	
I_{GSS}	Gate-Source Leakage Current	Forward	$V_{GS}=20V$	—	—	100	nA
		Reverse	$V_{GS}=-20V$	—	—	-100	nA
I_{DSS}	Drain-Source Leakage Current	$V_{DS}=30V, V_{GS}=0V$	—	—	1	μA	
$V_{GS(TH)}$	Gate Threshold Voltage	$V_{DS}=V_{GS}, I_D=250\mu A$	1.0	1.5	2.5	V	
$R_{DS(ON)}$	Drain-Source On-State Resistance	$V_{GS}=10V, I_D=20A$	—	3.5	4.3	m Ω	
		$V_{GS}=4.5V, I_D=15A$	—	5.5	6.9	m Ω	

7. Dynamic Electrical Characteristics

Symbol	Parameter	Condition	Min	Typ	Max	Unit
C_{iss}	Input Capacitance	$V_{GS}=0V$	—	905	—	pF
C_{oss}	Output Capacitance	$V_{DS}=15V$	—	535	—	pF
C_{rss}	Reverse Transfer Capacitance	$f=1MHz$	—	24	—	pF
Q_g	Total Gate Charge	$V_{GS}=10V$	—	70	—	nC
Q_{gs}	Gate Source Charge	$V_{DS}=30V$	—	15	—	nC
Q_{gd}	Gate Drain Charge	$I_D=15A$	—	20	—	nC

8. Switching Characteristics

Symbol	Parameter	Condition	Min	Typ	Max	Unit
$t_{d(on)}$	Turn on Delay Time	$V_{GS}=10V$ $V_{DD}=15V$ $I_D=30A$ $R_G=3\Omega$	—	10	—	ns
t_r	Turn on Rise Time		—	25	—	ns
$t_{d(off)}$	Turn Off Delay Time		—	50	—	ns
t_f	Turn Off Fall Time		—	22	—	ns

9. Source Drain Diode Characteristics

Symbol	Parameter	Condition	Min	Typ	Max	Unit
V_{SD}	Drain-Source Diode Forward Voltage	$I_S=30A, V_{GS}=0V$	—	0.8	—	V
t_{rr}	Body Diode Reverse Recovery Time	$I_F=20A$	—	20	—	ns
Q_{rr}	Body Diode Reverse Recovery Charge	$di/dt=100A/\mu s$	—	10	—	nC

10. Test Circuits And Waveforms

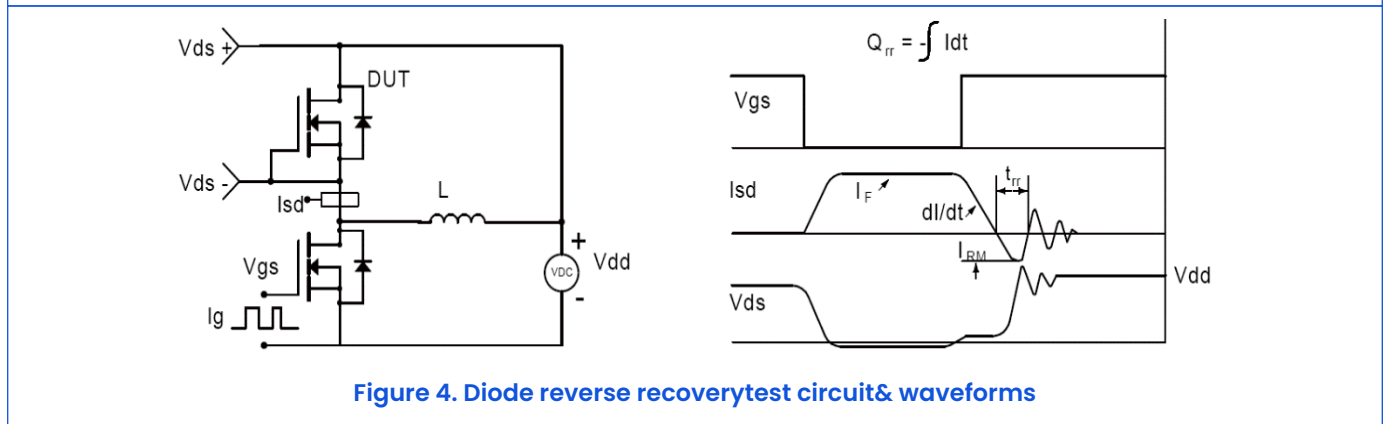
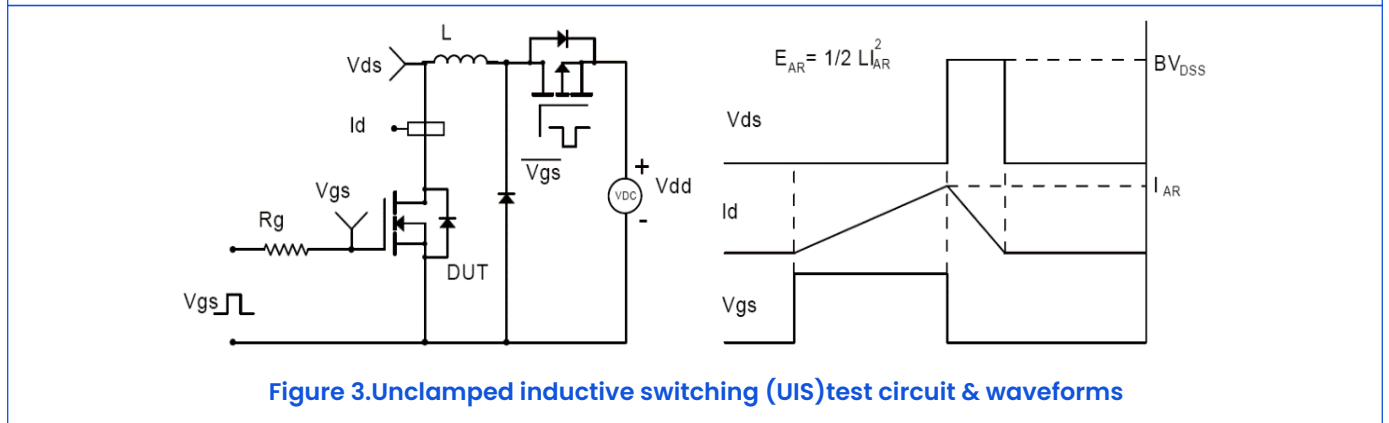
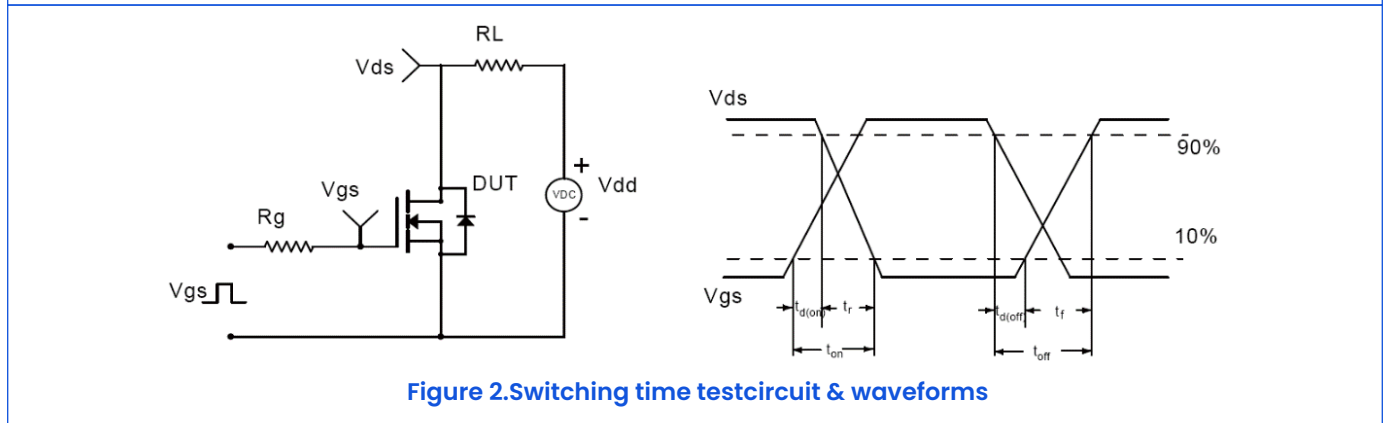
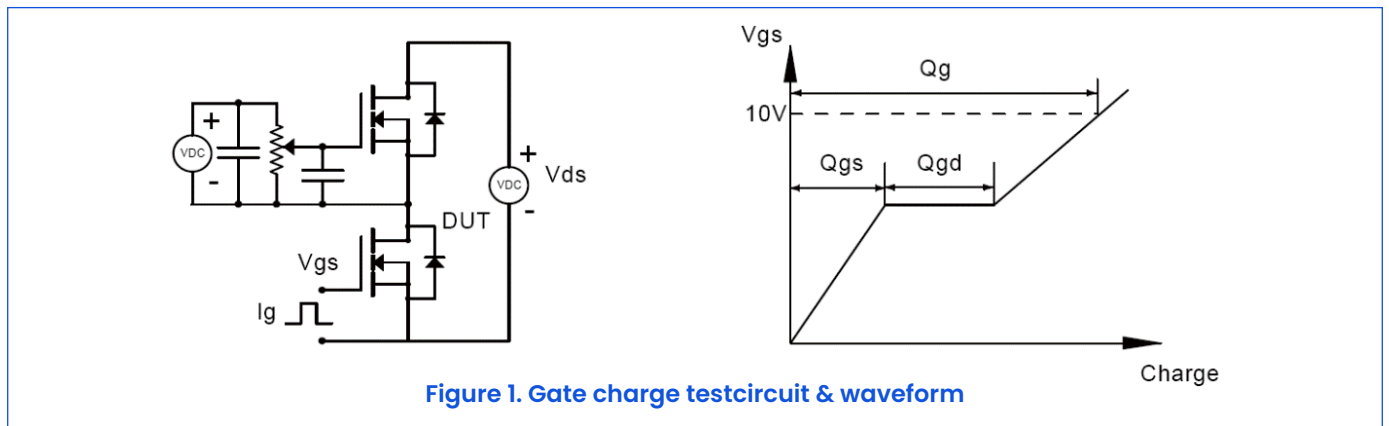

II. Electrical Characteristics Diagrams

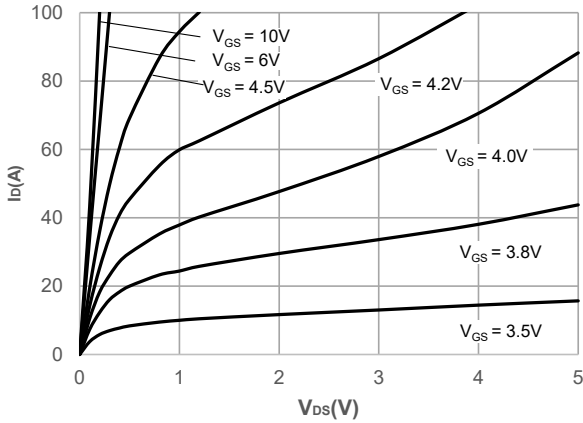

Figure 1. Typ. output characteristics

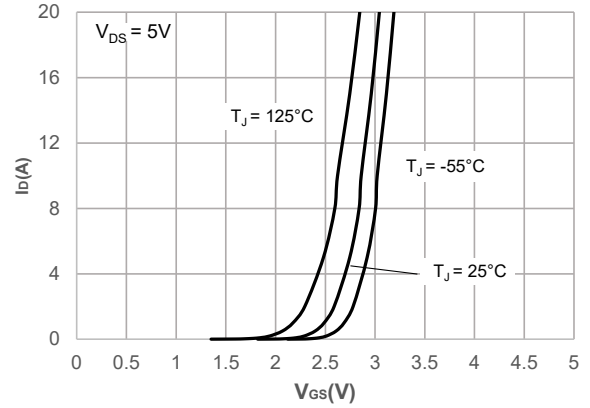

Figure 2. Typ. transfer characteristics

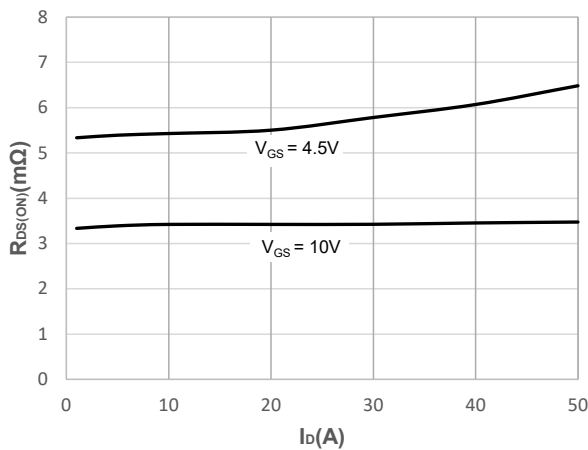

Figure 3. On-Resistance vs. Drain Current

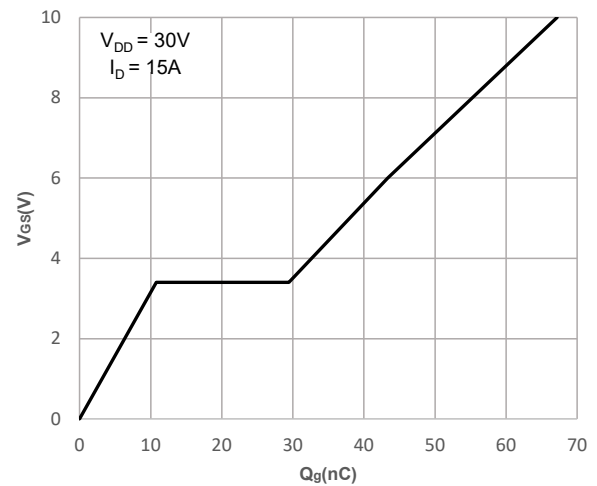

Figure 4. Gate Charge Characteristics

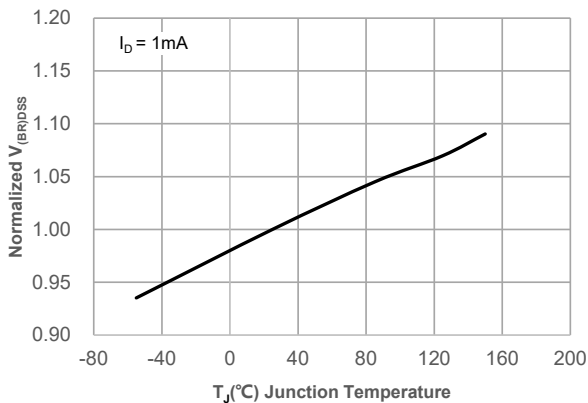

Figure 5. Normalized Breakdown Voltage vs. Junction Temperature

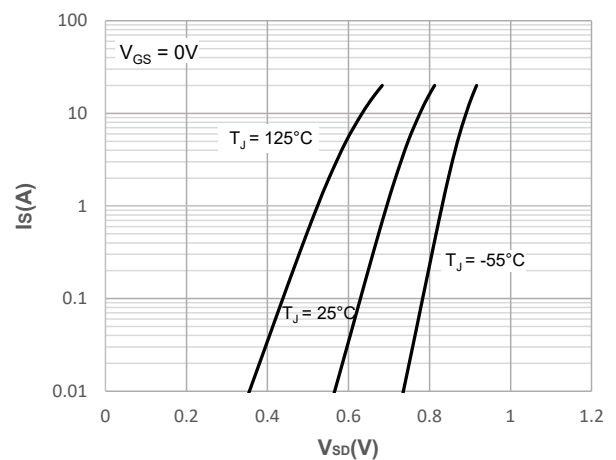
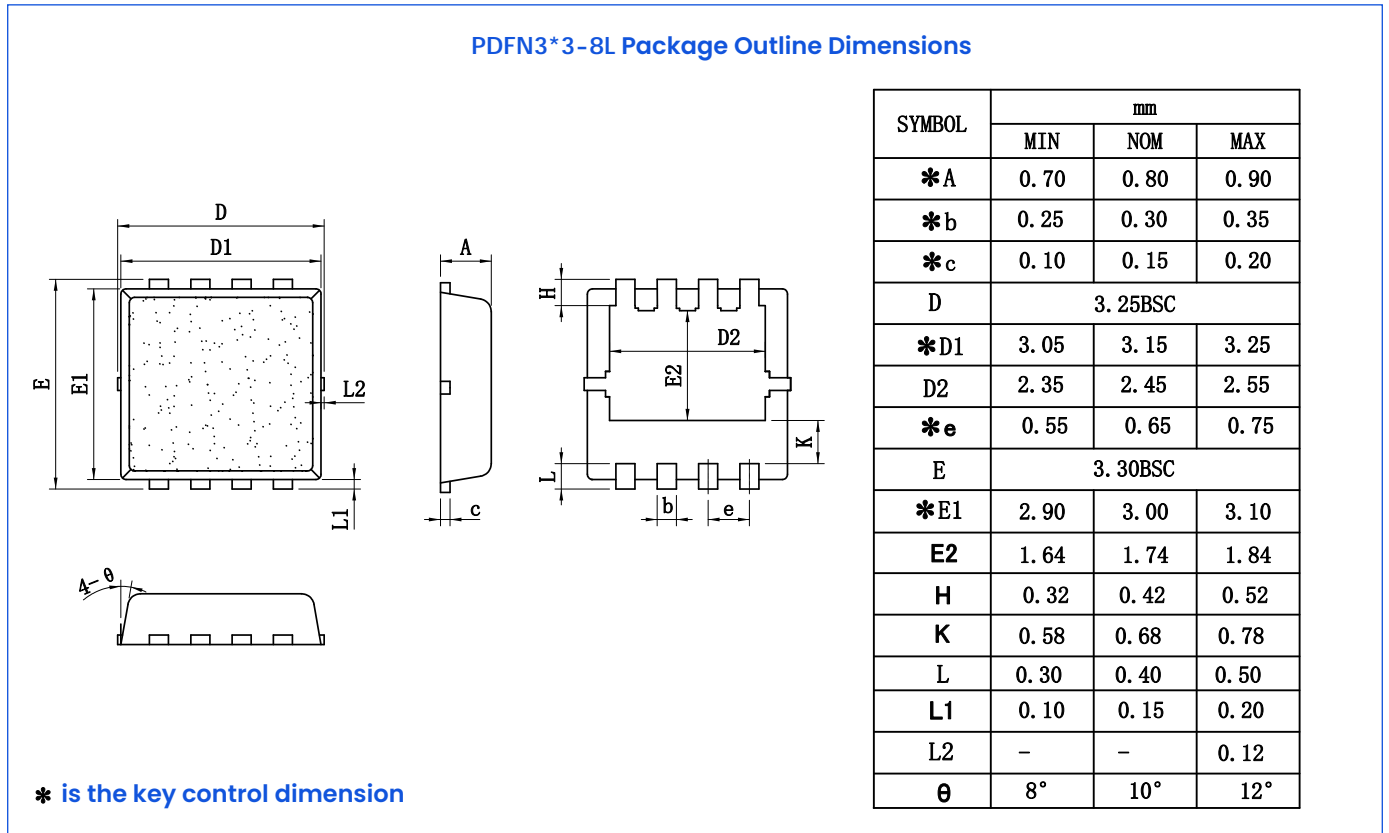

Figure 6. Forward characteristic of body diode

12. Outline Drawing



13. Important Notice and Disclaimer

Microdiode Electronics (Shenzhen) reserves the right to make changes to this document and its products and specifications at any time without notice. Customers should obtain and confirm the latest product information and specifications before final design, purchase or use.

Microdiode Electronics (Shenzhen) makes no warranty, representation or guarantee regarding the suitability of its products for any particular purpose, nor does Microdiode Electronics (Shenzhen) assume any liability for application assistance or customer product design. Microdiode Electronics (Shenzhen) does not warrant or accept any liability with products which are purchased or used for any unintended or unauthorized application.

No license is granted by implication or otherwise under any intellectual property rights of Microdiode Electronics (Shenzhen).

Microdiode Electronics (Shenzhen) products are not authorized for use as critical components in life support devices or systems without express written approval of Microdiode Electronics (Shenzhen).