

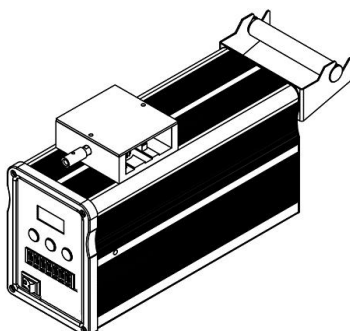

# QUICK 376DI Self-feeder Soldering Station

## Instruction Manual



**Thank you for purchasing our products. Please keep the instruction manual properly for future reference.**



# Contents

1. Safety Instructions.....	1
2. Overview.....	2
3. Product Characteristics.....	2
4. Product Specifications.....	3
5. Functional Descriptions.....	4
5.1. Dimensions.....	4
5.2. Part Descriptions.....	5
5.3. Key Descriptions.....	8
6. Connection.....	8
7. Operation.....	11
8. Parameters Settings.....	12
9. Temperature Settings.....	13
9.1.Real-time Temperature Settings.....	14
9.2.General Temperature Settings.....	14
10. Password Settings.....	15
11. Working Modes Settings.....	16
12. Temperature Calibration.....	19
13. Maintenance of Tips.....	19
14. Selection of Tips.....	20
15. Guide for Replacing Heater.....	21
15.1. Steps for Removing Heater.....	21
15.2. Steps for Replacing Heater.....	21
16. Replacing Cutting Blade.....	22
17. Troubleshooting.....	26
18. List of Tips.....	27

# 1.Safety Instructions



## CAUTION

- During the installation and use of this product, all electrical safety regulations of the country and regions must be strictly observed.
- The power supply must be disconnected when disassembling the product. Do not operate with power on.
- If the product does not work properly, please contact the supplier or our company, and do not disassemble or change the product in any way. We are not responsible for any problems caused by unauthorized maintenance or modification.



## WARNING

- The product should be used away from places where there is magnetic interference.
- Don't install the product in a place where the surface is easy to shake or be impacted, as it may damage the product.
- Don't install the product in places where it may be exposed to rain or moisture.
- Don't use in flammable and explosive environments.
- After using the station, the tip temperature will be quite high, which is easy to burn and may cause dangerous accidents.
- Don't knock workbench with the soldering pencil to remove residual flux, which may seriously damage the soldering pencil.
- When the soldering pencil is not in use, please turn off the power to prolong its life.
- Please unplug the power cord when the product is not used for a long time.

## 2.Overview

This self-feeder soldering station is a lead-free soldering device with automatic solder feeding and breaking. Microcomputer display, push-button temperature adjustment and with automatic sleeping function, digital temperature calibration, easy and fast operation. This product uses the step motor, precise solder feeding and flexible to control. The solder feeding speed, time and returning volume are all adjustable and stable, achieving ideal soldering effect , and the working efficiency is obviously improved. One-hand operation, simple and easy soldering, combined structure optimization, no need to cooperate with the soldering station, only need to cooperate with the handle to work. The equipped soldering tip adopts high frequency heating; rapid heating and thermal recovery, achieving the lead-free soldering.

## 3.Product Characteristics

- Microcomputer display, push-button temperature adjustment, digital temperature calibration and with auto sleeping function.
- Auto and manual solder feeding modes are available, and the solder feeding times can be set.
- The solder feeding speed, volume and interval time are all adjustable, with adjustable solder returning function to reduce the waste of solder.
- Configured with two kinds of feeding hose, easier and more convenient to use. The long hose is suitable for movable soldering and is provided with a manual feeding outlet switch; short hose is suitable for fixed soldering.
- Equipped with pedal switch feeding and manual switch feeding.
- Can be independently used as a lead-free soldering station.
- ESD design can prevent sensitive electronic parts from being damaged by static electricity.

## 4.Product Specifications

Model	376DI
Power consumption	90W
Voltage	AC 110V/ 220V
Temperature range	50~600°C
Temperature stability	±2°C (no load)
Tip to ground resistance	<2mV
Tip to ground potential	<2Ω
Ambient temperature(Max)	40°C
Motor	Step motor
Feeding speed	About 2.7mm/s~27mm/s (36°/s~360°/s)
Feeding length	0~150mm
Feeding interval time	0~2.7s
Backing time	0~0.9s(About 0~25mm speed: 360°/s)
Feeding mode	Auto (1~9) / Manual (0)
Dimensions(L*W*H)	99*270*156.8mm
Weight	About 4.6kg

# 5.Functional Descriptions

## 5. 1. Dimensions

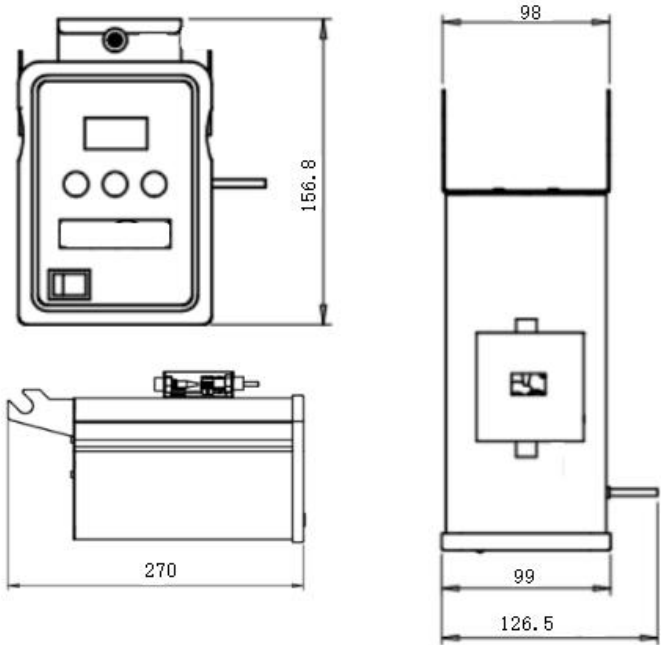

Unit: mm

# 5. 2. Part Descriptions

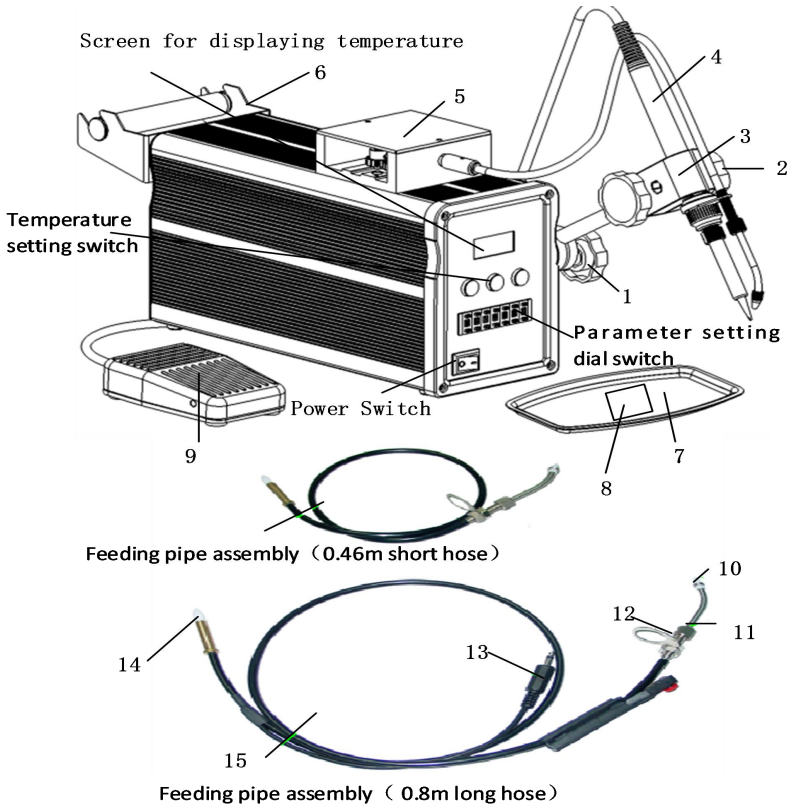

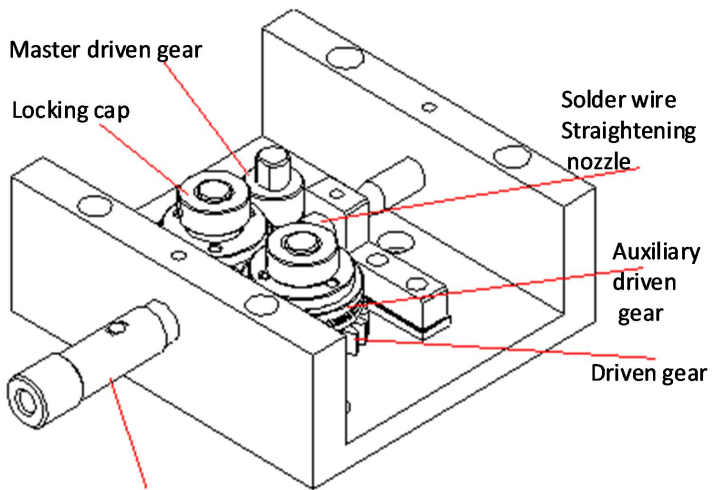

Positioning aluminum parts of feeding pipe

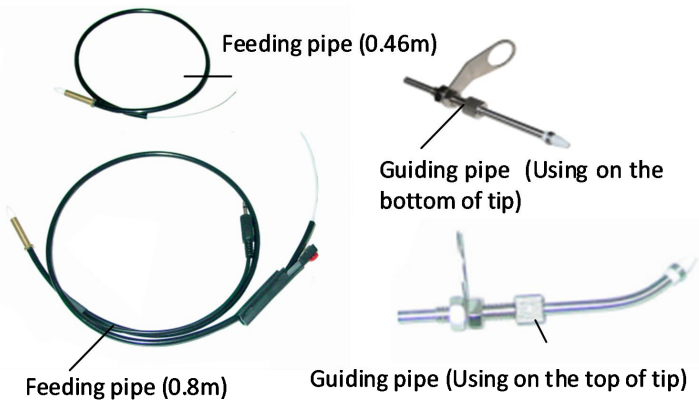

No.	Part description	Remark
1、2	Hand tighten nut	Handle bracket assembly
3	Handle clip	Handle bracket assembly
4	Lead-free soldering handle assembly	
5	Solder feeding (breaking) device	
6	Solder wire holder	Install the solder wire shaft
7	Metal plate	
8	Cleaning sponge	
9	Pedal switch	
10	Guiding pipe	
11	Locking nut	
12	Connector	
13	Plug	
14	Solder inlet head	

### 5. 3. Key Descriptions

No.	Symbols	Function Descriptions
1	▲	Temperature rise. In the working state, press the key temperature rises by 1 °C; long press the key, the temperature rises quickly.
2	*	After temperature adjustment, press to save the temperature.
3	▼	Temperature decrease. In the working state, press the key temperature decreases by 1 °C; Long press the key, the temperature decreases quickly.
4	* / ▲ / ▼	Press and hold " *" key, then press "▲" and "▼" keys at the same time to enter temperature calibration.

## 6.Connection

### 1) Installing handle bracket assembly

Screw off ① Hand tighten nut on the station, install the handle bracket assembly on the screw, and screw on the nut.

### 2) Installing guiding pipe assembly

There are two types of solder feeding guide pipe assemblies (optional): 0.46m short hose and 0.8m long hose, and the installation method of them are slightly different.

#### **Installing short hose:**

Screw out black insert on handle assembly of the soldering handle, put the handle into ⑫ Connector, and tighten it. Loosen the fixed screw of the positioning aluminum parts of feeding pipe on the station, insert the solder inlet head (on the feeding pipe assembly) into the feeding pipe positioning part, and then slightly tighten the screw.

#### **Installing long hose:**

Screw out black insert on handle assembly of the soldering handle, put the handle into ⑫ Connector, and tighten it. Loosen the fixed screw of the positioning aluminum parts of feeding pipe on the station, insert the ⑭ Solder inlet head (on the feeding pipe assembly) into the feeding pipe positioning part, and then slightly tighten the screw. Insert the ⑬ Plug into the socket on the back of the station.

### **3) Installing the pedal switch or manual switch (optional)**

- a) Insert the plug of the pedal switch into the two-core socket on the back of the station.
- b) Insert the plug of the manual switch into the socket and connect the handle socket.

### **4) Installing solder wire**

- a) Thread the solder wire shaft into the skeleton of the solder wire and install it on the ⑥ Solder wire holder at the tail of the station. Clamp the groove at that two ends of the solder wire shaft to the holder.
- b) Pull out the solder wire and thread it through the solder inlet head, trigger the the pedal switch or manual switch to make the solder wire slowly insert into the solder feeding positioning pipe.
- c) Set the feeding "MODE" of the station to "0" (manual), plug in the power plug, turn on the power switch "POWER", straighten the feeding

pipe as much as possible, and step on the pedal switch until the solder wire is sent out. Turn off the power switch.

### **5) Installing soldering handle**

Unscrew the ②Hand tighten nut of the bracket assembly and remove the ③Handle clip. Place the soldering handle in another clip, install the removed clip (make the handle clamped in the middle), and screw on the ②Hand tighten nut. Connect the plug of the soldering handle wire to the six-core metal socket on the back of the station and tighten it by hand.

### **6) Adjusting the position of the guiding pipe and tip**

The combination position of the pipe and the soldering tip can be changed by rotating the ⑫Connector; unscrewing the ⑪Locking nut of the guiding pipe and rotating the ⑩ Guiding pipe can also change the combination position.

### **7) Adjusting the direction of the soldering handle**

When adjusting the direction, first loosen the hand tighten nut in the corresponding direction, and then adjust it. Unscrew the hand tighten nut at the lower end of the bracket assembly, rotate the bracket assembly or the bracket rod to adjust the position of the soldering handle, after adjustment tighten the nut again. The position of the soldering handle can also be adjusted by unscrewing the two ①②Hand tighten nuts at the upper end of the bracket and rotating the ③Handle clip.

### **△Notes:**

- When unscrewing the insert to install the connector, be careful to avoid damage the heating element.
- The feeding pipe shall not be excessively bent or forcibly rotated to prevent the blocking of solder wire.
- When the station is working, the temperature of the soldering tip will be very high, please pay attention to avoid scalding.

## 7. Operation

**⚠Notes:** Make sure the specifications of the cutting blade and the solder wire match. For example, a 0.8mm blade can only be used to cut 0.8mm solder wire.

1) Set working parameter including temperature, working mode, feeding length, feeding interval time, feeding speed, feeding mode, feeding force, and returning, and then carrying out corresponding operation according to selected feeding mode.

a) Manual mode:

Turn on the power switch, LED displays the temperature, and enters the working state. Step on the pedal switch or press the red button switch to work. After releasing, it will return the solder once and then stop working. The functions of feeding length, feeding interval time and feeding mode do not work in manual mode.

b) Auto mode:

Turn on the power switch, LED displays the temperature, enters the working state, step on the pedal switch or press the red button switch to work according to the set parameters. All the functions work.

2) Auto sleeping: if the working mode with sleeping function is selected and it is not used for 20 minutes, the screen displays , indicating that the unit enters the sleeping state.

3) Wake up:

a) Turn off the power switch and turn it on again.

b) Step on the pedal switch.

c) Pick up the soldering handle.

4) Auto shutdown: If the station does not wake up after 40 minutes in the sleeping state, the power supply of the station will be automatically cut off, and the display screen will not display, indicating the station has been automatically shut down.

5) After auto shutdown, the power switch needs to be turned on again to enter the working state.

## 8.Parameters Settings

### Feeding speed

Use the dial switch to set, press the "+" on the dial, the number of the corresponding digit will increase by one; press the "-" the number will decrease by one.

The feeding speed is set by 1 bit, and 0 ~ 9 indicates the adjustable range of feeding speed is about 2.7mm/s ~ 27mm/s (36°/s ~ 360°/s). The resolution is 2.7 mm/s, that is, each 1 value represents the feeding speed is 2.7 mm/s (36°/s).

For example, when it is set to 0, the feeding speed is the slowest, 2.7 mm/s (36°/s); when it is set to 9, the feeding speed is the fastest, 27mm/s (360°/s).

Toggle the dial switch "SPEED" to select the value. The value setting way is the same as feeding length.

### Feeding length

The feeding length adopts the angle system, that is, the rotation angle of the motor indicates the length of feeding.

Use the dial switch to set, toggle the dial switch "LENGTH", and select the corresponding value according to the work requirements. Press the "+" on the dial to increase the corresponding position digit by one and press the "-" to decrease by one. Adjustable range: 0 ~ 150mm.

The feeding length is set in 3 digits, 001 ~ 999 indicates the feeding length is 0.15-150mm, and each 1 value indicates 0.15mm.

For example, when the value is set as 001, the feeding angle is 1.8 degrees, and the feeding length is 0.15mm; when the value is set as 002, the feeding angle is 3.6 degrees, and the length is 0.3 mm; when the longest value 999 is selected, the feeding angle is 1798.2 degrees, length for about 150mm.

### Interval time

Feeding interval time refers to the interval time of each feeding when the automatic feeding is more than twice.

The interval time is set by 1 bit, and 0 ~ 9 represents the adjustable range of 0 ~ 2.7s. The resolution is 0.3s, that is, each 1 value represents 0.3s. The value setting way is the same as the feeding speed.

For example, when the value is set to 1, the interval time is 0.3s; when the value is set to 2, the interval time is 0.6s; when it is set as 9, the time is the longest, and the interval is 2.7s;

Toggle the dial switch " INTERVAL TIME "to select the value.

### **Feeding mode**

Toggle the dial switch " MODE "to select the value.

The feeding mode is set by 1 bit, and the value selection mode is the same as above. Each value corresponds to the following functions:

0: Manual feeding	1: Auto feeding 1 time
2: Auto feeding 2 times	3: Auto feeding 3 times
4: Auto feeding 4 times	5: Auto feeding 5 times
6: Auto feeding 6 times	7: Auto feeding 7 times
8: Auto feeding 8 times	9: Auto feeding 9 times

It will return after every time feeding.

### **Return**

Toggle the dial switch " RETURN "to select the value.

The return time is set by 1 bit, 0 ~ 9 represents 0 ~ 0.9s, and the resolution is 0.1s, that is, each 1 value represents 0.1s. (Note: The return speed is fixed during return and cannot be adjusted.)

For example, when the set value is 0, the return time is 0s, and the return length is 0mm; when the value is set to 1, the return time is 0.1s and the return length is about 2.8mm; when the value is set to 2, the return time is 0.2s, and the return length is about 5.6mm; when the value is set to 9, the return time is 0.9s, return length is about 25mm. Adjustable range: 0 ~ 0.9s (about 0 ~ 25mm).

## **9. Temperature Settings**

 **Note:**

**\*Input the correct password or the initial password "000".**

**\*Turn off the power switch when setting the temperature , and the setting value will not be saved.**

**\*If the set temperature value is out of the settable range, the display screen will return to the hundreds digit blinking. Please input the correct temperature value again.**

## **9.1.Real-time Temperature Settings**

During working mode,set the temperature rapidly

**Temperature increase:** press "▲" key set temperature increase by 1°C; long press to increase rapidly.

**Temperature decrease:** press "▼" key set temperature decrease by 1°C; long press to decrease rapidly.

## **9.2.General Temperature Settings**

"▲" or "▼": number selection key; "\*": digit selection key.

1) Long press the "\*" key, and the leftmost digit (hundreds) will blink. It indicates to enter the temperature setting mode, and the hundreds digit can be set.



2) Press the "▲" or "▼" key to change the displayed value of hundreds. The operation method of tens and ones are the same as of hundreds.

## 10.Password Settings

Note: You must input the correct password to set the working mode and change the password. If the input password is wrong, it will return to the working mode. The initial password is: "000"

### 10.1. Input Correct Password

#### Enter the password modification mode

- 1) Turn off the power switch. Long press the "▲" and "▼" keys at the same time, then turn on the power switch.
- 2) Long press the "▲" and "▼" keys until the screen displays: .
- 3) When the screen displays , entering into password settings.

#### Input the initial password

Press "\*" key, the screen displays , and the hundreds digit blinks, indicating entering into password setting mode, the hundreds digit number is adjustable. Press the "▲" or "▼" key to change the displayed value. After selecting the three digits of the password, press the "\*" key for confirmation.

#### If the password input is wrong

If the screen displays the current input password for two seconds, the station enters the working state, indicating the input password is wrong, and the temperature setting and temperature calibration cannot be operated.

#### If the password input is right

If the screen displays , indicating the input password is correct. After displaying about 4 seconds, the station enters the working state, the temperature setting can be operated.

### 10.2. New Password Settings



- 1) After the station enters the new password input mode, the screen displays , press the "▲" or "▼" key, the hundreds digit blinks.

2) Press the "▲" or "▼" key to change the value. After selection, press the "\*" key to confirm and enter the ten-digit number selection. The selection method of ten-digit and one-digit numbers are the same as hundred-digit numbers. After selecting the one digit, press the "\*" key to confirm and enter the second input of the password. The second password setting method is the same as the first password setting method.

3) **If the password input twice are different:** the screen displays "Err", indicating that the new password setting is unsuccessful and the password remains unchanged.

4) **If the password input twice are same:** the screen displays "OK", indicating that the password is set successfully. After shutdown and restart, the new password takes effect.

## 11. Working Modes Settings

1) When the screen display:  , press "▲" and "▼" at same time and it will display  , indicating that the station has entered in working modes settings state. Press "▲" or "▼" to change the value.

2) After selecting working modes, press "\*" to save.

The meaning of the displayed numbers is shown in the following "Working Modes Sheet". Note: "X" represents the original working mode number.

 **Warning:** High-temperature operation will cause serious oxidation and damage to the heater and tip, shortening the service life. Please choose carefully and use low-temperature as much as possible.

## Working Modes Sheet

Working Modes	Handle Type	Adjustable Temperature Range	Applicable for High-frequency	Notes
1	Electromagnetic Soldering Tip	200°C-420°C	90W Soldering Station	With Auto-sleeping and Auto-shutdown
2	Electromagnetic Tweezers Soldering Iron or Special Large Tip	200°C-420°C	60W, 90W Soldering Station	
3	Electromagnetic Soldering Tip	50°C-600°C	90W Soldering Station	
4	Electromagnetic Soldering Tip	50°C-420°C	60W Soldering Station	
5	Electromagnetic Soldering Tip	50°C-420°C	90W Soldering Station	
6	Electromagnetic Soldering Tip	200°C-480°C	90W Soldering Station	
7	Electromagnetic Soldering Tip	200°C-480°C	90W Soldering Station	
0.	Electromagnetic Soldering Tip	200°C-420°C	60W Soldering Station	Without Auto-sleeping

1.	Electromagnetic Soldering Tip	200°C-420°C	90W Soldering Station
2.	Electromagnetic Tweezers Soldering tip or Special Large Tip	200°C-420°C	60W, 90W Soldering Station
3.	Electromagnetic Tweezers Wire Stripper	50°C-600°C	90W Soldering Station
4.	Electromagnetic Soldering Tip	50°C-420°C	60W Soldering Station
5.	Electromagnetic Soldering Tip	50°C-420°C	90W Soldering Station
6.	Electromagnetic Soldering Tip	200°C-480°C	90W Soldering Station
7.	Electromagnetic Soldering Tip	200°C-480°C	90W Soldering Station

## 12. Temperature Calibration

The temperature should be recalibrated every time if the soldering tip is replaced.

- 1) Set a certain temperature.
- 2) When the temperature is stable, use the thermometer to measure the tip temperature and write down the readings.
- 3) Press the "\*" key, then press "▲" or "▼" keys at the same time to enter the temperature calibration mode.
- 4) At this time, the LED shows the hundreds digit of the temperature blinking, press the "▲" or "▼" key to select the value, press "\*" to select the digit, input the reading value of the thermometer, after completed inputting, press the "\*" key to save, the tip temperature calibration is completed.
- 5) Repeat the above steps if there's any difference between the thermometer and soldering station.

Note: \* It is recommended to use QUICK 191/192 to measure tip temperature.

\* If the password is locked, the temperature cannot be calibrated.

## 13. Maintenance of Tips

- 1) When the new tip is used for the first time, add tin to protect it when the temperature is 250 ~ 280 °C.
- 2) Select the appropriate tip size according to the size of soldering joint.
- 3) In order to prevent the oxidation of tip a layer of soldering tin should be plated before placing it into the holder.
- 4) In order to avoid rapid cooling of tip, the cleaning sponge should not be wet with too much water. But using cleaning sponge that is not wet will damage the tip and lead to failure of tinning the tip.
- 5) When the tip is oxidized due to improper use, do not clean the surface coating by grinding but use metal filament or resurrection ointment to clean it at 250 ~ 280 °C.

6) When soldering, do not apply gravity to tip and avoid adding tin to the same place to operate.

7) Try to solder at low temperature, and the temperature is usually controlled at  $320 \sim 380^{\circ}\text{C}$ . If it is necessary to solder at high temperature, please analyze the adaptability of soldering station and tip before soldering.

## 14. Selection of Tips

1) It is very important to correctly select the size and shape of tip. A suitable tip can improve the efficiency and increase the durability.

2) The size of tip is directly related to the heat capacity. For continuous soldering, the larger the tip, the less the temperature drop. In addition, because the heat capacity of the large tip is higher and relatively low temperature can be used during soldering, the tip is not easy to oxidize and the service life is relatively prolonged.

3) Generally speaking, the selection of tip size is based on the standard that it does not affect adjacent components. Selecting the geometric dimension that can fully contact with the soldering joint can improve the soldering efficiency.

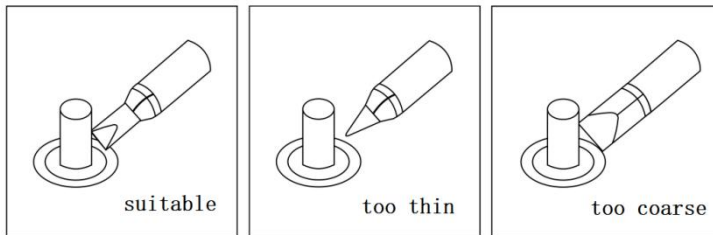

## 15. Guide for Replacing Heater

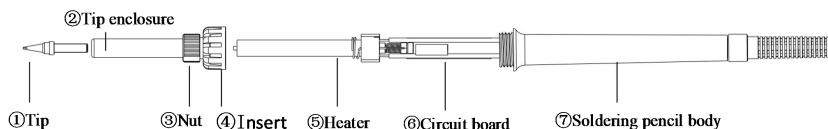

### 15. 1. Steps for Removing Heater

- 1) Unscrew the ② Tip enclosure and ③ Nut.
- 2) Take out ① Tip.
- 3) Unscrew ④ Insert.
- 4) Pull out ⑤ Heater and ⑥ Circuit board.
- 5) Disassemble the soldering part of the ⑤ Heater with soldering iron and remove it.

⚠ Note: All operating steps are performed with the power disconnected and the handle cooled.

### 15. 2. Steps for Replacing Heater

- 1) Solder ⑤ Heater to the ⑥ Circuit board, and pay attention to the positive and negative poles of the sensor.
- 2) Install ⑤ Heater into ⑦ Soldering pencil body.
- 3) Rotate the ④ Insert to the ⑦ Soldering pencil body.
- 4) Install ① Tip into ⑤ Heater.
- 5) Put ② Tip enclosure and ③ Nut on ④ Insert and tighten.

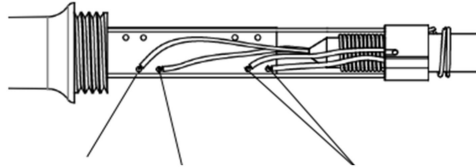

Positive pole(Red line) Negative pole(Black line) Heater wire

6) After replacing the heater, the following measurements are recommended:

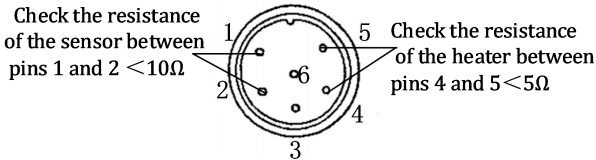

7) After replacing the heater, it is recommended to recalibrate the temperature (refer to the temperature calibration steps).

**⚠** Note: Do not burn the wiring when you replace the heater, and do not solder the wiring for too long time.

## 16.Replacing Cutting Blade

If the used solder wire or cutting blade is damaged, please replace the cutting blade of corresponding specification. Refer to the following illustration to remove and replace the cutting blade, solder feeding positioning sleeve and auxiliary driven gear. In general, only the blade needs to be replaced.

When replacing solder wires or cutting blades of different specifications, the ②Solder wire straightening nozzle and the ⑩Auxiliary driven gear need to be matched with the diameter of the solder wire for use. The replacement method is as follows:

1) **Move the feeding guide pipe assembly and the wire straightening nozzle backward so that they do not touch the ⑥Cutting blade and the ⑩Auxiliary driven gear.**

Remove the ⑫Perspex sheet, loosen the ⑮Locking screw and take out the feeding guide pipe assembly, then loosen the locking screw that fixes the ⑯Positioning aluminum parts of feeding pipe with a 1.5mm Allen wrench. Move the ⑭Guiding pipe and the ⑯Positioning aluminum parts of feeding pipe in the direction of feeding so that they do not touch the ⑥Cutting blade and the ⑩Auxiliary driven gear. Loosen the screw fixing the ② Solder wire straightening nozzle on the ③Wire feeding bracket, and move the wire straightening nozzle backward so that it does not touch the cutting blade and the auxiliary driven gear.

### **2) Remove the ⑦locking nut from ④Driven gear and the ⑩Auxiliary driven gear**

Loosen the ⑧Locking screw on the ⑦locking nut, and remove the ⑦locking nut

### **3) Remove the ④Driven gear assembly and the ⑩Auxiliary driven gear assembly**

The driven gear and the auxiliary driven gear must be removed at the same time. Hold the driven gear assembly and the auxiliary driven gear assembly at the same time and move slowly upward along the shaft until it is moved out. If necessary, replace the corresponding ⑩Auxiliary driven gear.

### **4) Replacing the ⑥Cutting blade**

The cutting blade is on driven gear assembly. Loosen the fixing screw on the ④Driven gear assembly with an Allen wrench, remove the ⑨Cutting blade platen、⑥Cutting blade、⑤Fixing plate of cutting blade in turn, then replace suitable cutting blade.

### **5) Replacing the ⑩Auxiliary driven gear**

The auxiliary driven gears are on the auxiliary driven gear assembly, and the two auxiliary driven gears need to be replaced together.

Loosen the fixing screw on ⑩Auxiliary driven gear assembly with an Allen wrench, remove the ⑨Cutting blade platen and ⑩Auxiliary driven gear in turn, then replace suitable ⑩Auxiliary driven gear. The toothed

side of the two auxiliary driven gears shall be replaced in opposite directions.

**6) Assemble the ④Driven gear assembly and the ⑩ Auxiliary driven gear assembly**

Assemble in the opposite direction of disassembly.

**7) Install the ④Driven gear assembly and the ⑩Auxiliary driven gear assembly**

The ④Driven gear assembly and the ⑩Auxiliary driven gear assembly must be sleeved on the ⑪Axis at the same time. Align the sawtooth of the ⑥Cutting blade in the driven gear assembly with the notch of the ⑩Auxiliary driven gear in the auxiliary driven gear assembly, and then smoothly fit it on the ⑪Axis. Place the ⑦locking nut onto the ④Driven gear assembly and ⑩Auxiliary driven gear assembly and secure the ⑦locking nut with the ⑧Locking screw.

**8) Install the feeding guide pipe assembly and wire straightening nozzle.**



## 17.Troubleshooting

NO.	Error Display	Troubleshooting
1	S-E	<p>The sensor is error</p> <p>If the sensor or any part of the sensor circuit fails, the screen displays "S-E", indicating the sensor may be damaged.</p>
2	H-E	<p>The heater is error</p> <p>If the soldering station cannot deliver power to the soldering heater, the screen displays "H-E", indicating that the heater is damaged.</p>

# 18.List of Tips

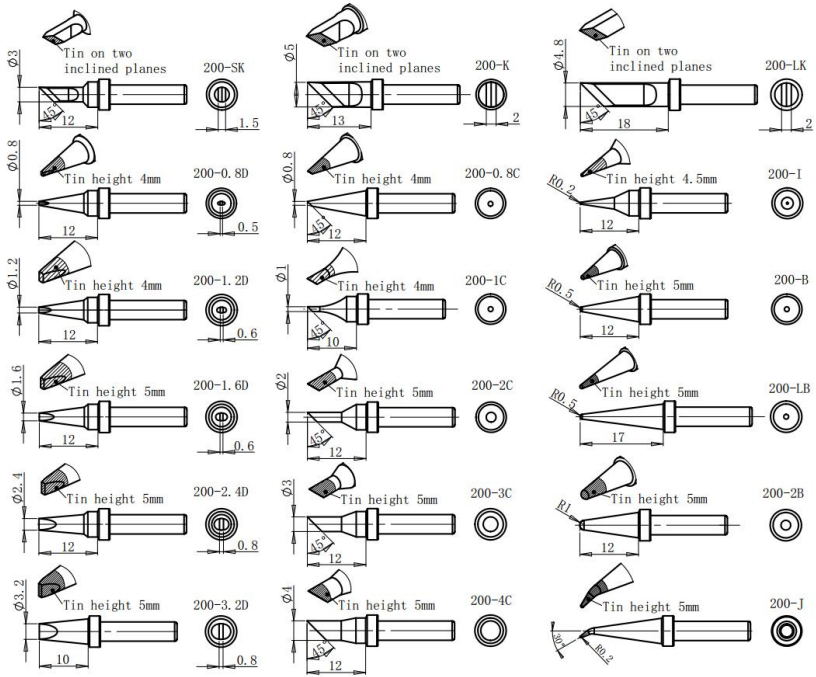

## Warranty Card

●The warranty period of this product is calculated from the date of Purchase. During the warranty period, if the product breaks down during normal use, show the original warranty card and enjoy free service in the authorized repair company(or our company). Please keep the purchase certificate and this warranty card and show it before maintenance.

●During the warranty period, the following repairs need to be paid:  
a.Unable to offer valid warranty card or certificate;

b.The purchase date, sales company and other items are not completely filled or the warranty card is altered;

c.Damage caused by failure to follow the use methods and precautions in the manual;

d.Damage caused by disassembly, repair and modification of products without authorization of the manufacturer;

e.Replacement of vulnerable and consumable parts.

●All items of the warranty card shall be completely filled in by the agent or user to obtain a 12-month warranty period.

●Please keep this warranty card properly It will not be re-offered after.

QUICK INTELLIGENT EQUIPMENT  
CO., LTD.

ADD: NO.11, FengXiang Road, Wujin  
High-Tech Industrial Development  
Zone, Jiangsu, China

TEL: 86-519-86225678

FAX: 86-519-86558599

POSTCODE: 213167

WEBSITE: www.quick-global.com

## Warranty Card

Type: \_\_\_\_\_

Model No.: \_\_\_\_\_

Serial No.: \_\_\_\_\_

Delivery Date: \_\_\_\_\_

## Warranty File Card

Type: \_\_\_\_\_

Model No.: \_\_\_\_\_

Serial No.: \_\_\_\_\_

Delivery Date: \_\_\_\_\_

Address : \_\_\_\_\_

Postcode: \_\_\_\_\_

Telephone: \_\_\_\_\_

Contact Person: \_\_\_\_\_

QUICK INTELLIGENT EQUIPMENT CO., LTD.

ADD: NO.11, FengXiang Road, Wujin  
High-Tech Industrial Development Zone,  
Jiangsu, China

TEL: 86-519-86225678

FAX: 86-519-86558599

POSTCODE: 213167

WEBSITE: [www.quick-global.com](http://www.quick-global.com)

