

Description:

This P-Channel MOSFET uses advanced trench technology and design to provide excellent $R_{DS(on)}$ with low gate charge. It can be used in a wide variety of applications.

Features:

- 1) $V_{DS}=-60V, I_D=-3A, R_{DS(ON)}<180m\ \Omega @V_{GS}=-10V$
- 2) Low gate charge.
- 3) Green device available.
- 4) Advanced high cell density trench technology for ultra low $R_{DS(ON)}$.
- 5) Excellent package for good heat dissipation.

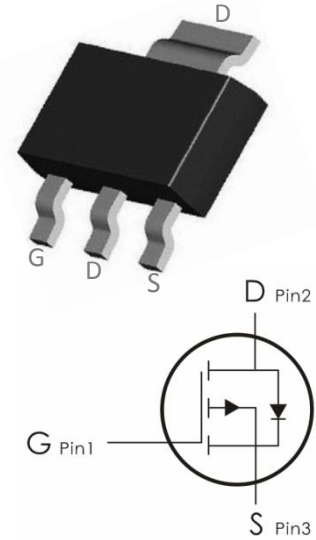

Package Marking and Ordering Information:

Part NO.	Marking	Package	Packing
TE180PG-S	E180P-S	SOT-223	4000 pcs/Reel

Absolute Maximum Ratings: ($T_A=25^\circ\text{C}$ unless otherwise noted)

Symbol	Parameter	Ratings	Units
V_{DS}	Drain-Source Voltage	-60	V
V_{GS}	Gate-Source Voltage	± 20	V
I_D	Continuous Drain Current- $T_A=25^\circ\text{C}$	-3	A
	Continuous Drain Current- $T_A=70^\circ\text{C}$	-1.8	
I_{DM}	Pulsed Drain Current ¹	-12	
P_D	Power Dissipation ³	1.5	W
T_J, T_{STG}	Operating and Storage Junction Temperature Range	-55-+150	$^\circ\text{C}$

Thermal Characteristics:

Symbol	Parameter	Max	Units
$R_{\theta JC}$	Thermal Resistance, Junction to Case ¹	48	$^\circ\text{C}/\text{W}$
$R_{\theta JA}$	Thermal Resistance, Junction to Ambient ¹	85	$^\circ\text{C}/\text{W}$

Electrical Characteristics: ($T_A=25^\circ\text{C}$ unless otherwise noted)

Symbol	Parameter	Conditions	Min	Typ	Max	Units
Off Characteristics						
BV_{DSS}	Drain-Source Breakdown Voltage	$V_{GS}=0V, I_D=250\ \mu\text{A}$	-60	---	---	V
I_{DSS}	Zero Gate Voltage Drain Current	$V_{GS}=0V, V_{DS}=-60V$	---	---	-1	μA
I_{GSS}	Gate-Source Leakage Current	$V_{GS}=\pm 20V, V_{DS}=0A$	---	---	± 100	nA
On Characteristics						
$V_{GS(th)}$	GATE-Source Threshold Voltage	$V_{GS}=V_{DS}, I_D=250\ \mu\text{A}$	-1	-16	-2.5	V
$R_{DS(ON)}$	Drain-Source On Resistance ³	$V_{GS}=-10V, I_D=-1.5A$	---	155	180	$\text{m}\Omega$
		$V_{GS}=-4.5V, I_D=-1A$	---	175	210	$\text{m}\Omega$
Dynamic Characteristics						
C_{iss}	Input Capacitance ⁴	$V_{DS}=-30V, V_{GS}=0V, f=1\text{MHz}$	---	495	---	pF
C_{oss}	Output Capacitance ⁴		---	27	--	
C_{rss}	Reverse Transfer Capacitance ⁴		---	20	---	
Switching Characteristics						
$t_{d(on)}$	Turn-On Delay Time ⁴	$V_{DS}=-30V, I_D=-1.5A,$ $R_{ENG}=3\ \Omega, V_{GS}=-10V$	---	18.9	---	ns
t_r	Rise Time ⁴		---	36.7	---	ns
$t_{d(off)}$	Turn-Off Delay Time ⁴		---	5.3	---	ns
t_f	Fall Time ⁴		---	3.4	---	ns
Q_g	Total Gate Charge ⁴	$V_{GS}=-10V, V_{DS}=-30V,$ $I_D=-1.5A$	---	15.7	---	nc
Q_{gs}	Gate-Source Charge ⁴		---	2.7	---	nc
Q_{gd}	Gate-Drain "Miller" Charge ⁴		---	1	---	nc
Drain-Source Diode Characteristics						
V_{SD}	Diode Forward Voltage ²	$V_{GS}=0V, I_{SD}=-1A$	---	---	-1.2	V
I_S	Continuous Drain Current ^{1,4}	$V_D=V_G=0V$	---	---	-3	A
I_{SM}	Pulsed Drain Current ^{2,4}		---	---	-12	A

Notes:

1. Repetitive rating, pulse width limited by junction temperature $T_{J(MAX)}=150^\circ\text{C}$.

2. The data tested by surface mounted on a 1 inch² FR-4 board with 2OZ copper, The value in any given application depends on the user's specific board design.
3. Pulse Test: Pulse width $\leq 300\mu s$, duty cycle $\leq 2\%$.
4. This value is guaranteed by design hence it is not included in the production test.

Typical Characteristics: ($T_A=25^\circ C$ unless otherwise noted)

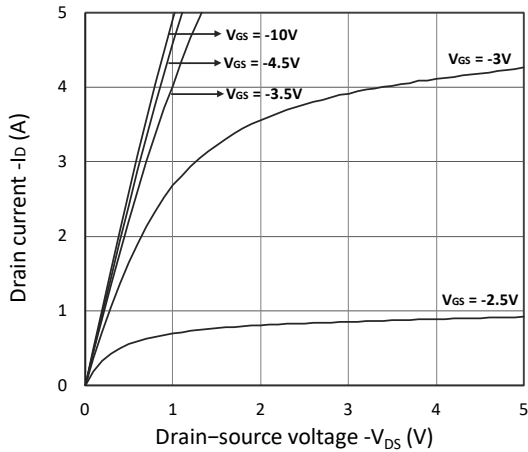

Figure 1. Output Characteristics

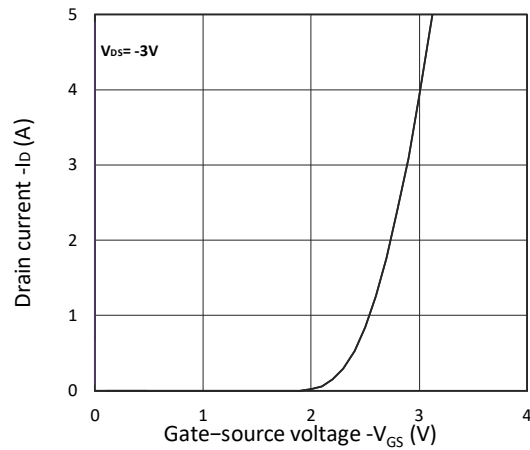

Figure 2. Transfer Characteristics

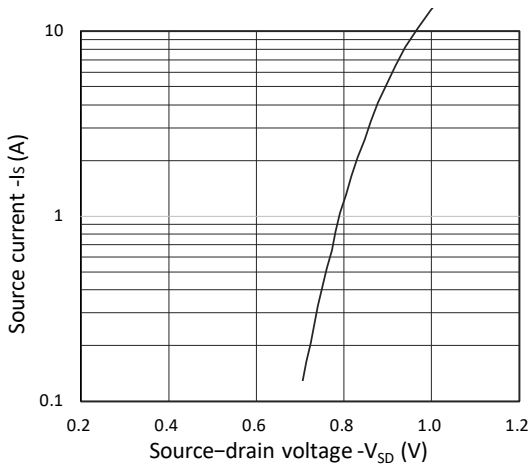

Figure 3. Forward Characteristics of Reverse

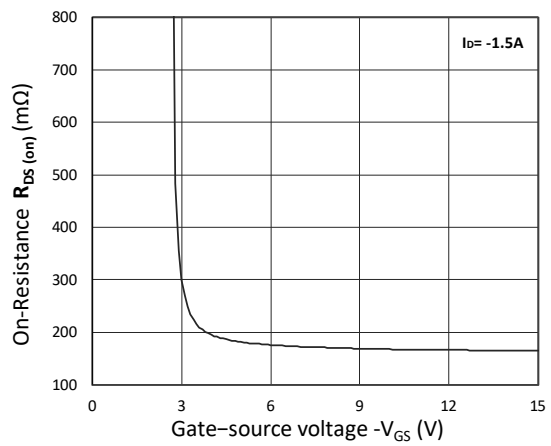

Figure 4. $R_{DS(ON)}$ vs. V_{GS}

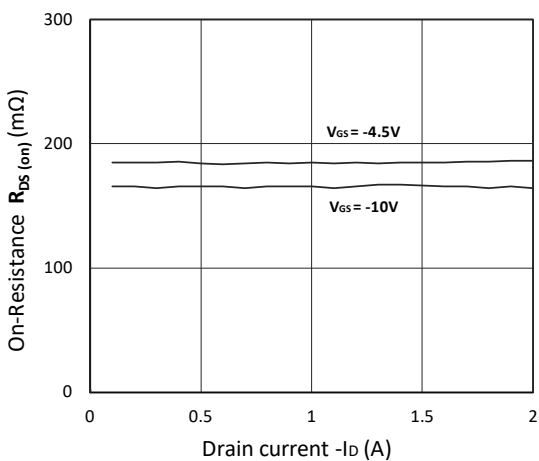

Figure 5. $R_{DS(ON)}$ vs. I_D

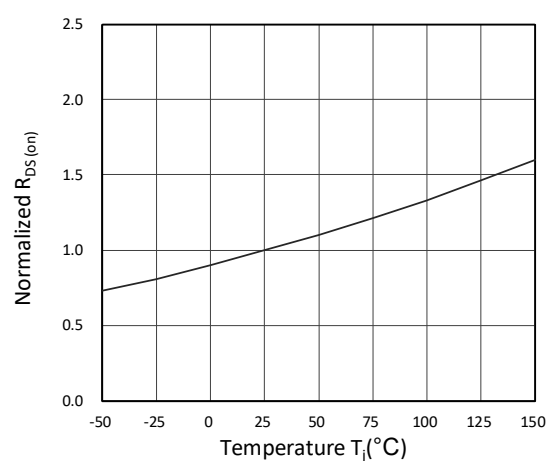

Figure 6. Normalized $R_{DS(ON)}$ vs. Temperature

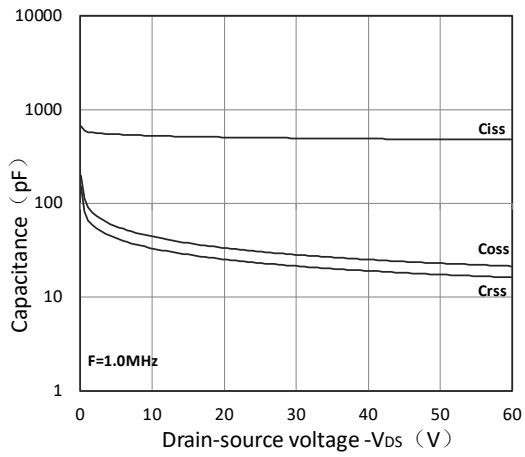

Figure 7. Capacitance Characteristics

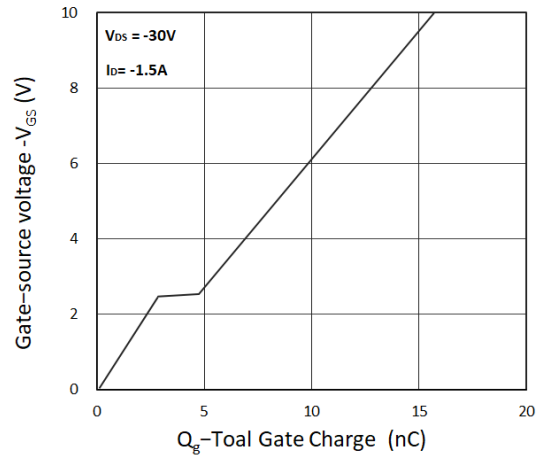
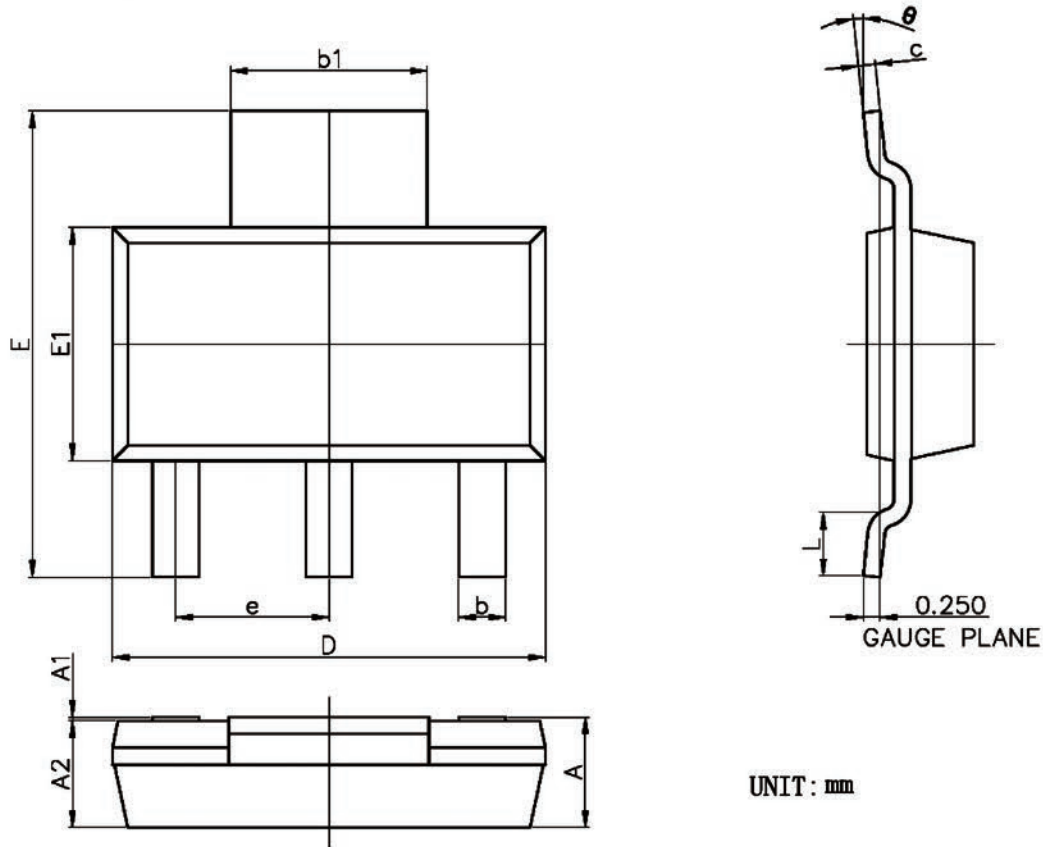

Figure 8. Gate Charge Characteristics

Sot-223 Package Outline Data



Symbol	Dimensions In Millimeters		Dimensions In Inches	
	Min.	Max.	Min.	Max.
A	—	1.800	—	0.071
A1	0.020	0.100	0.001	0.004
A2	1.500	1.700	0.059	0.067
b	0.660	0.840	0.026	0.033
b1	2.900	3.100	0.114	0.122
c	0.230	0.350	0.009	0.014
D	6.300	6.700	0.248	0.264
E	6.700	7.300	0.264	0.287
E1	3.300	3.700	0.130	0.146
e	2.300(BSC)		0.091(BSC)	
L	0.750	—	0.030	—
θ	0°	10°	0°	10°

Marking Information:

- ①: Part NO.
②: Date Code (YWWG / R)
Y: Year Code , last digit of the year
WW : Week Code (01-53)
G/R: G(Green) /R(Lead Free)

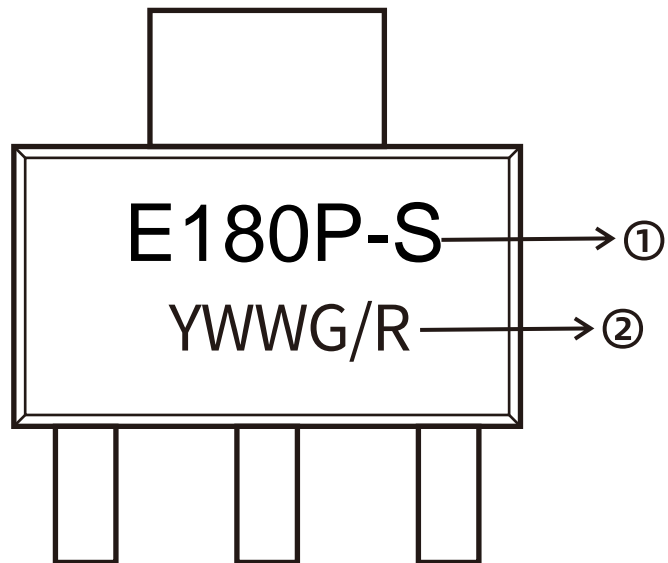
**Attention :**

- Information furnished in this document is believed to be accurate and reliable. However, Shenzhen Doingter Semiconductor Co.,Ltd. assumes no responsibility for the consequences of use without consideration for such information nor use beyond it.
 - Information mentioned in this document is subject to change without notice, apart from that when an agreement is signed, Shenzhen Doingter complies with the agreement. Products and information provided in this document have no infringement of patents.
 - Shenzhen Doingter assumes no responsibility for any infringement of other rights of third parties which may result from the use of such products and information. This document supersedes and replaces all information previously supplied.
-  Is a registered trademark of Shenzhen Doingter Semiconductor Co., Ltd. Copyright © 2013 Shenzhen Doingter Semiconductor Co.,Ltd. Printed All rights reserved.