



深圳市韩下电子有限公司

Shenzhen Hanxia Electronic Co., Ltd
Tel: 0755-23086569

承 认 书

SPECIFICATION FOR APPROVAL

产品编码
Material code:

产品名称 Project: 震动开关

规格型号 Part No: HX 1210-0S-X160

贵公司承认印 Approval signatures

料号/Part No.	签章/Signatures

日期 Date:

拟制/Drawn	黄彬	
审核/Check	张伟	
批准/Approved	罗小春	

NO	A	B	C	D	E	F	序																				
1					Real Picture/实物图片或3D图 		6																				
2					Technical parameters/技术参数		5																				
3					<table border="1"> <tr><td>1</td><td>Rating/使用功率:2mA to 10mA 1-24V DC</td></tr> <tr><td>2</td><td>Cond Uction Mode/导通方式:Discontinuous conduction 非连续导通</td></tr> <tr><td>3</td><td>Contact Resistance/接触电阻:>10mΩ</td></tr> <tr><td>4</td><td>Insulation Resistance/绝缘电阻:100MΩ min.at 100DC MIN.</td></tr> <tr><td>5</td><td>Insulation Strength/绝缘强度:AC 500V 50Hz 1 MINUTE.</td></tr> <tr><td>6</td><td>Capacitance Conductivity/电容量-导通率:5pF max-95% min</td></tr> <tr><td>7</td><td>Sensitivity/敏感度:■高 □一般 □迟钝</td></tr> <tr><td>8</td><td>Trigger Angle/触发角度:□15度 □35度 □90度 ■全方位</td></tr> <tr><td>9</td><td>Vibration Frequency/震动频率:于2Hz为振频1秒2次来回</td></tr> <tr><td>10</td><td>Service Life/使用寿命:500, 000Cycles</td></tr> </table>		1	Rating/使用功率:2mA to 10mA 1-24V DC	2	Cond Uction Mode/导通方式:Discontinuous conduction 非连续导通	3	Contact Resistance/接触电阻:>10mΩ	4	Insulation Resistance/绝缘电阻:100MΩ min.at 100DC MIN.	5	Insulation Strength/绝缘强度:AC 500V 50Hz 1 MINUTE.	6	Capacitance Conductivity/电容量-导通率:5pF max-95% min	7	Sensitivity/敏感度:■高 □一般 □迟钝	8	Trigger Angle/触发角度:□15度 □35度 □90度 ■全方位	9	Vibration Frequency/震动频率:于2Hz为振频1秒2次来回	10	Service Life/使用寿命:500, 000Cycles	4
1	Rating/使用功率:2mA to 10mA 1-24V DC																										
2	Cond Uction Mode/导通方式:Discontinuous conduction 非连续导通																										
3	Contact Resistance/接触电阻:>10mΩ																										
4	Insulation Resistance/绝缘电阻:100MΩ min.at 100DC MIN.																										
5	Insulation Strength/绝缘强度:AC 500V 50Hz 1 MINUTE.																										
6	Capacitance Conductivity/电容量-导通率:5pF max-95% min																										
7	Sensitivity/敏感度:■高 □一般 □迟钝																										
8	Trigger Angle/触发角度:□15度 □35度 □90度 ■全方位																										
9	Vibration Frequency/震动频率:于2Hz为振频1秒2次来回																										
10	Service Life/使用寿命:500, 000Cycles																										
4					END FOOT SHAPE/端脚形状		3																				
5					<input type="checkbox"/> 直插式 DIP 180度 <input type="checkbox"/> 固定式 DIP 90焊接 <input checked="" type="checkbox"/> 贴片式 SMD 字面向上平贴		2																				
6					Ball selection/滚珠选择 <input type="checkbox"/> F 扁珠 Flat bead <input checked="" type="checkbox"/> B 圆珠 Ball Ball selection/电镀选择 <input checked="" type="checkbox"/> Ag 镀银 Ag PLATED <input type="checkbox"/> Au 镀金 Au PLATED Sensitivity Selection/敏感度选择 <input checked="" type="checkbox"/> HI 高敏感度 High sensitivity <input type="checkbox"/> IN 中敏感度 Medium sensitivity <input type="checkbox"/> SO 低敏感度 Low sensitivity Color Selection/颜色选择 <input type="checkbox"/> BLACK/黑色 <input type="checkbox"/> WHITE/白色 <input type="checkbox"/> RICE WHITE/米黄、米白色		1																				
					TOLERANCE/公差范围表																						
					<table border="1"> <tr> <td>L ≤ 5</td> <td>±0.1mm</td> <td>±0.1°</td> </tr> <tr> <td>L ≥ 5</td> <td>±0.2mm</td> <td></td> </tr> </table>		L ≤ 5	±0.1mm	±0.1°	L ≥ 5	±0.2mm																
L ≤ 5	±0.1mm	±0.1°																									
L ≥ 5	±0.2mm																										
序	F	E	D	C	B	A	NO																				

放位引导图

PCB板焊位图

公司名称	韩下 深圳市韩下电子有限公司		7				
TITLE 品名:	Vibration Sensing Switch/震动感应开关	DWN. : 黄彬	6	Marking 字印	Colored silk screen printing 丝印	1	BLACK 黑色
NUMBER 编号:		CHKD. : 张伟	5	Internal Wiring 内部线	Copper Skin 铜皮	1	Ag PLATED 镀银
MODEL 型号:	HX 1210-0S-X160	APPD. : 罗小春	4	Solder End Pins 焊锡端	Copper Skin 铜皮	4	Ag PLATED 镀银
SCALE 比例:	3 : 1	DATE : 2019.03.16	3	Matrix 基体	PCB Polymer Material 高分子材料	1	NATURAL 原色
	UNIT 单位: mm/毫米		2	Ball drop 滚珠	Carbon Steel 碳钢		Ag PLATED 镀银
			1	Cover Plate 上下盖板	PHENOLIC LAMINATE 石碳酸层板	1	NATURAL 原色
			NO	PART NAME 零件名称	MATERIAL 物质材料	数量	FINISH 表面状态

NO	A	B	C	D	E	F	序
----	---	---	---	---	---	---	---

应用说明及功能描述

1	一、Function 功能: 1.Motion detecting. 运动触发检测。 2.Wake up function. 唤醒功能	功能描述: 该产品是一款全方位振动侦查、位移感知或运动唤醒的传感器，以其高灵敏度来感知外界环境的震动变化。不管如何贴在PCB板上，静止时，传感器一般处于接通状态，当发生震动或位移时，传感器会发生连续的高低电平变化。	6
---	--	--	---

2	二、Product application scenarios 产品应用场景: 1.Remote controller 遥控器 2.Automation device 自动化装置 3.GPS communication products GPS通信产品	应用场景: 消防报警系统、电动车智能防盗、遥控钥匙、行车记录仪、GPS导航、车载净化器、车载香熏器、胎压监测 (TPMS)、RFID、车灯自动感应系统及各种蓝牙数码产品、智能手表、手环、智能头盔、智能眼镜等智能穿戴设备、电烙铁、鞋灯、球灯、网球拍、暖手宝、电烫斗、电容笔、成人用品等产品的运动型触动式唤醒装置和各种需要检测小型震动、振动、倾斜感应、位移感知、运动感知的场景应用中。	5
---	--	---	---

3	4.Household appliances 家用电器 5.Car anti-theft equipment 汽车防盗设备		4
---	--	--	---

4	三、Product characteristics 产品特性: 1.This product is a miniature ball type omnidirectional signal triggered induction detection switch component, without the need to distinguish between electrode direction and positive and negative directions. 该产品为微小型滚珠式全方位信号触发感应侦查开关元件，无需区别电极方向及正反面向。 2.As the product is a mechanical vibration sensing element, it is in an ON or OFF state at any azimuth angle. When vibration is sensed, the internal components shake, generating alternating ON/OFF pulse signals, thereby triggering the circuit. (Signal form/trigger probability tip is explained as follows) 因产品为机械式震动传感元件，在任何方位角度是处于ON或者OFF状态，当感应到震动时，内部件抖动，产生ON/OFF交替的脉冲信号，从而触发电路。（信号形式/触发概率尖如下说明）		3
---	--	--	---

5	3.SMT, tape and disc packaging improve production efficiency. The material is resistant to 190 degrees without deformation, and can decompose up to 390 degrees. It works normally in a 120 degree environment. 贴片编带盘装提高生产效率，材料为耐190度不变形，热分解可达390度，120度环境中正常工作。 4.Fully sealed packaging, reliable sealing performance, dustproof, waterproof, antioxidant, waterproof up to PI68 level. 全密封封装，密封性能可靠，可防尘、防水、抗氧化，防水达PI68级别。 5.Equipped with specially treated ball bearings and contact lines, it has good contact electrification and high sensitivity, and has a long service life. 内置特殊处理的滚珠和接触线路，有较好的接触通电性和较高的灵敏度，拥有较长的使用寿命。		2
---	--	--	---

6	特别提示: 该产品信号处理简单，电路设计容易，在使用与长期且不停连续震动场合中，建议开发时加上延时的设计；如震动力过大，建议选用光电感应开关更可靠。 水平放置时较为灵敏，垂直放置时较水平方向比底些，贴别适合PCB水平放置之焊接。 任意放置没有固定的闭合状态，全方位振动侦查、位移感知、运动唤醒，感应灵敏度高。 采用抽真空包装工艺内部与空气隔绝，耐湿气，避免与空气接触氧化失效。 产品应用于更高安全性及可靠性的耐久或特殊设备中，如生命维持装置、宇宙航空装置、防灾、地震侦测及特种安全性装置时，请特别说明，可配合开发及改善，对应提升更高工艺及选用更高档次的材料来配合，以适用于军工产品为发展理念。		1
---	---	--	---

TOLERANCE/公差范围表	
TOLBRANCB	ANGLB TOL
L ≤ 5 ±0.1mm	±0.1°
L ≥ 5 ±0.2mm	

序	F	E	D	C	B	A	NO			
公司名称		深圳市韩下电子有限公司		7						
				6						
				5						
				4						
TITLE 品名:	VIBRATION SWITCH/震动感应开关	DWN. :	黄彬	3						
NUMBER 编号:		CHKD. :	张伟	2						
MODEL 型号:	HX 1210-OS-X160	APPD. :	罗小春	1						
SCALE 比例:	3 : 1	UNIT 单位:	mm/毫米	DATE :	2019.03.16	NO	PART NAME 零件名称	MATERIAL 物质材料	数量	FINISH 表面状态

电路设计方式示意图

常用电路接线方式

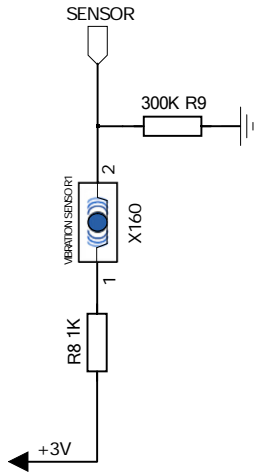

最省电接法

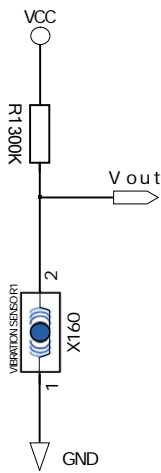

基本电路接法

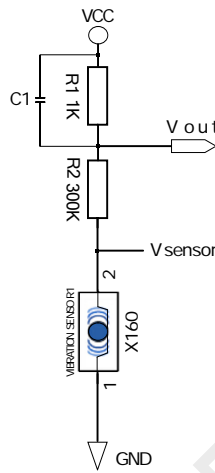

滤波电路接法

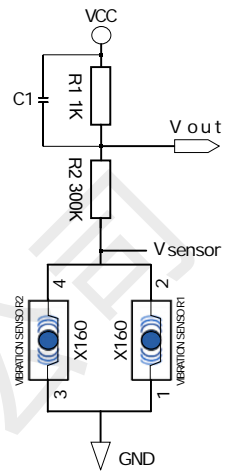

最可靠接法

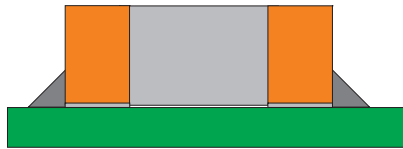

水平安装示意图

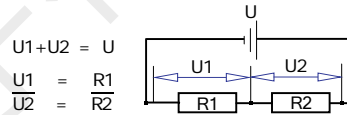

串联电路电压分配关系

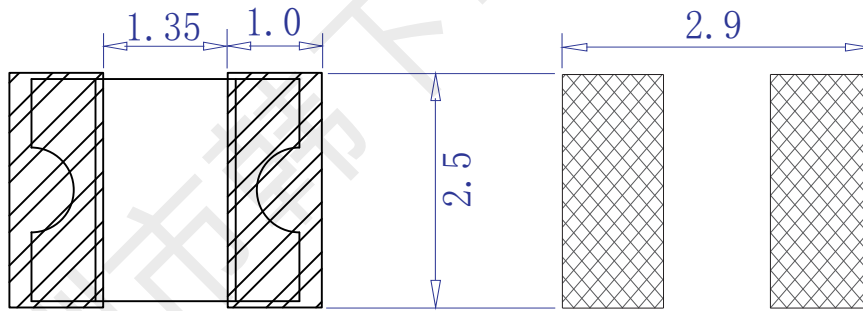

放位引导图

PCB板焊位图

特别提示：该产品在静止时不能保证100%处于接通状态，所以在设计软件时应该考虑信号由高到低和由低到高的过渡变化过程，可通过软件设置调节读取和捕捉所需要的灵敏度，常闭电流同样可以通过软件设置规避固定电平脉冲。

TOLERANCE/公差范围表

TOLBRANCB		ANGLB TOL
$L \leq 5$	$\pm 0.1\text{mm}$	$\pm 0.1^\circ$
$L \geq 5$	$\pm 0.2\text{mm}$	

序 F E D C B A NO

公司名 称	 深圳市韩下电子有限公司	7						
		6						
		5						
		4	TERMINAL 端子	BRASS STRIP 黄铜带C2680	4	Ag PLATED 镀银		
TITLE 品名:	VIBRATION SWITCH/震动感应开关	DWN. : 黄彬	3	BASE 底基	GLUE MATERIAL PA66胶料	1	BLACK 黑色	
NUMBER 编号:		CHKD. : 张伟	2	Ball drop 滚珠	Carbon Steel 碳钢	1	Ag PLATED 镀银	
MODEL 型号:	HX 1210-0S-X160	APPD. : 罗小春	1	COVER 盖子	GLUE MATERIAL PA66胶料	1	BLACK 黑色	
SCALE 比例:	3 : 1	UNIT 单位: mm/毫米	DATE : 2019.03.16	NO	PART NAME 零件名称	MATERIAL 物质材料	数量	FINISH 表面状态

震动触发方式示意图

Horizontal normally closed omnidirectional vibration sensing, 360 degree tilt sensing, there is an instantaneous slight disconnection phenomenon when standing at 90 degrees and 180

水平常闭全方位振动感应 360度倾斜感应 直立90度与180度时，有瞬间轻微断开的现象。

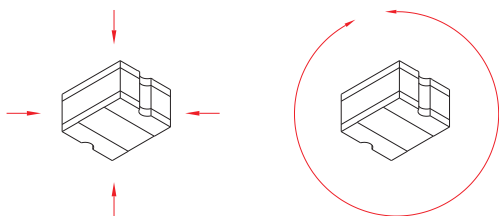

触发角度分布图



电路波形图

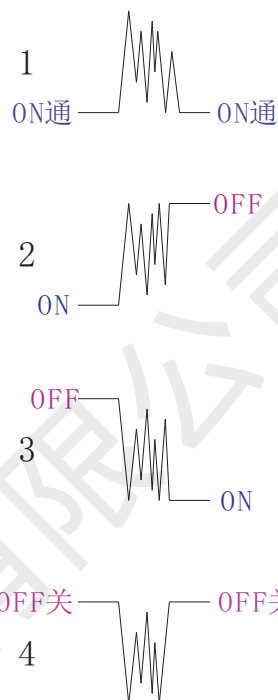

传感器信号形式: 4种表现

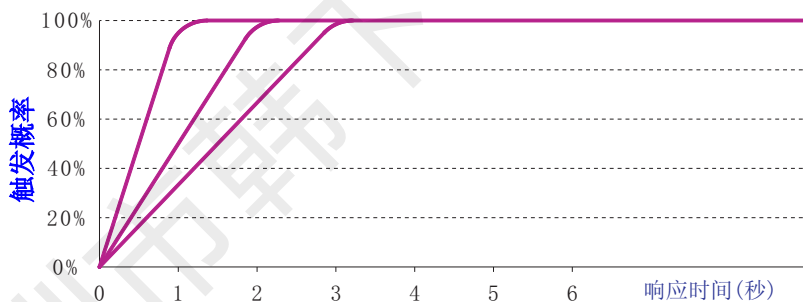

10-200Hz随机振动，振幅大于1mm。

多轴震动示意图

应用说明：传感器与一个上拉电阻组成检测电路，电阻的取值由检测电路的输入阻抗所决定，如果直接输入到单片机，可将单片机的端口设置成“输入型”，其上拉电阻在10K到10M范围内，为减少静态电流损耗，其上拉电阻可尽量选择大一些。当发生震动或位移时，单片机可通过检测到的高低电平变化来触发唤醒，并可通过软件设置延时来调节灵敏度。

TOLERANCE/公差范围表	
TOLBRANC	ANGLB TOL
L ≤ 5 ±0.1mm	±0.1°
L ≥ 5 ±0.2mm	

序	F	E	D	C	B	A	NO
公司名	深圳市韩下电子有限公司			7			
				6			
				5			
				4	TERMINAL 端子	BRASS STRIP 黄铜带C2680	4 Ag PLATED 镀银
TITLE 品名:	VIBRATION SWITCH/震动感应开关		DWN. : 黄彬	3	BASE 底基	GLUE MATERIAL PA66胶料	1 BLACK 黑色
NUMBER 编号:			CHKD. : 张伟	2	Ball drop 滚珠	Carbon Steel 碳钢	1 Ag PLATED 镀银
MODEL 型号:	HX 1210-0S-X160		APPD. : 罗小春	1	COVER 盖子	GLUE MATERIAL PA66胶料	1 BLACK 黑色
SCALE 比例:	3 : 1	UNIT 单位: mm/毫米	DATE : 2019.03.16	NO	PART NAME 零件名称	MATERIAL 物质材料	数量 FINISH 表面状态

出货包装封箱方式示意图

一、适用范围：

适用该OS-H160的绕带封装要求。

二、封装材料：

适用该OS-H160货品的绕带封装的材料使用要求。

三、包装数量：

- A.小盘小箱： 2000PCS B.小盘大箱： 10000PCS**
- C.大盘小箱： 8000PCS D.大盘中箱： 16000PCS**
- F.大盘大箱： 40000PCS**

四、封箱尺寸示意图：

卷盘类型：

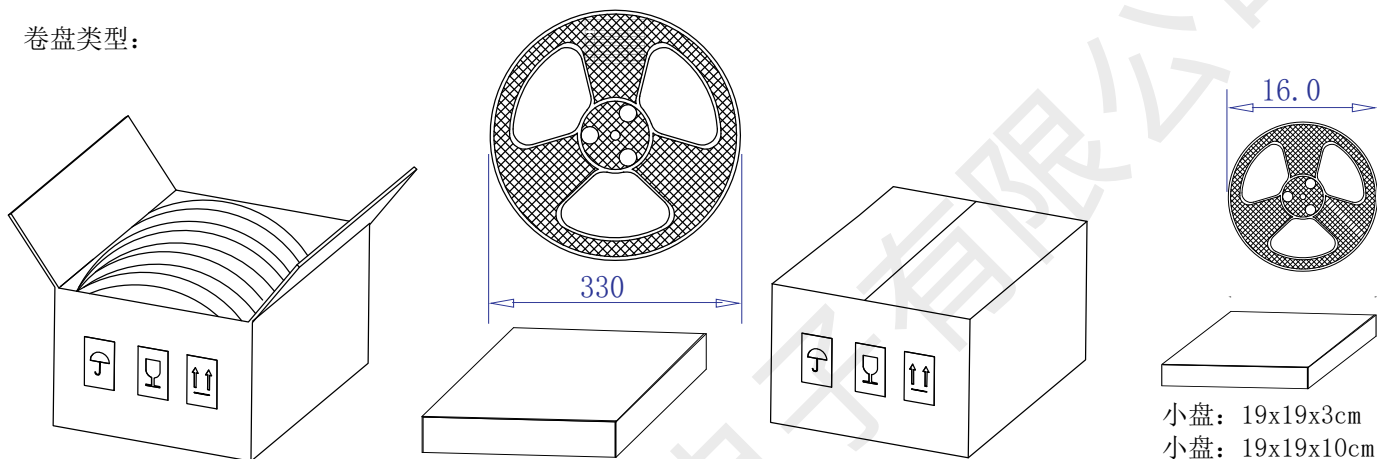

袋盒类型：

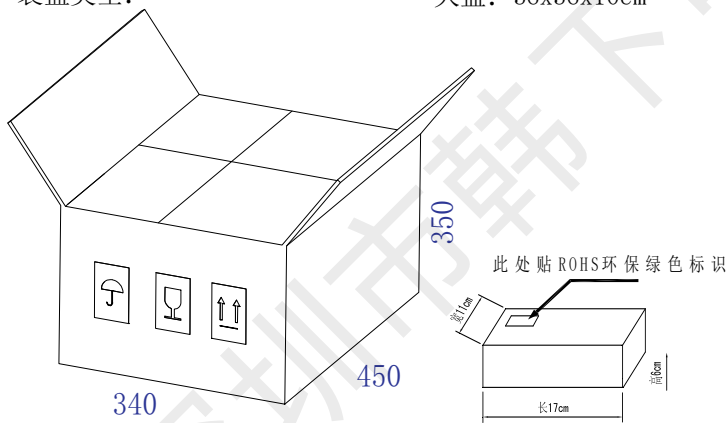

检测说明：本产品严格实行100%全检出货，编带前已经全自动机器测试过，为安全产品，当传感器处于静止状态时，不保证100%导通，但有轻微震动或位移时能输出脉冲信号，则判断为传感器功能正常。

TOLERANCE/公差范围表	
TOLBRANCB	ANGLB TOL
L ≤ 5	±0.1mm
L ≥ 5	±0.2mm
	±0.1°

箱别	盘数	总量	材料说明
小盘小箱	2盘	4000PCS	硬纸盒
小盘大箱	5盒	10000PCS	硬纸箱
大盘小箱	1盘	8000PCS	硬纸盒
大盘中箱	2盘	16000PCS	硬纸盒
大盘大箱	5盒	40000PCS	硬纸箱
封箱胶带	任用	任用	环保胶带

序	F	E	D	C	B	A	NO
公司名称	深圳市韩下电子有限公司			7			
TITLE 品名:	VIBRATION SWITCH/震动感应开关	DWN. :	黄彬	3			
NUMBER 编号:		CHKD. :	张伟	2			
MODEL 型号:	HX 1210-OS-X160	APPD. :	罗小春	1			
SCALE 比例:	3 : 1	UNIT 单位:	mm/毫米	DATE :	2019. 03. 16	NO	
	PART NAME 零件名称	MATERIAL 物质材料	数量	FINISH 表面状态			

Product Specification 产品规格书

Products Designation 产品系列	Vibration Sensing Switch 震动开关/滚珠开关/震动感应器	Module No. 产品型号	HX 1210-0S-X160		
Rated Current 额定电流	1uA to 10mA 1-24V DC	Tming 切换类型	SHORTING 常闭短路型	功能作用 接通方式	全方位非连续导通 滚珠震动触发
Welding Requirements/焊接要求	过回流炉焊时, 注意控好260℃最高峰值3秒内焊好, 温度太高会改变材料特性, 有可能会降低敏感度。				

一. General Characteristics 一般特性

Usage 产品用途	This specification is described (VIBRATION SWITCH) the mechanical properties and electrical characteristics, and the (SWITCH) is mainly used for electronic device as (small) current connection or signal conversion. 本规格书是描述(感应开关)之机械特性与电气特性, 而该(开关)主要是用来作为(小)型电流连接或讯号转换之电子装置。
Work Temperature 工作温度	Temperature of -10~60 °C within the work environment. 温度-10~+60℃ 环境内工作。
Storage Temperature 保存温度	Temperature -20~ +70 °C environment preservation. 温度-20~+85℃ 环境内保存。
Standard Atmosphere Conditions 测试标准状态	Unless otherwise specified, the standard range or atmospheric conditions for making measurements and tests are as follows: 1. Ambient temperature: 5°C-35°C 2. Relative humidity: 45-85% 3. Air pressure: 86kpa to 106kpa 在没有指定的情况下测试温度, 湿度, 气压: 1. 温度为: 5°C-35°C 2. 湿度为: 45-85%. 3. 大气压强为: 86-106帕。

二. Appearance & Dimension Requirement 产品外观及尺寸要求

2.1	Test product shape structure is compact, no coordination is not good. 测试品外形结构紧凑, 无配合不良。
2.2	Test plastic parts without shrinkage, front, drop, spot, damage or deformation. 测试品塑胶部件无缩水、披锋、欠注、斑点、破损或变形现象。
2.3	Test pin and shell without oxidation, dirty, deformation, burr or plating. 测试品引脚和外壳无氧化、脏污、变形、毛刺或电镀不良。
2.4	Test pin and shell without oxidation, dirty, deformation, burr or plating. 测试品操作顺畅, 节奏感强, 无明显阻碍
2.5	The structure and size of the test products refer to the product specification drawing, and the tolerance standard is implemented according to the GB1804-M precision. 测试品结构及尺寸参见产品规格图纸, 公差标准按GB1804-m级精度施行。

ITEM 项目	Test Conditions 测试条件	Equipment 测试设备	Testing Requirements 测试要求
------------	-------------------------	-------------------	------------------------------

三. Electrical Characteristics 电气性能规格

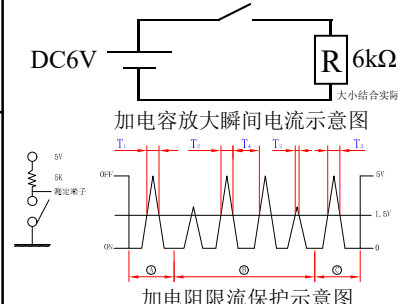
3.1	Contact Resistance 接触电阻	Voltage degradation method was used to measure 1 KHz ± 200 Hz (20mV Max, 100mA Max). 以1KHz±200Hz (20 mV Max, 50 mA Max) 采用电压降解法测	Low Resistance Meter 低电阻测试仪	 <p>DC6V</p> <p>加电容放大瞬间电流示意图</p> <p>30mΩ max.</p>
3.2	Insulation Resistance 绝缘电阻	Apply a voltage of DC 100V shall be applied for 1 min at which measurement be made: 1. Between terminals; 2. Between individual terminal and frame; 输入100V DC 电压1分钟, 按以下接触法测试: 1. 排脚相互之间; 2. 排脚与外壳之间; 3. 排脚与绝缘体之间。	Insulation Resistance Tester 绝缘测试仪	
3.3	Dielectric Strength 耐电强度	AC 500V rms (50-60HZ) for 1 min trip current 0.5mA 1. Between terminals; 2. Between individual terminal and frame. 输入AC 500V (50-60HZ 漏电流10mA) 电压, 1分钟感应电流为0.5mA, 按以下接触法测试: 1. 排脚相互之间; 2. 排脚与外壳之间。	Puncture Tester 耐压测试机	

100MΩ min.
No insulation damage and other anomalies, leakage current is 0.5mA
30毫欧以下。
100兆欧以上。
无绝缘破坏等异常, 漏电流为0.5mA.

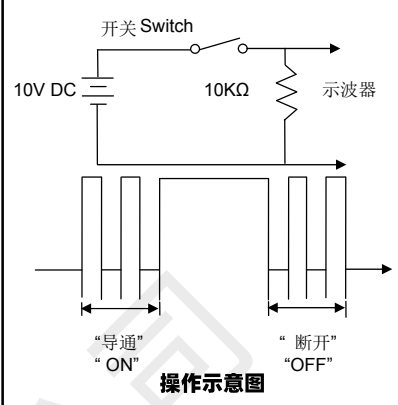
ITEM 项目	Test Conditions 测试条件	Equipment 测试设备	Testing Requirements 测试要求
3.4 Tremor sliding noise test 震颤滑动 噪声测试	<p>Test at a DC 5V 1mA load speed of 30mm/s: The tremor/pulsation noise voltage varies above 1.5V; Tremor (10ms in A and C fields) T1 and T3= less than 10ms; Sliding noise (field B) T2= less than 10ms; At least once T4=20ms or more; When the area below 1.5V between sliding noises is above 250us, it is other sliding noises.</p> <p>在DC 5V 1mA负荷下以30mm/s 的动作速度进行测试: 震颤/跳动噪声电压变动在1.5V以上; 震颤 (A、C领域各10ms) T1、T3=10ms以下; 滑动噪声 (B领域) T2=10ms以下; 至少要确保一次T4=20ms以上; 滑动噪声间1.5V以下的区域250us以上时, 为别的滑动噪声。</p>	<p>Sliding friction vibration noise test bed</p> <p>滑动摩擦振动 噪声试验台</p>	

四. Mechanical Characteristics 机械性能规格

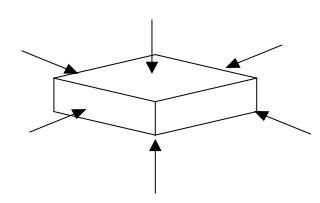
4.1	<p>Full travel</p> <p>行程</p>	<p>Vertical operation of the test product, measuring the top end to the working position of the maximum moving distance.</p> <p>垂直操作测试品,量测顶端到工作位置的最大移动距离。</p>	<p>PT Tester Vernier Caliper GBD1804-m PT治具游标卡尺</p>	<p>See the drawings 见图纸</p>
4.2	<p>Operating force</p> <p>操作力</p>	<p>Uniform static loads are applied to the working position along the operating direction at the end of the test product.</p> <p>在测试品末端沿操作方向均匀施加静载荷转换到动作位置。</p>	<p>Push-Pull Force Gauge</p> <p>推拉力计</p>	<p>See the drawings 见图纸</p>
4.3	<p>Terminal Strength</p> <p>端子强度</p>	<p>Apply 300gf motion test in any direction at the front of the test foot for 15 seconds.</p> <p>在测试品的排脚前端任意一个方向施加300克力移动测试,持续时间15秒。</p>	<p>Poise</p>	<p>The terminal is not cracked or loose and is satisfied with mechanical and electrical properties. 端子无裂开、松动等异常,满足于机械、电气性能。</p>
4.4	<p>Operating unit strength</p> <p>操作部强度</p>	<p>A static pressure load of 1N(102gf) for 15 seconds is required in all directions.</p> <p>各方向需经受住15秒1N(102gf)的静施压载荷。</p>	<p>砝码</p>	<p>The body is not seriously deformed and can be used normally 本体无严重变形,可正常使用</p>
4.5	<p>Loose operation part</p> <p>操作部松动</p>	<p>0.5N(51gf) static load was applied to the top of the operating part.</p> <p>向操作部顶端施加0.5N(51gf) 静载荷。</p>	<p>冲击试验机</p>	<p>无明显松动, 松动量控制在1mm以内</p>
4.6	<p>Shaking test</p> <p>摇晃试验</p>	<p>1.Shake amplitude: 1.5 mm 2.Shake frequency: 1 minute 10-55-10Hz 3.Shake method: X, Y, Z three-axis rotation motion 4.Shake time: 3 hour in each of the X, Y, and Z axes</p> <p>1.摇晃幅度: 1.5mm 2.摇晃频率: 1分钟10-55-10Hz 3.摇晃方法: X、Y、Z 三轴轮换运动 4.摇晃时长: X、Y、Z 三轴每个方向3小时</p>	<p>Vibration tester</p> <p>振动测试仪</p>	 <p>No appearance or functional damage. Electrical and mechanical</p>
4.7	<p>Vibration testing</p> <p>冲击测试</p>	<p>1. Installation type: After finished product 2. Acceleration: 490m/s 3. Experimental direction: All touchable surfaces 4. Number of shocks: 3 times in each direction, a total of 18 t.</p> <p>1.安装类型: 成品后 2.加速度: 490m/s 3.实验方向: 所有可触接触面 4.冲击次数: 每个方向3次, 共18次。</p>	<p>GBT 229-2007 Impact testing machine</p> <p>冲击试验机</p>	<p>There should be no appearance or functional damage, and the electrical and mechanical properties should meet the requirements of various indicators.</p> <p>无外观及功能损坏, 电气和机械性能应符合各项指标要求。</p>

ITEM 项目	Test Conditions 测试条件	Equipment 测试设备	Testing Requirements 测试要求
4.8 破坏测试	1. Drop mode: free fall; 2. Experimental height: 3 meters 3. Destruction method: Renyifangxiang, 1 t in each direction. 1. 跌落方式: 自由落体; 2. 跌落高度: 3米 3. 破坏方式: 任意方向, 每个方向1次。	GB/T14153 Impact tester 跌落试验机	no abnormal operation, electrical performance should meet the requirements of 3.3. 表面无变形且操作无异常, 电气性能应符合第3.3的要求
4.9 机械寿命	1. Endurance without loading: Operation tests performed 5,000,000 tests at a speed of 15-20 times per minute without load; 2. Endurance with loading: Operation tests performed 500,000 tests at a speed of 15-20 times per minute under load; 1. 无负荷: 操作测试品在无负荷条件下以每分钟15-20回的速度进行5,000,000次的测试; 2. 负荷: 操作测试品在负荷条件下以每分钟15-20回的速度进行500,000次的测试。	 Life Tester 寿命试验机	1. Contact resistance: 10mΩ max. 2. Insulation Resistance: 100MΩ min. 3. Dielectric Strength: AC 100V for 1 mi 4. Operating force: ±30% initial valve. 5. Without damage to parts arcing or breakdown etc. 1. 接触电阻10毫欧以下; 2. 绝缘电阻100兆欧以上; 3. 耐电压AC 100V 1分钟; 4. 动作力变化范围初始值±30%; 5. 测试后表面无损伤, 并且满足机械性能。

五. Durability Test 耐久性测试

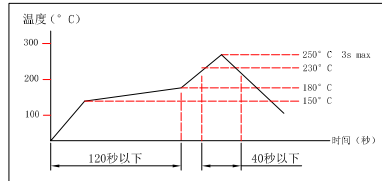
5.1 可焊性试验	Under the conditions of test using solder H63A(JIS Z 3282), solder(JIS K 5902), 25 % Rosin ratio of 75 % methanol colorless transparent solution, the test end is immersed in the solder pool at a temperature of 230 ± 5 °C, The welding time is 3 ± 0.5 seconds. 在使用焊料H63A(JIS Z 3282), 焊剂(JIS K 5902), 25%的松香配比75%的甲醇无色透明溶液的测试条件下, 测试品端子浸入焊锡池, 温度230±5°C, 焊接时间3±0.5秒内完成。		
5.2 耐焊性试验	1. Reflow welding method The surface temperature of the terminal at the welding point is controlled at 260 ± 5 °C, and the welding time of the furnace is 3 ± 0.5 seconds; 2. Automatic welding The PCB board with a welding time of 3 ± 0.5 seconds of 1.6 mm thickness will complete the welding temperature control of 280 ± 10 °C; 3. Manual welding The welding temperature must be controlled at 350 ± 10 °C and the time is 3 ± 0.5 seconds, but abnormal pressure can not be applied to the foot. 1. 使用回流焊法时, 焊接处端子表面温度控制在260±5°C, 过炉焊接的时间3±0.5秒; 2. 使用自动焊接法时, 焊接时间3±0.5秒内在1.6mm厚度的PCB板上将焊接温度控制280±10°C完成操作; 3. 使用手工焊接法时, 焊接温度需控制在350±10°C, 时间为3±0.5秒, 但不能在排脚上施加异常压力。	Solder Stove 控温锡炉	Some 85% of immersion the surface will be covered with solder. Without deformation of case or excessive looseness of teminals electrical characteristics shall be satisfied. Non-sealed structure products, please eliminate the use of flux, non-patch non-high temperature recommended manual welding operation. 浸入的部分85%以上将被锡覆盖; 本体无变形, 能满足于机械、电气性能; 非密封结构产品, 请杜绝使用助焊剂, 非贴片非耐高温建议手工焊接操作。

ITEM 项目	Test Conditions 测试条件	Equipment 测试设备	Testing Requirements 测试要求
5.3 Humidity Test 耐湿试验	The test product was placed in an environment with a temperature of $60 \pm 3^\circ\text{C}$ and a relative temperature of 90-95%. After 48 hours, the test was carried out after a normal environment was moved for 1 hour. 将测试品放置在温度为 $60\pm 3^\circ\text{C}$ ，相对温度为90-95%的环境中48小时后，再移置正常环境下1小时后进行测试。	Temperature & Humidity Tester Chamber 恒温恒湿箱	<p>温度(°C)</p> <p>1 cycle</p> <p>A</p> <p>0°C</p> <p>B</p> <p>时间(hour)</p> <p>C D E F</p> <p>A: $+85 \pm 3^\circ\text{C}$ B: $-25 \pm 3^\circ\text{C}$ C: 2 小时 D: 1 小时 E: 2 小时 F: 1 小时 周 期: 5 次 Cycling: Five cycles</p> <p>After testing:</p> <ol style="list-style-type: none"> Contact resistance 10mΩ max. Insulation resistance 100MΩ min. The electrical performance should meet all requirements; Sensitivity changes within ± 10; Good appearance of the components, no Rust, cracks, plating poor phenomenon. <p>测试后:</p> <ol style="list-style-type: none"> 接触电阻10毫欧以下; 绝缘电阻100兆欧以上; 电气性能应符合各项要求; 敏感度变化在± 10以内; 外观各部件良好，金属件上无严重的腐蚀斑点、无生锈、裂纹、电镀层脱落等不良现象。
5.4 Heat Test 耐热试验	The test product was placed at a temperature of $85 \pm 3^\circ\text{C}$ for 48 hours and then moved to normal room temperature for 1 hour. 将测试品放置在温度为 $85\pm 3^\circ\text{C}$ 中48小时后，再移置正常室温下1小时后进行测试。	High & Low Tester Chamber 高低温试验箱	
5.5 Cold Test 耐冷试验	After placing the test product in a temperature of $-40 \pm 3^\circ\text{C}$ for 48 hours, it was moved to room temperature and often wet for 1 hour to test. 将测试品放置在温度为 $-40\pm 3^\circ\text{C}$ 环境中48小时后，再移置于常温常湿下1小时后进行测试。	High & Low Tester Chamber 高低温试验箱	
5.6 Satl Mist Test 盐雾实验	The test product is measured after the following experiments: 1. Temperature : $35 \pm 5^\circ\text{C}$ 2. Salt solution: $5 \pm 1\%$ (Solids by mass) 3. Test time: copper, stainless steel 24 hours / iron 12 hours 4. After immersing ,salt deposit shall be removed by running water. 测试品在下述实验后测量: 1. 温度: $35 \pm 5^\circ\text{C}$ 2. 盐溶液浓度: $5 \pm 1\%$ (质量百分比) 3. 试验时间: 铜、不锈钢 24小时 / 铁 12小时 2. 酸、碱液浓度: $5 \pm 1\%$	Water fog testing machine 水雾试验机	
5.7 Acid resistance alkalization test 耐酸碱化实验	The test product is measured after the following experiments: 1. Temperature : $40 \pm 2^\circ\text{C}$ 2. Acids, lye concentration: $1 \pm 0.2 \text{ PPM}$ 3. Test time: copper, stainless steel 48 hours / iron 24 hours 4. After the test, flush the acid and alkali sediments with water. 测试品在下述实验后测量: 1. 温度: $40 \pm 2^\circ\text{C}$ 2. 酸、碱液浓度: $1 \pm 0.2 \text{ PPM}$ 3. 试验时间: 铜、不锈钢 48小时 / 铁 24小时 4. 试验后,将酸、碱沉积物用水冲掉。	Water fog testing machine 水雾试验机	

六. Post-test performance 测试后性能

Contact Resistance	接触电阻	20mΩ 以下
Insulation Ressistance	绝缘电阻	120MΩ
DielectricStrength	耐电压	AC 500V 1分钟
Sensitivity	敏感度	下降10%

七. Sensitivity selection/敏感度选择

See the drawings

<input checked="" type="checkbox"/>	HI	高敏感度 High sensitivity
<input type="checkbox"/>	IN	中敏感度 Medium sensitivity
<input type="checkbox"/>	SO	低敏感度 Low sensitivity

八. Functional differences 功能差别

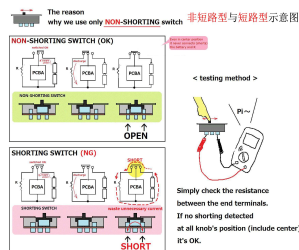

Diagram of difference between SHORTING and NON-SHORTING?

Short circuit, normally closed type, with the surface LED light on and constantly consuming electrical energy; Non short-circuit, normally open type, with the Short circuit, normally closed type, with the surface LED light on and constantly surface LED light off and no power consumption; Regardless of electrical energy issues, it can be set as normally closed and normally open in the IC microcontroller for mutual compatibility.

短路与非短路的区别?

短路，为常闭型，表视LED灯是亮着，始终消耗电能；

非短路，为常开型，表视LED灯是灭着，不耗电；

不考虑电能问题可以在IC单片机中设置为常闭常开相互兼容。

九. Material application reference and selection 材料应用参考与选择 (□和■选折项)

NO.	PART NAME 名称	MATERIAL 材料	FINISH 表面状态
1 <input type="checkbox"/>	BRADD STRIP 接触码片	BRADD STRIP 磷铜带 C5210	Ag PLATED 镀银
2 <input type="checkbox"/>	CONTACT PLATE 接触桥片/弹片	BRADD STRIP 磷铜带 C5210	Ag PLATED 镀银
3 <input type="checkbox"/>	BASE 底板/电子板	PHENOLIC LAMINATE 石碳酸层板 石碳酸层板	NATURAL 原色
4 <input type="checkbox"/>	BASE 底板 过SCCP特殊材料	Short chain chlorinated paraffin insulation board (SCCPs) 短链氯化石蜡绝缘板	NATURAL 原色
5 <input type="checkbox"/>	TERMINAL 端子/端脚	BRASS STRIP 黄铜带 C2680	Ag PLATED 镀银
6 <input type="checkbox"/>	FRAME 铁壳	FERRIC STRIP 铁带	Ni PLATED 电叻
7 <input type="checkbox"/>	KNOB 塑料柄/推柄/胶头	POM/PA 赛钢/尼绒	BLACK/WHITE 黑色/白色
8 <input type="checkbox"/>	SPRING 弹弓/接触弹弓	SUS WIRE 钢丝	NATURAL/Gold PLATED 原色/镀金
9 <input type="checkbox"/>	Shrapne 弹片/滑片	BRADD STRIP 黄铜带 H62	NATURAL 原色
10 <input type="checkbox"/>	Ball drop 波珠/滚珠	Carbon Steel 碳钢	NATURAL 原色
11 <input type="checkbox"/>	FIXING GLUE 固定胶	EPOXY RESIN 环氧树脂	BLACK 黑色
12 <input type="checkbox"/>	SEAL CARTRIDGE 密封套	HEAT SHRINKABLE TUBE 热缩管	BLACK 黑色
13 <input type="checkbox"/>	TERMINAL 端子(四方针)	Copper wire 铜线	GILDING PLATED 镀金
14 <input type="checkbox"/>	RUBBER COVER 胶盖	GLUE MATERIAL 胶料	BLUE/BLACK 深蓝色/黑色
15 <input type="checkbox"/>	SEAL CARTRIDGE 密封套	Copper Sleeve 铜套	Ni PLATED 电叻
16 <input type="checkbox"/>	OUTERMOST SHELL 外壳	BRADD STRIP 黄铜带 H62	Ag PLATED 镀银
17 <input type="checkbox"/>	COVER 盖子	STAINLESS STEEL 不锈钢	Ni PLATED 电叻
18 <input type="checkbox"/>	Cover plate 盖板	FERRIC STRIP 铁带	Ni PLATED 电叻
19 <input type="checkbox"/>	WHITE BASE 底基/基座	GLUE MATERIAL 胶料	BLACK 黑色
20 <input type="checkbox"/>	Waterproof membrane 防水膜	Imported silicon film 进口硅胶片	BLACK 黑色
21 <input type="checkbox"/>	Waterproof membrane 防水膜	Golden finger waterproof membrane 进口金手指防水膜	YELLOW 黄色
22 <input type="checkbox"/>			
23 <input type="checkbox"/>			
24 <input type="checkbox"/>			

Material application and structure analysis diagram 材料应用及结构分析图

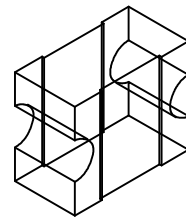
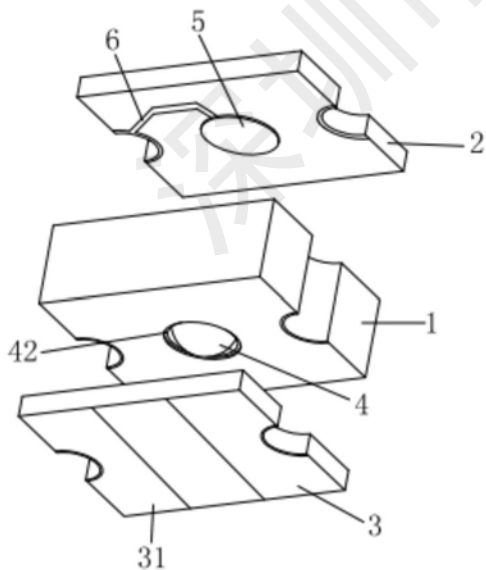



九. MATTERS NEEDING ATTENTION 注意事项

- 9.1 The article is not sealed structure, can not be cleaned, not anti-fog, pay attention to the correct use of flux during the welding process, flux boiling may directly penetrate into the gap, which leads to undesirable.
物品非密封结构, 不可清洗, 不防雾气的, 实施焊接过程中注意正确使用助焊剂, 助焊剂受热沸腾后可能直接渗入到缝隙中, 连带导致不良。
- 9.2 During welding, if the body and terminals are placed under load, deformation may occur, resulting in performance deterioration and affecting action and function. Please pay special attention to avoid this.
焊接时, 如对本体与端子施加荷重, 可能会产生变形, 导致性能恶化, 影响动作及功能, 请特别注意避免。
- 9.3 Thermal stress causes warpage changes in PCB circuit, which will directly affect the characteristics. Please understand the actual requirements in the welding conditions in advance.
热应力导致PCB电路版的翘曲变化, 会直接影响特性, 请事先充分了解焊接条件中的实际要求。
- 9.4 In case of multiple welding, please carry out the next operation after the first welding is restored to normal temperature. Continuous heating may cause deformation, loosening of terminals, shedding and reduction of electrical characteristics, etc., so try to avoid secondary welding.
进行多次焊接时, 请在第一次焊接恢复到常温后再进行下步操作, 连续加热可能产生变形、端子松动、脱落及电气特性降低等现象, 尽量避免二次焊接。
- 9.5 When drawing PCB board for circuit design and circuit design configuration, please consider the impact of vibration and pulsation on the body.
在对PCB板画图做回路设计及电路设计配置时, 请考虑震颤及跳动对本体的影响。
- 9.6 When starting the electrical characteristic parameter setting, it is recommended to take the middle value, such as current and voltage setting on the body.
启动电气特性参数设定时, 建议取中间值, 如电流及电压设定。
- 9.7 In order to improve the reliability, we hope to fully read the content and parameters of this specification before the actual use, which helps to ensure the quality and safety of the product when using. Understanding its characteristics is very important for the product itself, which can reduce the defect rate.
为提高可靠性, 望在实际使用前充分阅读本规格书内容及参数, 有助于确保使用时产品的品质安全, 了解其特性对产品本身很重要, 可以降低不良率;
- 9.8 Save method:
A. Please keep them under normal conditions and do not recommend excessive hoarding for periods exceeding six months. It is recommended that they be put into use after re-inspection;
B. Articles under normal conditions, 5-35 °C at room temperature, often wet 45-85 % RH, protected from direct sunlight, and not producing corrosive gases and liquids;
C. After opening before use, be sure to do a good job of sealing, ensure the partition with external gas, take out the desiccant in advance, which will accelerate the oxidation process, shorten the storage time accordingly, and affect the solderability.
保存方法:
A. 请在常开的状态下保存, 并尽快使用, 不建议过分囤积, 保存期限超过6个月, 建议复检后再投入使用;
B. 物品在常规状态下, 常温5-35°C, 常湿45-85%RH, 不受日光直接照射, 不产生腐蚀性气体和液体的地方保存;
C. 使用前提前开封后, 一定要做好密封, 确保与外气隔断, 事先拿出干燥剂, 会加速氧化的过程, 相应缩短保存时间, 影响可焊性。