

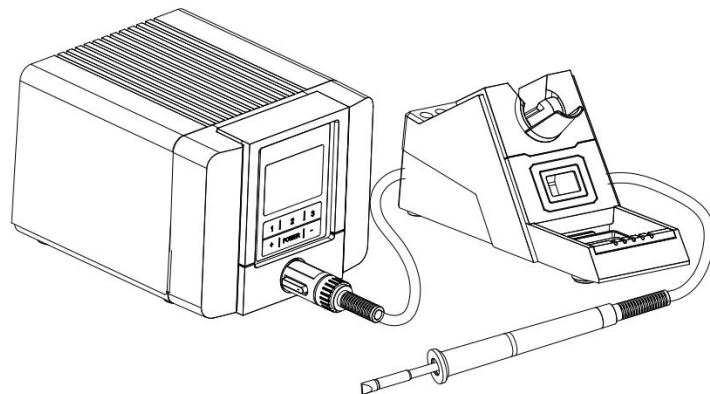

QUICK TS1200 Soldering Station

Instruction Manual



Thank you for purchasing our products. Please keep the instruction manual properly for future reference.

Contents

| | |
|---|----|
| 1. Safety Instructions..... | 1 |
| 2. Overview..... | 2 |
| 3. Product Characteristics..... | 2 |
| 4. Product Specifications..... | 3 |
| 5. Product Specifications..... | 4 |
| 5.1. Dimensions..... | 4 |
| 5.2. Part Descriptions..... | 4 |
| 5.3. Key Descriptions..... | 5 |
| 5.4. Function Descriptions of the Main Interface..... | 6 |
| 6. Use of Holder and Sponge..... | 7 |
| 7. Connection..... | 7 |
| 8. Turn On/Off..... | 7 |
| 9. Temperature Settings..... | 7 |
| 10. Menu Settings..... | 8 |
| 10.1. Temperature Parameter Settings..... | 8 |
| 10.2. Temperature Unit Settings..... | 9 |
| 10.3. Sleep Time Settings..... | 9 |
| 10.4. Close Time Settings..... | 10 |
| 10.5. Alarm Temperature Settings..... | 10 |
| 10.6. Password Settings..... | 11 |
| 10.7. ESD Function Settings..... | 12 |
| 10.8. Key Tone Settings..... | 12 |
| 10.9. Address Settings..... | 12 |
| 10.10. Language Settings..... | 13 |
| 11. Temperature Calibration..... | 13 |
| 12. Maintenance of Tips..... | 14 |
| 13. Selection of Tips..... | 15 |
| 14. Troubleshooting..... | 15 |
| 15. List of Tips..... | 16 |

1. Safety Instructions



CAUTION

- During the installation and use of this product, all electrical safety regulations of the country and regions must be strictly observed.
- The power supply must be disconnected when disassembling the product. Do not operate with power on.
- If the product does not work properly, please contact the supplier or our company, and do not disassemble or change the product in any way. We are not responsible for any problems caused by unauthorized maintenance or modification.



WARNING

- The product should be used away from places where there is magnetic interference.
- Don't install the product in a place where the surface is easy to shake or be impacted, as it may damage the product.
- Don't install the product in places where it may be exposed to rain or moisture.
- Don't use in flammable and explosive environments.
- After using the soldering station, the tip temperature will be quite high, which is easy to burn operators and may cause dangerous accidents.
- Power supply should be turned off during breaks or after work.
- Don't knock workbench with the soldering pencil to remove residual flux, which may seriously damage the soldering pencil.
- When the soldering pencil is not in use, please turn off the power to prolong its life.
- Please unplug the power cord when the product is not used for a long time.

2. Overview

This product is an intelligent lead-free soldering station. The soldering station adopts LCD liquid crystal display and touch buttons, which is more comfortable to use. Digital calibration mode, fast and convenient. Accurate and sensitive temperature sensing, fast heating and temperature recovery, it is an ideal tool for lead-free soldering.

3. Product Characteristics

- The process parameters of the three channels can be preset, which is more practical.
- With temperature alarm function, °C and °F interchangeable.
- The sensor is placed in front to monitor the tip temperature in real time, ensuring rapid temperature recovery.
- The tip (integrated with the heater) is plug-in design, which is easy to replace.
- With online communication function.
- Anti static design, with ESD detection function.

4. Product Specifications

| | |
|--------------------------|-------------------------|
| Model | TS1200 |
| Display | LCD |
| Power consumption | 120W |
| Voltage | AC 220V |
| Temperature range | 200°C~420°C/392°F~788°F |
| Temperature stability | ±2°C (no load) |
| Ambient temperature | 40°C |
| Tip to ground resistance | <2mV |
| Tip to ground potential | <2Ω |
| Dimensions (W×H×D) | 137*169*116mm |
| Weight | About 2.7kg |

5. Product Specifications

5. 1. Dimensions

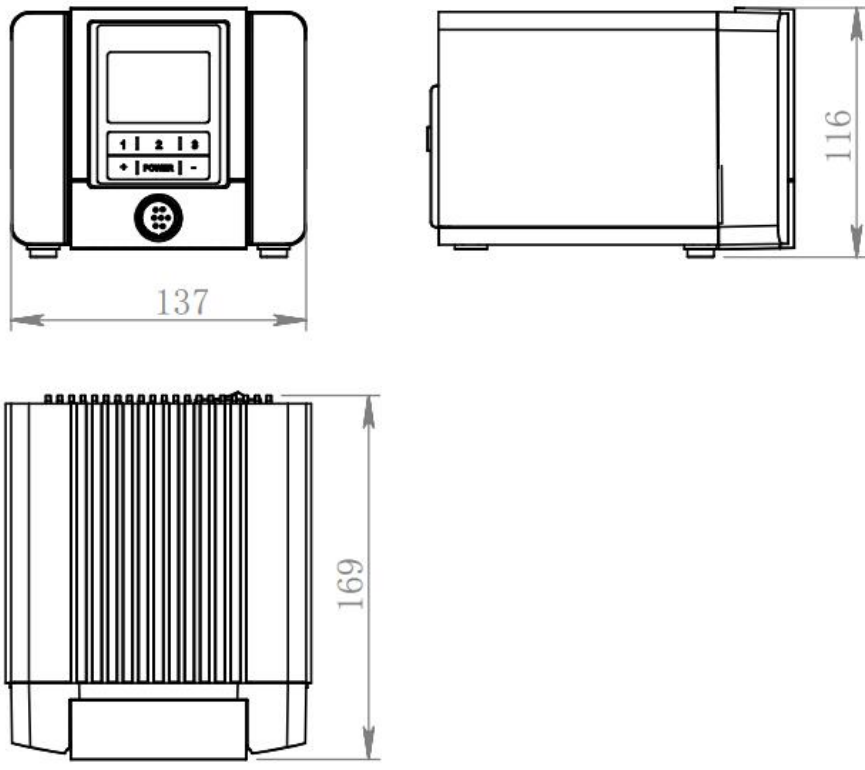

Unit: mm

5. 2. Part Descriptions

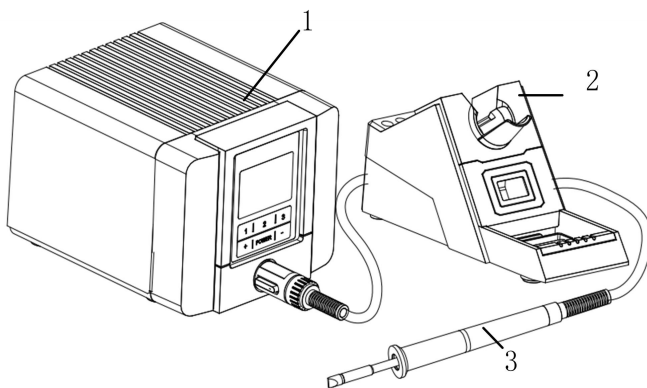









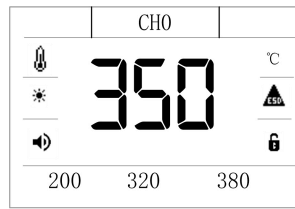

| NO. | Part Descriptions |
|-----|-------------------|
| 1 | Main unit |
| 2 | Holder |
| 3 | Soldering pencil |

5. 3. Key Descriptions

| Key | Function Descriptions |
|-------|---|
| 1/2/3 | <ol style="list-style-type: none">1. Press on the main interface to switch between CH1, CH2 and CH32. Press “2” and “3” keys at the same time on the main interface to enter the menu setting interface. Press “1 “and “3” keys at the same time to enter the temperature calibration interface3. Press “1” key on the menu setting interface to turn the page, and press“2” key to save,and“3” key to return |
| + | <ol style="list-style-type: none">1.Main interface: temperature up2.Setting interface: page down |
| - | <ol style="list-style-type: none">1. Main interface: temperature down2. Setting interface: page up |

5. 4. Function Descriptions of the Main Interface



| Symbol | Description | Symbols | Description |
|---|---|---|---------------------------|
| CH0 | Temporary channel |  | Red: anti-static alarm |
|  | Heating state | °C/°F | °C/°F interchangeable |
| 1  2  3  | 1. Indicates the heating state 2. Indicates the set temperature is reached 3. Indicates the cooling state |  | Temperature setting state |
|  | Buzzer on |  | Buzzer off |
|  | No password lock |  | Password lock |

6. Use of Holder and Sponge

- 1) Wet the cleaning sponge and then squeeze it dry.
- 2) Place the sponge into the groove of the holder base.
- 3) In the process of use, if the sponge becomes dry, please add water appropriately.

7. Connection

- 1) Insert the seven-core plug at the other end of the soldering pencil into the seven-core socket on the main unit (pay attention to the insertion position of the plug), and place the soldering pencil in the holder.
- 2) Insert the power plug of the soldering station into the power socket.
- 3) Insert one end of the grounding core into the grounding jack of the soldering station, and connect one end to anti-static ground.

8. Turn On/Off

Switch on/off, which can be divided into hard switch and soft switch.

- 1) Hard switch on / off: The power switch on the back of the main unit can realize hard switching.
- 2) Soft switch on / off: After the power switch is powered on, it can be turned on or off by long pressing the POWER key for 2 seconds.

9. Temperature Settings

Note:

- 1) When setting the soldering station temperature, make sure that the soldering station temperature is adjustable.
- 2) Enter the correct password, or the initial password "000000".

There are three temperature channels in total. Long press "1", "2" and "3" keys on the main unit to quickly select the corresponding storage temperature of CH1, CH2 and CH3 respectively. The current temperature value can be changed through +/- key,

but the storage temperature of the three temperature channels will not be changed.

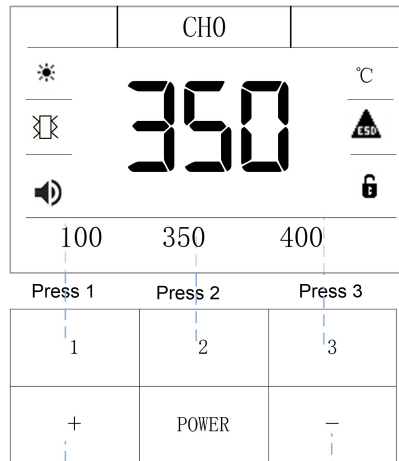

Press + button once to increase 1°C. press and hold it to continuously increase. Press - button once to decrease 1°C. press and hold it to continuously decrease.

10. Menu Settings

Enter the menu setting interface.

Press and hold "2" and "3" keys at the same time to enter the menu setting interface.

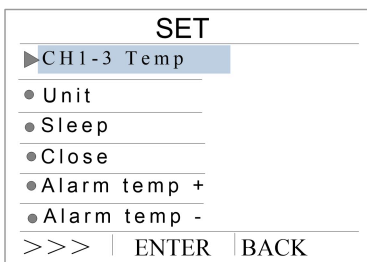

10. 1. Temperature Parameter Settings

- 1) Press "2" key to enter the "temperature modification interface
- 2) Press "+" or "-" key to change the value and Press "2" key to confirm.
- 3) Press "+" key to move down to modify temperature II / temperature III. The setting method is the same as above.
- 4) Press "2" to save and "3" to return to the main interface.

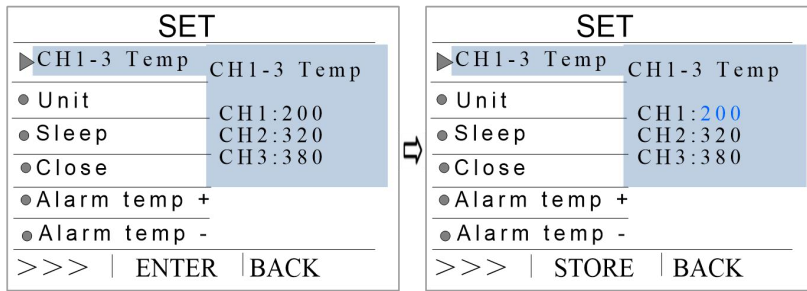

10. 2. Temperature Unit Settings

- 1) Press "1" or "+" or "-" key to select the temperature unit setting.
- 2) Press "2" key to enter the Celsius or Fahrenheit unit selection interface, and press "1" key to select the required unit.
- 3) Press "2" to save and "3" key to return to the main interface.

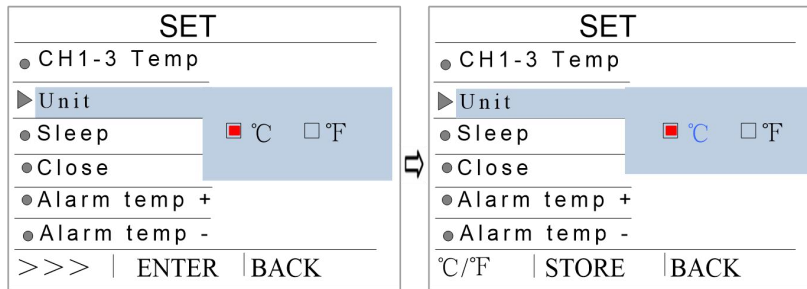

10. 3. Sleep Time Settings

- 1) Press "1" or "+" or "-" key to select "Sleep Time".
- 2) Press "2" key to enter the sleep time setting interface, and then press "1" key to select ON or OFF. OFF means to close the sleep setting function, and ON means to turn on the sleep setting function. Press "+" or "-" key to modify the sleep time. The setting range of sleep time is 5S ~ 99mins.
- 3) After setting the sleep time, press "2" key to save, and press "3" key to return to the main interface.

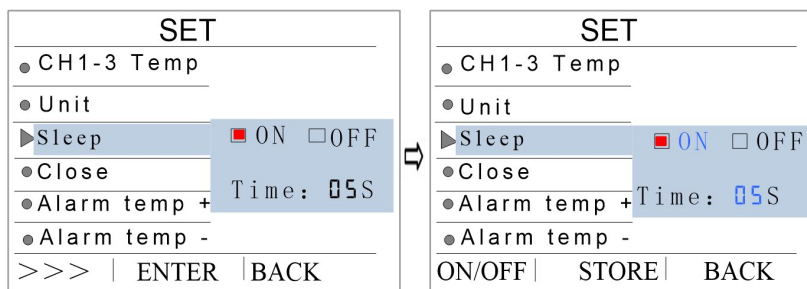

10. 4. Close Time Settings

- 1) Press "1" or "+" or "-" key to select "Close Time".
- 2) Press "2" key to enter the close time setting interface.
- 3) Press "1" key to select ON or OFF and press "+" or "-" key to modify the value. The setting range of close time is 1-240mins.
- 4) After setting the close time, press "2" key to save, and press "3" key to return to the main interface.

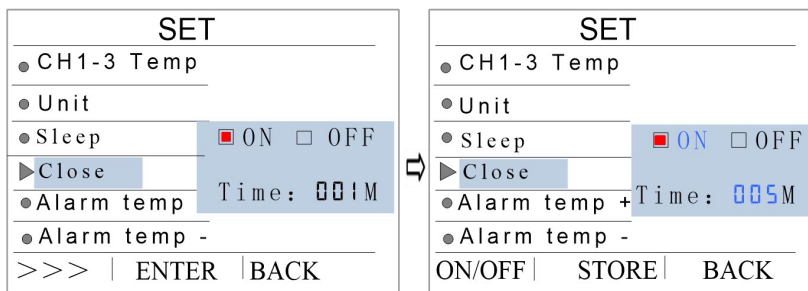

10. 5. Alarm Temperature Settings

- 1) Press "1" or "+" or "-" key to select "Alarm Temp+" or "Alarm Temp-".
- 2) Press "2" key to enter the alarm temperature setting interface.
- 3) Press "1" key to select ON or OFF. Off means to turn off the temperature alarm function, and ON means to turn on the temperature alarm function. Press "+" or "-" key to modify the alarm temperature range, and the range is 2 ~ 99 °C.
- 4) Press "2" key to confirm and "3" key to return to the main interface.

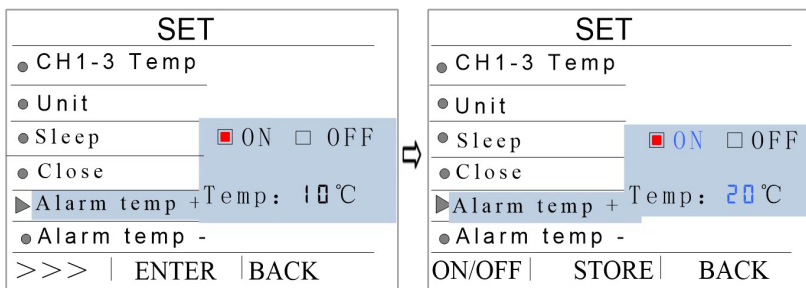

10. 6. Password Settings

- 1) Press "1" or "+" or "-" key to select "Password".
- 2) Press "2" key to enter password setting interface.
- 3) Press "2" key to enter the password input interface, and input the old password (original password 000000). Then press "2" key to enter the new password input interface. Press "+" or "-" key to select the value (0 ~ 9), and press 1 to change the digit.
- 4) Press 2 key to confirm and 3 key to return to the main interface.

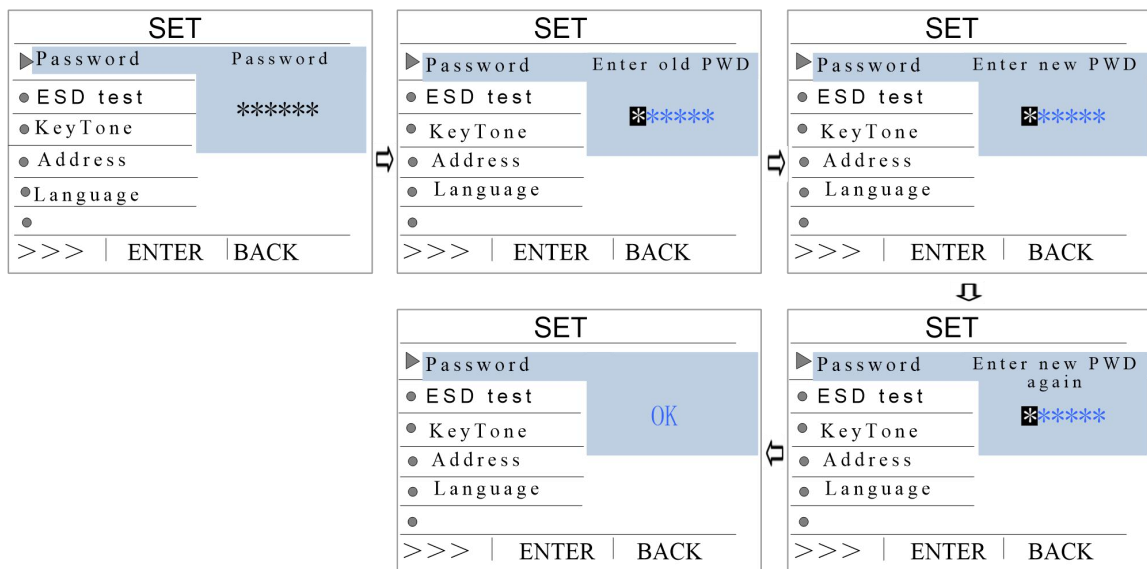

Note: After changing the password, to enter the menu setting interface, please enter the correct new password.

10. 7. ESD Function Settings

- 1) Press "1" or "+" or "-" key to select "ESD".
- 2) Press "2" key to enter the ESD setting interface. Press "1" key to select ON to turn on the "ESD Test" or OFF to turn off the "ESD Test" function.
- 3) Press "2" key to confirm and "3" key to return to the main interface.

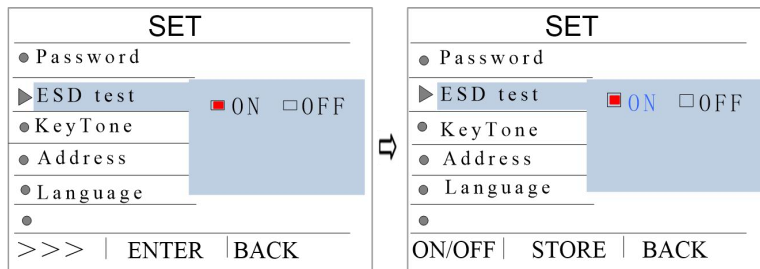

10. 8. Key Tone Settings

- 1) Press "1" or "+" or "-" key to select "Key Tone".
- 2) Press "2" key to enter the key tone setting interface. Press "1" key to select ON or OFF to switch the sound function.
- 3) Press "2" key to confirm and "3" key to return to the main interface.

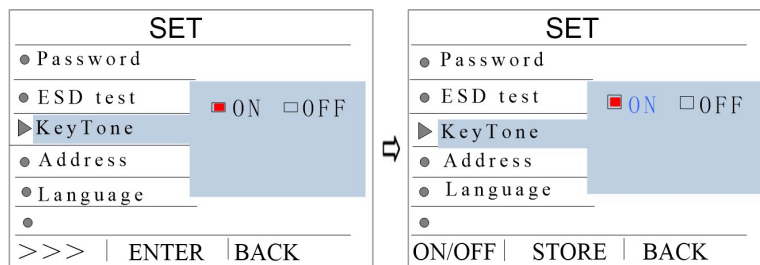

10. 9. Address Settings

- 1) Press "1" or "+" or "-" key to select "Address".
- 2) Press "2" key to set the address, and press "+" or "-" key to enter the address password. The address setting range is 01-99.
- 3) Press "2" key to confirm and "3" key to return to the main interface.

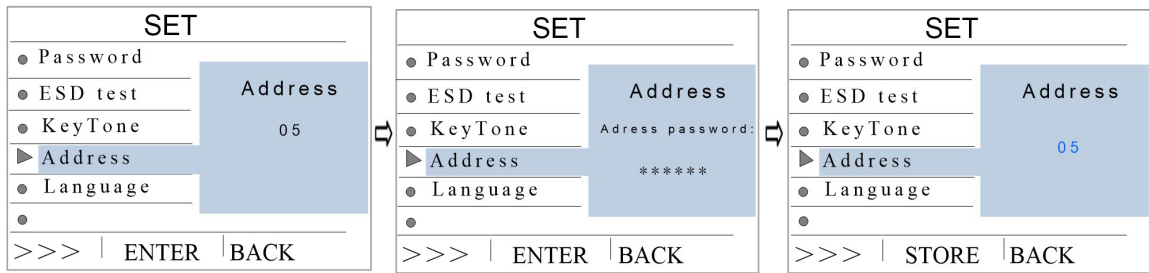

10. 10. Language Settings

- 1) Press "1" or "+" or "-" key to select "Language".
- 2) Press "2" key to enter the language setting interface.
- 3) Press "1" key to switch between Chinese Simplified, Chinese Traditional and English.
- 4) Press "2" key to confirm and "3" key to return to the main interface.

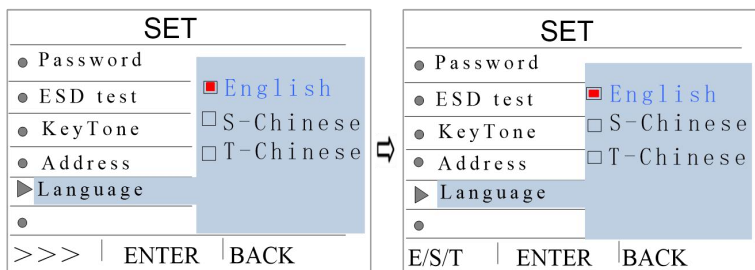

11. Temperature Calibration

Whenever the tip is replaced, the temperature of the tip shall be recalibrated.

Calibrate with tip thermometer

- 1) Set a certain temperature value of the soldering station.
- 2) When the temperature is stable, measure the temperature of the tip with thermometer and record the reading value.
- 3) Long press "1" and "3" keys at the same time, then the soldering station will enter the temperature calibration state, and the temperature value displayed on the screen will flash. Press "+" or "-" key to change the value and adjust the value to the actual temperature of the soldering station measured in step 2. Press 2 key (STORE) to

confirm, then "Successfully" will be displayed and return to the main interface automatically.

It is recommended to use 191 / 192 thermometer to measure the temperature of tips.

If the password is locked, the temperature will not be calibrated. The correct password must be entered before operation.



12. Maintenance of Tips

- 1) When the new tip is used for the first time, add tin to protect it when the temperature is 250 ~ 280 °C.
- 2) Select the appropriate tip size according to the size of soldering joints.
- 3) In order to prevent the oxidation of tips, a layer of soldering tin should be plated before placing it into the holder.
- 4) In order to avoid rapid cooling of tips, the cleaning sponge should not be wet with too much water. But using cleaning sponge that is not wet will damage the tips and lead to failure of tinning the tips.
- 5) When the tip is oxidized due to improper use, do not clean the surface coating by grinding but use metal filament or resurrection ointment to clean it at 250 ~ 280 °C.
- 6) When soldering, do not apply gravity to tips and avoid adding tin to the same place to operate.
- 7) Try to solder at low temperature, and the temperature is usually controlled at 320 ~ 380°C. If it is necessary to solder at high temperature, please analyze the adaptability of soldering station and tips before soldering.

13. Selection of Tips

- 1) It is very important to correctly select the size and shape of tips. A suitable tip can improve the efficiency and increase the durability.
- 2) The size of tips is directly related to the heat capacity. For continuous soldering, the larger the tip, the less the temperature drop. In addition, because the heat capacity of the large tips is higher and relatively low temperature can be used during soldering, the tips are not easy to oxidize and the service life is relatively prolonged.
- 3) Generally speaking, the selection of tip size is based on the standard that it does not affect adjacent components. Selecting the geometric dimension that can fully contact with the soldering joint can improve the soldering efficiency.

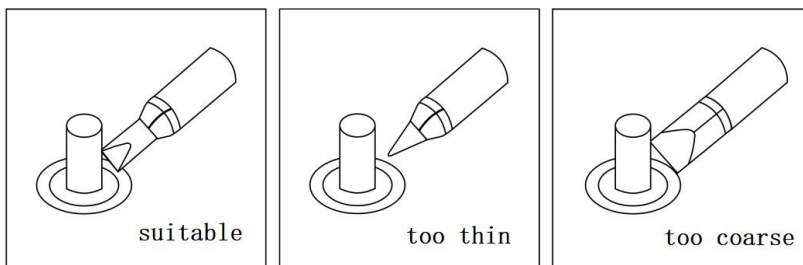

14. Troubleshooting

| NO. | Error display | Error description |
|-----|-----------------------|--|
| 1 | Sensor broken | Replace the sensor |
| 2 | Soldering pencil type | Replace the matching soldering pencil |
| 3 | No soldering pencil | 1. Insert the soldering pencil 2. Check that the soldering pencil is fully inserted |
| 4 | Heater open circuit | Replace the heater |
| 5 | Heater short circuit | Replace the heater |

15. List of Tips

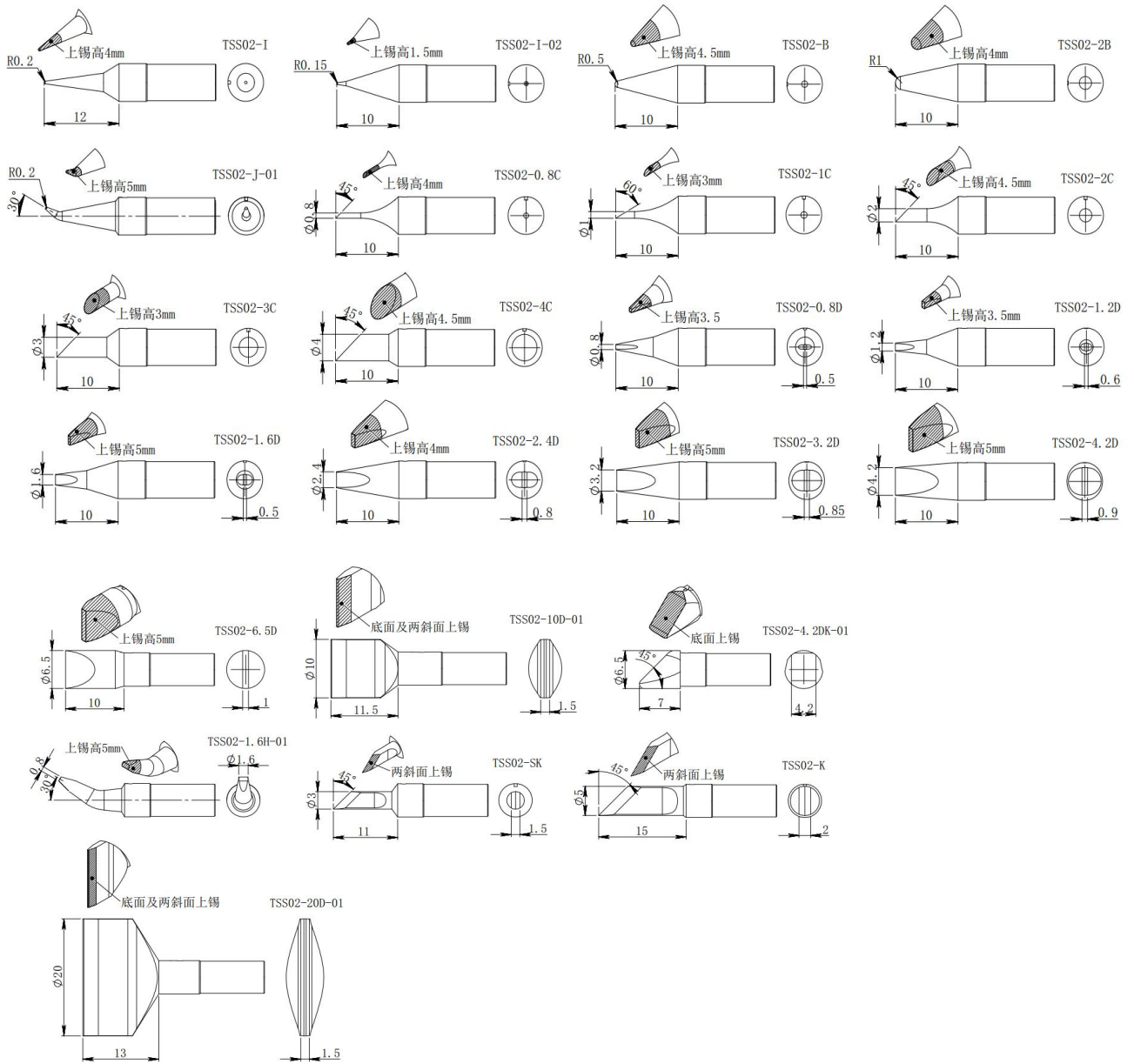

Warranty Card

- The warranty period of this product is calculated from the date of purchase. During the warranty period, if the product breaks down during normal use, show the original warranty card and enjoy free service in the authorized repair company (or our company). Please keep the purchase certificate and this warranty card and show it before maintenance.
- During the warranty period, the following repairs need to be paid:
 - a.Unable to offer valid warranty card or certificate;
 - b.The purchase date, sales company and other items are not completely filled in or the warranty card is altered;
 - c.Damage caused by failure to follow the use methods and precautions in the manual;
 - d.Damage caused by disassembly, repair and modification of products without authorization of the manufacturer;
 - e.Replacement of vulnerable and consumable parts.
- All items of the warranty card shall be completely filled in by the agent or user to obtain a 12-month warranty period.
- Please keep this warranty card properly. It will not be re-offered after.

QUICK INTELLIGENT EQUIPMENT CO., LTD.

ADD: NO.11, FengXiang Road, Wujin
High-Tech Industrial Development Zone,
Jiangsu, China

TEL: 86-519-86225678

FAX: 86-519-86558599

POSTCODE: 213167

WEBSITE: www.quick-global.com

Warranty Card

Type: _____

Model No.: _____

Serial No.: _____

Delivery Date: _____

Warranty File Card

Type: _____

Model No.: _____

Serial No.: _____

Delivery Date: _____

Address : _____

Postcode: _____

Telephone: _____

Contact Person: _____

QUICK INTELLIGENT EQUIPMENT CO., LTD.

ADD: NO.11, FengXiang Road, Wujin High-Tech Industrial
Development Zone, Jiangsu, China

TEL: 86-519-86225678

FAX: 86-519-86558599

POSTCODE: 213167

WEBSITE: www.quick-global.com

