

Lead-free Solder Pot

Instruction Manual



Thank you for purchasing our products. Please keep the instruction manual properly for future reference.

Contents

1. Safety Instructions.....	1
2. Overview.....	1
3. Product Characteristics.....	2
4. Product Specifications.....	3
5. Functional Descriptions.....	4
5.1. Dimensions.....	4
5.2. Part Descriptions.....	5
5.3. Key Descriptions.....	6
6. Operation.....	7
7. Temperature Calibration.....	8
8. Troubleshooting.....	9
9. Maintenance.....	10
10. Replace the solder pot	11

1.Safety Instructions



CAUTION

- During the installation and use of this product, all electrical safety regulations of the country and regions must be strictly observed.
- The power supply must be disconnected when disassembling the product. Do not operate with power on.
- If the product does not work properly, please contact the supplier or our company, and do not disassemble or change the product in any way. We are not responsible for any problems caused by unauthorized maintenance or modification.



WARNING

- The product should be used away from places where there is magnetic interference.
- Don't install the product in a place where the surface is easy to shake or be impacted, as it may damage the product.
- Don't install the product in places where it may be exposed to rain or moisture.
- Don't use in flammable and explosive environments.
- In the process of working or when the solder pot is not fully cooled, do not touch the metal parts around the pot to avoid scalding.
- High temperature state (above 400 °C) is easy to oxidize the surface of the soldering layer, which is not conducive to soldering. At the same time, high temperature working state will also shorten the life of the solder pot, so it should work at a lower temperature as far as possible.
- When using a solder pot to melt the solder for the first time, please set a lower temperature (such as 300 °C) until the temperature is stable, and then set a higher temperature (such as 400 °C).
- When it is not in use, please turn off the power to prolong its life.
- Please unplug the power cord when the product is not used for a long time.

2.Overview

The control circuit of the solder pot adopts sensor closed-loop temperature control, which is accurate and stable. The solder pot is sprayed with corrosion-resistant and heat resistant nano-ceramics with a long service life and is suitable for lead-free operation. The solder pot heating element surrounds the pot, and is with high thermal efficiency, fast temperature rise and small temperature fluctuation. In the structural design, the factors such as heat conduction, heat insulation and heat preservation are fully considered to avoid the loss of heat and the influence of high temperature on the solder pot parts, circuit boards and components. Therefore, this solder pot is an electronic tool with reasonable structure, rigorous and excellent performance.

3.Product Characteristics

- Sensor closed-loop temperature control.
- Digital temperature display and calibration.
- Working time available to set.
- Long service life, suitable for lead-free operation.
- Quick temperature rise, with accurate and stable temperature.
- Reasonable and exquisite structure, simple and convenient to use.

4.Product Specifications

Model	
Power consumption	600W
Voltage	AC 110V/220V/230V/240V
Solder pot size	98*130*58(H)mm
Temperature range	100~450°C
Working time range	0~999hours
Temperature stability	±5°C
Dimensions(L*W*H)	334*200*114mm
Weight	About 4.2kg

5.Functional Descriptions

5. 1. Dimensions

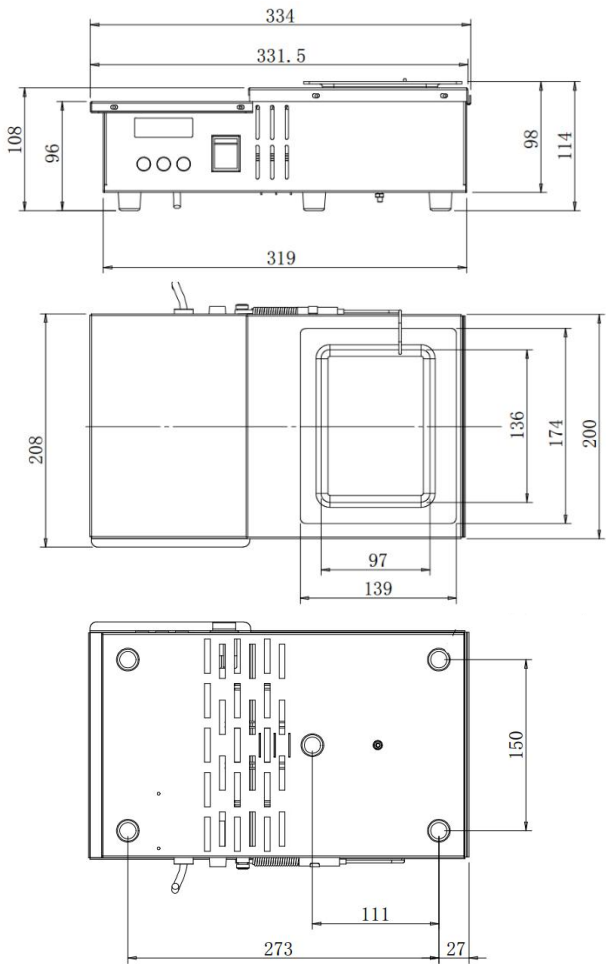

Unit: mm

5. 2. Part Descriptions

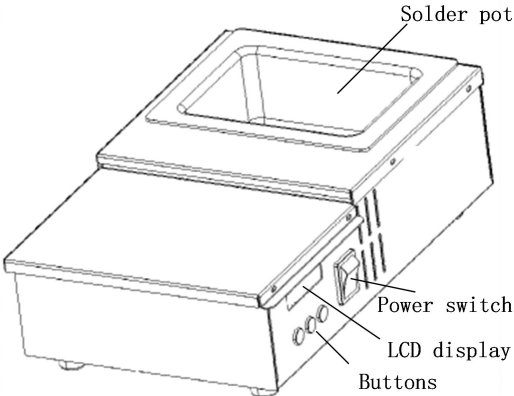

5. 3. Key Descriptions

Symbols	Function Descriptions
▲ and ▼	Adjust the set temperature.
/▲ and ▼	<p>Turn off the power switch, long press the "▲" and "▼" keys at the same time, then turn on the power switch to connect the power supply, and then enter the working time setting. Press the "▲" or "▼" key to adjust the working time; press the "" key to exit the working time and display the accumulated working time; press the "*" key again to return to the working state.</p> <p>Press and hold the "*", "▲" and "▼" keys at the same time to enter the temperature calibration.</p>

6.Operation

Note:

Before use please confirm whether the power supply voltage is consistent with the rated voltage value on the product label.

- 1) Place the solder pot on the flat workbench that is resistant to high temperatures and is flame retardant, or place a metal backing plate at the bottom of the solder pot.
- 2) Place a suitable amount of solder in the solder pot to immerse the bottom of the sensor, but at least about 10mm below the highest point of the pot.
- 3) Insert the power plug into the socket.
- 4) Turn on the power switch "POWER" on the panel, and the solder pot begins to heat. The screen displays the set temperature "set temp" and the actual temperature "real temp".
- 5) Press the "▲" or "▼" key to adjust the set temperature.
- 6) It will take a period of time to melt the solder. When the solder is completely melted and the temperature is constant, the heating indicator does not flash, and then the work can be carried out. If there is oxide floating on the solder surface, remove the oxide before use.
- 7) Please turn off the power switch of the pot after using.
- 8) If you need to set the working time of the solder pot to make the pot work to the set time and then stop heating: turn off the power switch, and then press and hold the "▲" and "▼" keys at the same time, turn on the power switch, and connect the power. At this time, the LED displays "off time" and the set working time. Press the "▲" or "▼" key to adjust the working time; press the "*" key to exit the working time and display the accumulated working time; press the "*" key again to return to the working state.

7. Temperature Calibration

The temperature should be calibrated after the heater or solder pot is replaced.

- 1) Set the solder pot temperature to 300°C.
- 2) After the temperature is stable, immerse the external sensor temperature measuring head of temperature tester into the solder pot, and observe the reading value after the displayed temperature is stable.
- 3) If the displayed temperature tester is not 300°C, please calibrate the temperature. Press "▲", "▼" and "*" at same time to enter the temperature calibration mode. The screen displays "cal temp" and "set temp".
- 4) Press "▲" or "▼" key, input the calibrate temperature "cal temp". Then press "*" key to confirm and enter the working mode
- 5) If there is still an error in temperature, please repeat the calibration.

Note: It is recommended to use QUICK 191/192 to measure the temperature.

8.Troubleshooting

No.	Error display	Error description
1	S-E	When the sensor or any part of the sensor circuit fails, the current to the solder pot is cut off and the buzzer gives an alarm sound.
2	If the setting temperature of the solder pot is high, after heating for a period of time, the solder temperature is still room temperature.	The heater may be damaged.

9.Maintenance

Frequency	Description
Every day	Clean the tin slag on the surface of the solder pot.
Every week	<ol style="list-style-type: none"><li data-bbox="404 495 997 561">1. Clean the residual soldering flux on the surface of the solder pot with alcohol.<li data-bbox="404 584 997 650">2. Use external sensors to measure the temperature of the solder pot.
Every six months or one year	Empty the solder pot and thoroughly clean the interior of the solder pot. Check for any signs of corrosion to determine if replacement is necessary.

10. Replace the solder pot

- 1) Turn off the power switch and remove the sensor placed in the solder while the solder is not cooled and not yet solidified. Once the solder has cooled down, remove the solder pot.
- 2) Loosen the nut that secures the solder pot at the bottom of the unit and remove it.
- 3) Unscrew the cover plate and solder pot assembly, and remove the cover plate.
- 4) Pick up the solder pot from the front, then replace it with a new one in the opposite direction and screw down.



Note: In case the heater or sensor is damaged, find a specialist or contact distributor or manufacturer for maintenance.

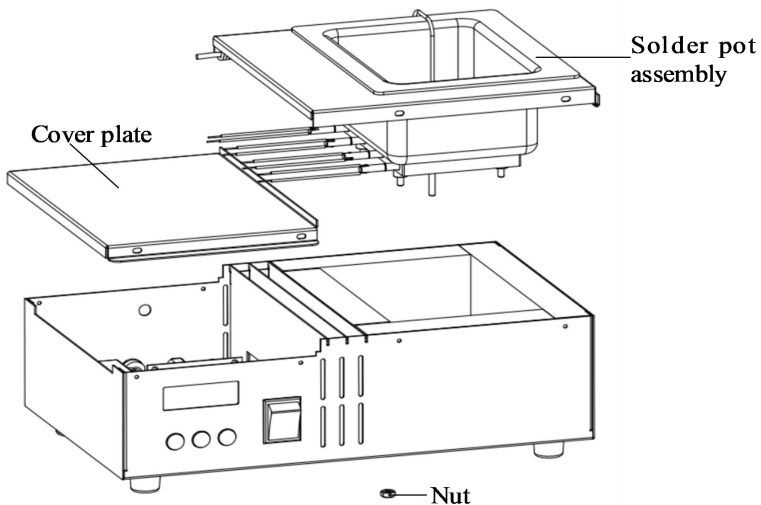

401H000440