

修订	标记	修改摘要	签名	日期
REV	MARK	REVISION DESCRIPTION	SIGNATURE	DATE
AO		NEW DWG		2016-03-12

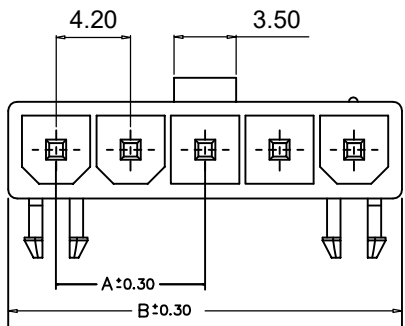

- Specifications :**
- Voltage rating: 600V AC / DC
  - Current rating: 9A AC / DC
  - Withstanding voltage: 1500V AC/minute
  - Temperature range: -25°C~+85°C
  - Insulation resistance: ≥100MΩ
  - Contact resistance: ≤10mΩ
  - After environmental testing: ≤20mΩ

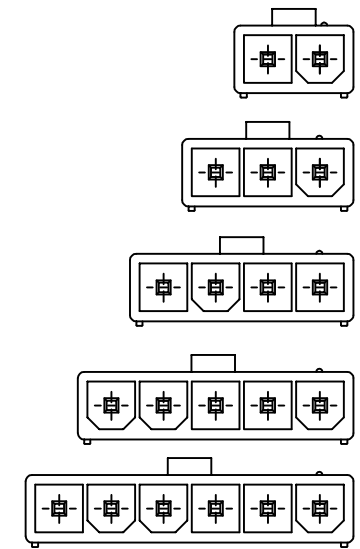
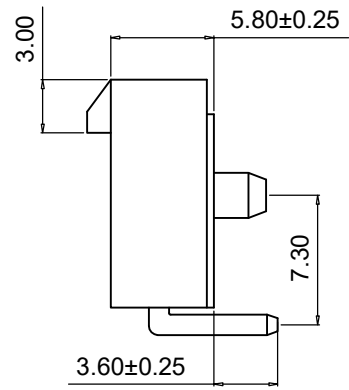
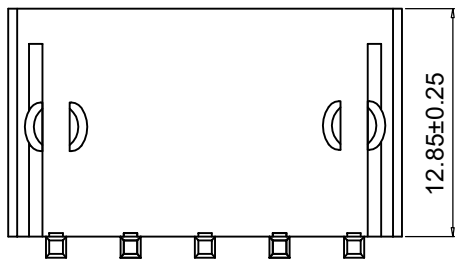

Contact	Dimensions	
	A	B
01	---	5.40
02	4.20	9.60
03	8.40	13.80
04	12.60	18.00
05	16.80	22.20
06	21.00	26.40

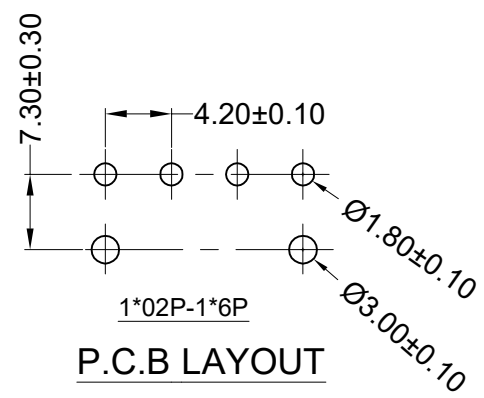

HDGC4201WR-F-1xXP	Nylon 66 UL 94V-2	Brass	Tin-Plated	4201H
PART NO	Material	Material(Pin)	Finish(Pin)	Mates With ZLT Housing

		<b>深圳市华德共创科技有限公司</b> Shenzhen Huade co-create Technology Co.,LTD 电话: 0755-27111216 传真: 0755-29940187						
-TOLERANCES- UNLESS OTHERWISE SPECIFIED 公差参数表				TITLE: 产品名称: MX4.2带柱弯针				
X.X	±0.30	X.X*	±3°	APPD: 核准:	PART NO: 产品编号: 5557WRF-1xXP (HDGC4201WR-F-1xXP)			
X.XX	±0.20	X.XX*	±2°	CHECK: 校对: 王建业	DATE	SCALE	UNIT	CODE NUMBER
X.XXX	±0.10	X.XXX*	±1°	DRAW: 绘图: 黄艳兰	2016-03-12	1:1	mm	A001

由 Autodesk 教育版产品制作

由 Autodesk 教育版产品制作