

3	焊片 Fitting Nail	黄铜	2	电镀(锡):整个表面镀底镍 30u"MIN,再镀锡80u"MIN
2	端子 Contact	黄铜	N*1	电镀(锡):整个表面镀底镍 30u"MIN,再镀锡80u"MIN
1	基座 Wafer	LCP (UL94V-0)	1	米色
序号	名称	材料	数量	备注

SUGGESTED PCB LAYOUT
(COMPONENT SIDE)

Part No	Pin	A	B	C
ZX-VH3.96-2PLT	2	3.96	11.88	8.60
ZX-VH3.96-3PLT	3	7.92	15.84	12.56
ZX-VH3.96-4PLT	4	11.88	19.80	16.52
ZX-VH3.96-5PLT	5	15.84	23.76	20.48
ZX-VH3.96-6PLT	6	19.80	27.72	24.44
ZX-VH3.96-7PLT	7	23.76	31.68	28.40
ZX-VH3.96-8PLT	8	27.72	35.64	32.36
ZX-VH3.96-9PLT	9	31.68	39.60	36.32
ZX-VH3.96-10PLT	10	35.64	43.56	40.28

- 技术要求:
1. 塑件材料:LCP(UL-94V-0)
 2. 接触件:黄铜镀锡
 3. 接触电阻: $\leq 30m\Omega$
 4. 绝缘电阻: $\geq 1000M\Omega$
 5. 额定电压:250V AC DC
 6. 额定电流:7.0A AC DC
 7. 耐压:能承受1000V AC/Minute
 8. 工作温度: $-25^{\circ}\sim +85^{\circ}$
 9. 可焊性试验:浸锡面积 $\geq 95\%$ 温度260, 时间 2.5 ± 0.5 秒
 10. 铅和镉等六大有害物质含量要符合环保要求.

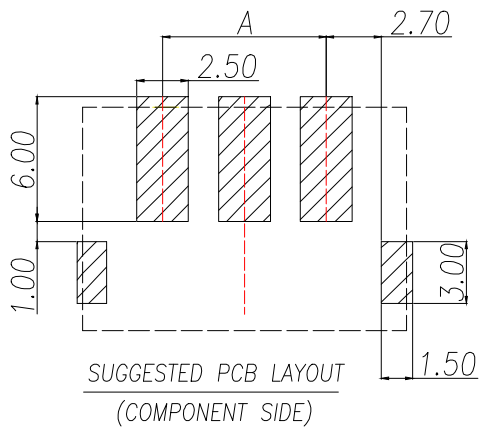

制图 DRAWN	变更内容 DESCRIPTION	日期 DATE	GENERAL TOLERANCE		制图 DRAWING	ROSE LEO JOHN	料号 PART NO.	ZX-VH3.96-NPLT	版本 REV.	A
			.X±0.25	X'::±3'	审核 CHECK		品名 TITLE	压接式(条形)连接器	页次 SHEET	1/1
			.XX±0.12		核准 APPROVAL		客户料号 CUTM.NO.			
			.XXX±0.05		单位 UNITS		MM	比例 SCALE	1:1	