

SURFACE MOUNT SCHOTTKY BARRIER RECTIFIER

Features

- ◆ The plastic package carries Underwriters Laboratory Flammability Classification 94V-0
- ◆ For surface mounted applications
- ◆ Metal silicon junction, majority carrier conduction
- ◆ Low power loss, high efficiency
- ◆ Built-in strain relief, ideal for automated placement
- ◆ High forward surge current capability
- ◆ High temperature soldering guaranteed:
250 °C/10 seconds at terminals

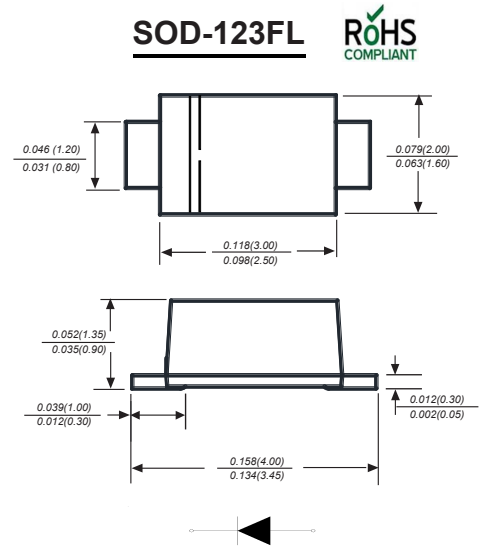

Mechanical Data

Case : JEDEC SOD-123FL molded plastic body
 Terminals : Solderable per MIL-STD-750, Method 2026
 Polarity : Color band denotes cathode end
 Mounting Position : Any
 Weight : 0.0007 ounce, 0.02 grams

Maximum Ratings And Electrical Characteristics

Ratings at 25°C ambient temperature unless otherwise specified.

Single phase half-wave 60Hz, resistive or inductive load, for capacitive load current derate by 20%.

| Parameter | SYMBOLS | DSK32 | DSK34 | DSK35 | DSK36 | DSK38 | DSK310 | DSK315 | DSK320 | UNITS |
|--|-----------------|-------------|-------|-------|-------|-------|--------|--------|--------|-------|
| Marking Code | | K32 | K34 | K35 | K36 | K38 | K310 | K315 | K320 | |
| Maximum repetitive peak reverse voltage | V_{RRM} | 20 | 40 | 50 | 60 | 80 | 100 | 150 | 200 | V |
| Maximum RMS voltage | V_{RMS} | 14 | 28 | 35 | 42 | 56 | 70 | 105 | 140 | V |
| Maximum DC blocking voltage | V_{DC} | 20 | 40 | 50 | 60 | 80 | 100 | 150 | 200 | V |
| Maximum average forward rectified current at TL (see fig. 1) | $I_{(AV)}$ | 3.0 | | | | | | | | A |
| Peak forward surge current 8.3ms single half sine-wave superimposed on rated load (JEDEC Method) | I_{FSM} | 80 | | | | | | | | A |
| Maximum instantaneous forward voltage at 3.0A | V_F | 0.55 | | 0.70 | | 0.85 | | 0.95 | | V |
| Maximum DC reverse current $T_A=25^\circ C$ at rated DC blocking voltage $T_A=100^\circ C$ | I_R | 0.5 | | | | 0.3 | | | | mA |
| | | 10.0 | | | | 5.0 | | | | |
| Typical junction capacitance (NOTE 1) | C_J | 250 | | | | 160 | | | | pF |
| Typical thermal resistance (NOTE 2) | $R_{\theta JA}$ | 80.0 | | | | | | | | °C/W |
| Operating junction temperature range | T_J | -55 to +150 | | | | | | | | °C |
| Storage temperature range | T_{STG} | -55 to +150 | | | | | | | | °C |

Note: 1. Measured at 1MHz and applied reverse voltage of 4.0V D.C.

Typical Characteristics

Fig.1 Forward Current Derating Curve

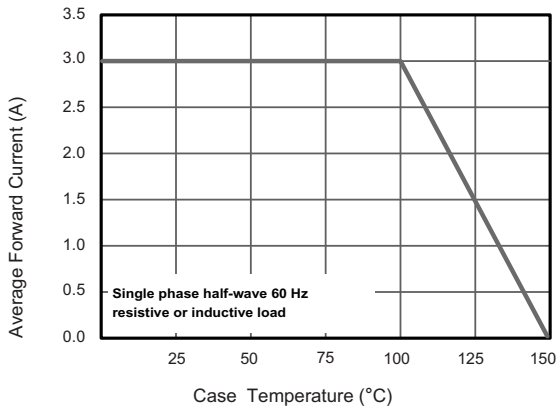

Fig.2 Typical Reverse Characteristics

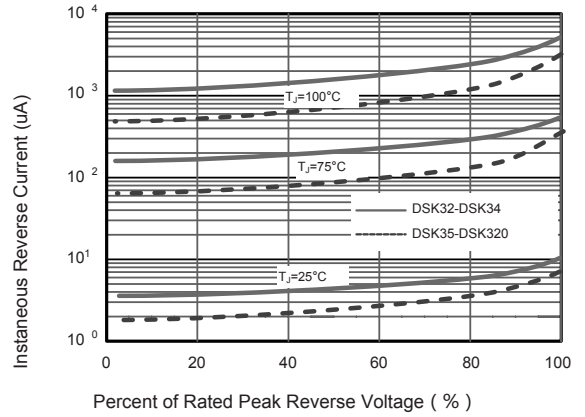

Fig.3 Typical Forward Characteristic

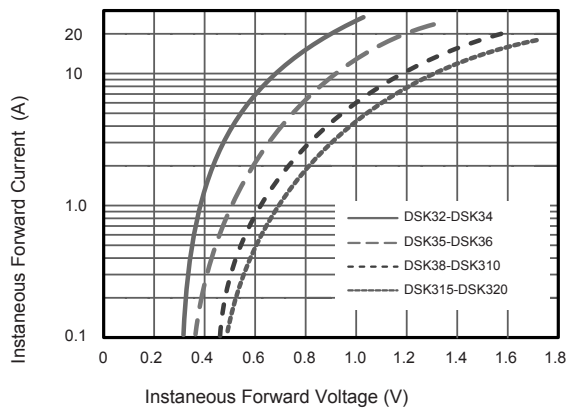

Fig.4 Typical Junction Capacitance

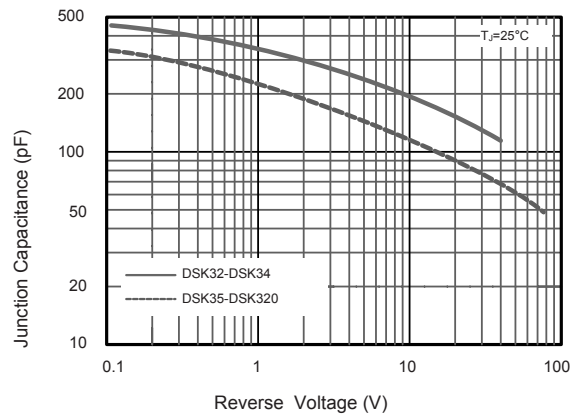

Fig.5 Maximum Non-Repetitive Peak Forward Surge Current

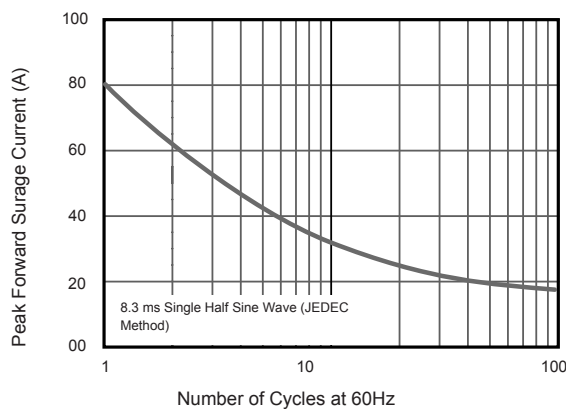
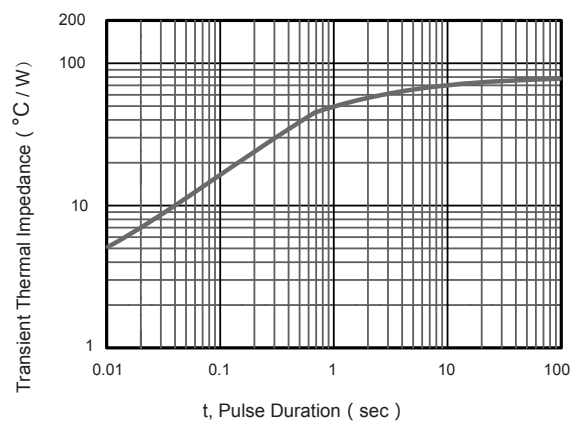
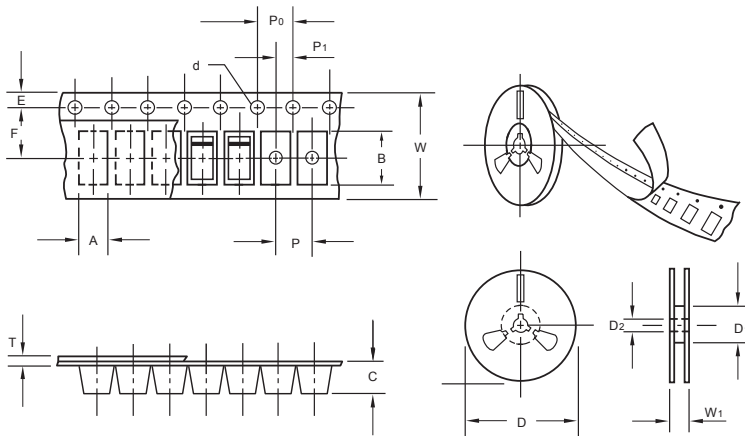

Fig.6 Typical Transient Thermal Impedance



The curve above is for reference only.

Packing information



unit:mm

| Item | Symbol | Tolerance | SOD-123FL |
|--------------------------|--------|-----------|-----------|
| Carrier width | A | 0.1 | 2.1 |
| Carrier length | B | 0.1 | 4.0 |
| Carrier depth | C | 0.1 | 1.60 |
| Sprocket hole | d | 0.05 | 1.55 |
| 7" Reel outside diameter | D | 2.0 | 178.00 |
| 7" Reel inner diameter | D1 | min | 50.0 |
| Feed hole diameter | D2 | 0.5 | 13.00 |
| Sprocket hole position | E | 0.1 | 1.75 |
| Punch hole position | F | 0.1 | 3.50 |
| Punch hole pitch | P | 0.1 | 4.00 |
| Sprocket hole pitch | P0 | 0.1 | 4.00 |
| Embossment center | P1 | 0.1 | 2.00 |
| Overall tape thickness | T | 0.1 | 0.25 |
| Tape width | W | 0.3 | 8.15 |
| Reel width | W1 | 1.0 | 10.5 |

Note: Devices are packed in accordance with EIA standard RS-481-A and specifications listed above.

Reel packing

| PACKAGE | REEL SIZE | REEL (pcs) | COMPONENT SPACING (m/m) | BOX (pcs) | INNER BOX (m/m) | REEL DIA, (m/m) | CARTON SIZE (m/m) | CARTON (pcs) | APPROX. GROSS WEIGHT (kg) |
|-----------|-----------|------------|-------------------------|-----------|-----------------|-----------------|-------------------|--------------|---------------------------|
| SOD-123FL | 7" | 3,000 | 4.0 | 45,000 | 190*190*190 | 178 | 400*400*220 | 180,000 | 9.0 |

Suggested Pad Layout

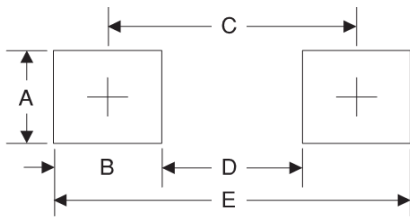

| Symbol | Unit (mm) | Unit (inch) |
|--------|-----------|-------------|
| A | 1.2 | 0.047 |
| B | 1.2 | 0.047 |
| C | 3.2 | 0.126 |
| D | 2 | 0.079 |
| E | 4.4 | 0.173 |

Important Notice and Disclaimer

Microdiode Semiconductor(Shenzhen) reserves the right to make changes to this document and its products and specifications at any time without notice. Customers should obtain and confirm the latest product information and specifications before final design, purchase or use.

Microdiode Semiconductor(Shenzhen) makes no warranty, representation or guarantee regarding the suitability of its products for any particular purpose, nor does Microdiode Semiconductor(Shenzhen) assume any liability for application assistance or customer product design. Microdiode Semiconductor(Shenzhen) does not warrant or accept any liability with products which are purchased or used for any unintended or unauthorized application.

No license is granted by implication or otherwise under any intellectual property rights of Microdiode Semiconductor(Shenzhen).

Microdiode Semiconductor(Shenzhen) products are not authorized for use as critical components in life support devices or systems without express written approval of Microdiode Semiconductor(Shenzhen).

