

SUGGESTED PCB LAYOUT
(COMPONENT SIDE)

技术要求:

1. 塑件材料: PA66 (UL-94V-0)
2. 接触件: 黄铜镀锡
3. 接触电阻: $\leq 20m\Omega$
4. 绝缘电阻: $\geq 1000M\Omega$
5. 额定电压: 250V AC DC
6. 额定电流: 3.0A AC DC
7. 耐压: 能承受 1000V AC/Minute
8. 工作温度: $-25^{\circ} \sim +85^{\circ}$
9. 可焊性试验: 浸锡面积 $\geq 95\%$ 温度 $235^{\circ} \pm 5$, 时间 2.5 ± 0.5 秒
10. 铅和镉等六大有害物质含量要符合环保要求.

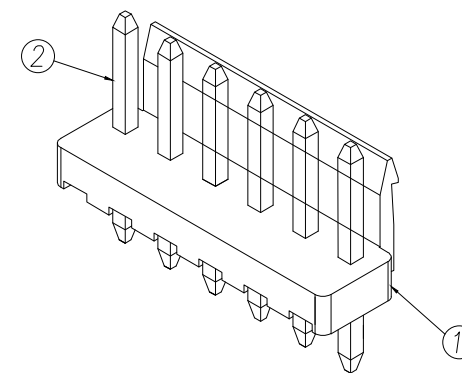

Part No	Pin	A	B
BX-VH3.96-2PZZ	2	3.96	7.92
BX-VH3.96-3PZZ	3	7.92	11.88
BX-VH3.96-4PZZ	4	11.88	15.84
BX-VH3.96-5PZZ	5	15.84	19.80
BX-VH3.96-6PZZ	6	19.80	23.76
BX-VH3.96-7PZZ	7	23.76	27.72
BX-VH3.96-8PZZ	8	27.72	31.68
BX-VH3.96-9PZZ	9	31.68	35.64
BX-VH3.96-10PZZ	10	35.64	39.60
...
BX-VH3.96-20PZZ	20	75.24	79.20

制图 DRAWN	变更内容 DESCRIPTION	日期 DATE	GENERAL TOLERANCE	
			.X±0.25	X'..±3'
			.XX±0.12	
			.XXX±0.05	

制图 DRAWING	ROSE
审核 CHECK	LEO
核准 APPROVAL	JOHN
单位 UNITS	MM
比例 SCALE	1:1

料号 PART NO.	ZX-VH3.96-NPZZ	版本 REV.	A
品名 TITLE	压接式连接器	页次 SHEET	1/1
客户料号 CUTM.NO.			
兆星精密电子(深圳)有限公司 ShenZhen ZhaoXing Precision electronics Co., Ltd.			