

300mA CMOS Voltage Regulators

Features

- Quiescent Current: 1.5 μ A
- Input Voltage Range: 24V
- Output Current: 300mA
- Low Dropout Voltage: 300mV(Max.)@100mA($V_{OUT}=3.3V$)
- Output Voltage: 3.0V,3.3V,3.6V,4.0V,4.4V,5.0V
- Output Voltage Accuracy: $\pm 2\%$ (Typ.)
- Low Power Consumption

Applications

- Battery Power Supply Equipment
- Communication Equipment
- Audio/Video Equipment
- Monitor Equipment

General Description

The HR73 Series consists of a current limiter circuit, a driver transistor, a precision reference voltage and an error correction circuit. The series is compatible with low ESR ceramic capacitors. The current limiter's foldback circuit operates as a short circuit protection as well as the output current limiter for the output pin.

Reference News

SOT-23-3L Marking:	SOT-89 Marking:
HR73L30T4: 7330	HR73L30V: 7330
HR73L33T4: 7333	HR73L33V: 7333
HR73L36T4: 7336	HR73L36V: 7336
HR73L40T4: 7340	HR73L40V: 7340
HR73L44T4: 7344	HR73L44V: 7344
HR73L50T4: 7350	HR73L50V: 7350

Part Numbering

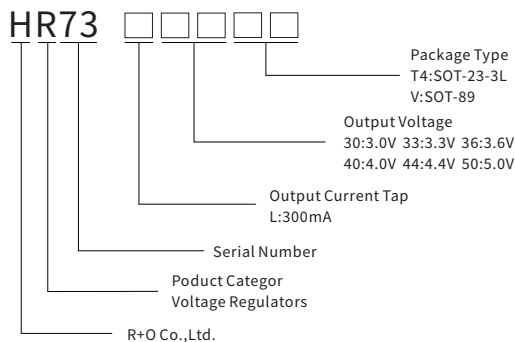

Block Diagram

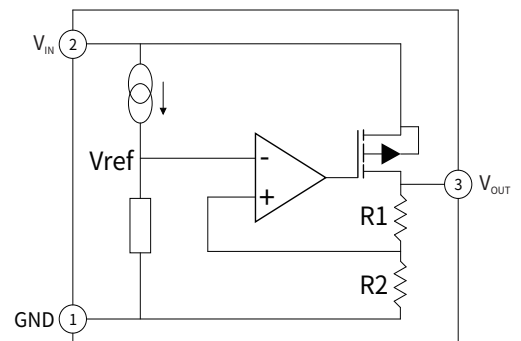

Ordering Information

Package	Package Code	Unit Weight(g)	Reel(pcs)	Box(pcs)	Carton(pcs)	Delivery Mode	MSL
SOT-23-3L	R1	0.0132	3000	30000	180000	7"	3
SOT-89	R1	0.045	1000	8000	48000	7"	3

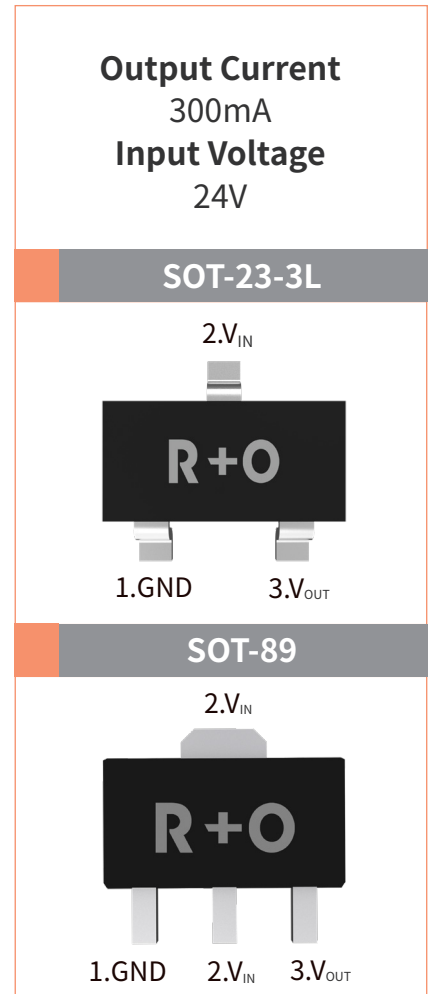

● Typical Application Circuit

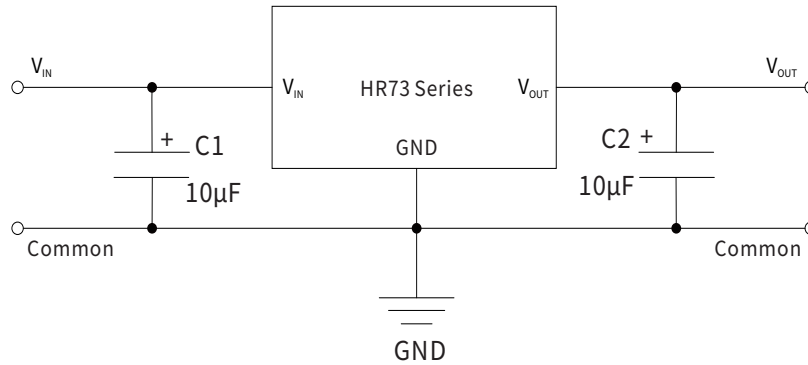

● Absolute Maximum Ratings (Ta=25°C Unless otherwise specified)

Parameter	Symbol	Value	Unit
Input Voltage Limit	V_{IN}	24	V
Operating Current	I_o	300	mA
Power Dissipation	P_D (SOT-23-3L)	200	mW
	P_D (SOT-89)	500	
Thermal Resistance Junction-Ambient	$R_{\theta JA}$ (SOT-23-3L)	625	°C /W
	$R_{\theta JA}$ (SOT-89)	250	
Solder Temperature/Time	T_d	260/10	°C /S
Operating Ambient Temperature	T_A	-40~+85	°C
Junction and Storage Temperature	T_J, T_{stg}	-50~+125	°C

Note: Exceed these limits to damage to the device, exposure to absolute maximum rating conditions may affect the reliability of the chip.

● Electrical Characteristics(HR73L30T4/V) (Ta=25°C Unless otherwise specified)

Parameter	Symbol	Conditions	Min.	Typ.	Max.	Unit
Output Voltage	V_{OUT}	$I_{OUT}=10mA, V_{IN}=5V$	2.94	3	3.06	V
Output Current	I_o	$V_{IN}=5V$	300	—	—	mA
Dropout Voltage	V_D	$I_{OUT}=100mA, \Delta V_{OUT}=2\%$	—	210	300	mV
Quiescent Current	I_Q	$I_{OUT}=0mA$	—	1.5	3	µA
Line Regulation	$\Delta V_{OUT} / \Delta V_{IN} \cdot V_{OUT}$	$I_{OUT}=1mA$ $4V \leq V_{IN} \leq 20V$	—	—	0.2	%/V
Output Short Current	I_{lim}	$V_{OUT}=0V$	—	400	—	mA
Output Voltage Temperature Coefficient	$\Delta V_{OUT} / \Delta T_A \cdot V_{OUT}$	$I_{OUT}=10mA, V_{IN}=5V$ $T_A=-40\sim 85^\circ C$	—	±100	—	ppm/°C

Note: The dropout voltage is defined as $V_{IN} - V_{OUT}$, when V_{OUT} is 98% of the normal value of V_{OUT} .

● Electrical Characteristics(HR73L33T4/V) (Ta=25°C Unless otherwise specified)

Parameter	Symbol	Conditions	Min.	Typ.	Max.	Unit
Output Voltage	V_{OUT}	$I_{OUT}=10mA, V_{IN}=5.3V$	3.234	3.3	3.366	V
Output Current	I_O	$V_{IN}=5.3V$	300	—	—	mA
Dropout Voltage	V_D	$I_{OUT}=100mA, \Delta V_{OUT}=2\%$	—	195	300	mV
Quiescent Current	I_Q	$I_{OUT}=0mA$	—	1.5	3	μA
Line Regulation	$\Delta V_{OUT} / \Delta V_{IN} \cdot V_{OUT}$	$I_{OUT}=1mA$ $4.3V \leq V_{IN} \leq 20V$	—	0.2	—	%/V
Load Regulation	ΔV_{OUT}	$1mA \leq I_{OUT} \leq 300mA$ $V_{IN}=5.5V$	—	37	100	mV
Output Short Current	I_{lim}	$V_{OUT}=0V$	—	400	—	mA
Output Voltage Temperature Coefficient	$\Delta V_{OUT} / \Delta T_A \cdot V_{OUT}$	$I_{OUT}=10mA, V_{IN}=5.3V$ $T_A=-40\sim 85^\circ C$	—	± 100	—	ppm/ $^\circ C$

Note: The dropout voltage is defined as $V_{IN} - V_{OUT}$, when V_{OUT} is 98% of the normal value of V_{OUT} .

● Electrical Characteristics(HR73L36T4/V) (Ta=25°C Unless otherwise specified)

Parameter	Symbol	Conditions	Min.	Typ.	Max.	Unit
Output Voltage	V_{OUT}	$I_{OUT}=10mA, V_{IN}=5.6V$	3.528	3.6	3.672	V
Output Current	I_O	$V_{IN}=5.6V$	300	—	—	mA
Dropout Voltage	V_D	$I_{OUT}=100mA, \Delta V_{OUT}=2\%$	—	180	300	mV
Quiescent Current	I_Q	$I_{OUT}=0mA$	—	1.5	3	μA
Line Regulation	$\Delta V_{OUT} / \Delta V_{IN} \cdot V_{OUT}$	$I_{OUT}=1mA$ $4.6V \leq V_{IN} \leq 20V$	—	0.2	—	%/V
Load Regulation	ΔV_{OUT}	$1mA \leq I_{OUT} \leq 300mA$ $V_{IN}=5.6V$	—	37	100	mV
Output Short Current	I_{lim}	$V_{OUT}=0V$	—	400	—	mA
Output Voltage Temperature Coefficient	$\Delta V_{OUT} / \Delta T_A \cdot V_{OUT}$	$I_{OUT}=10mA, V_{IN}=5.6V$ $T_A=-40\sim 85^\circ C$	—	± 100	—	ppm/ $^\circ C$

Note: The dropout voltage is defined as $V_{IN} - V_{OUT}$, when V_{OUT} is 98% of the normal value of V_{OUT} .

● Electrical Characteristics(HR73L40T4/V) (Ta=25°C Unless otherwise specified)

Parameter	Symbol	Conditions	Min.	Typ.	Max.	Unit
Output Voltage	V_{OUT}	$I_{OUT}=10mA, V_{IN}=6V$	3.92	4	4.08	V
Output Current	I_O	$V_{IN}=6V$	300	—	—	mA
Dropout Voltage	V_D	$I_{OUT}=100mA, \Delta V_{OUT}=2\%$	—	170	300	mV
Quiescent Current	I_Q	$I_{OUT}=0mA$	—	1.5	3	μA
Line Regulation	$\Delta V_{OUT} / \Delta V_{IN} \cdot V_{OUT}$	$I_{OUT}=1mA$ $5V \leq V_{IN} \leq 20V$	—	0.2	—	%/V
Load Regulation	ΔV_{OUT}	$1mA \leq I_{OUT} \leq 300mA$ $V_{IN}=6V$	—	37	100	mV
Output Short Current	I_{lim}	$V_{OUT}=0V$	—	400	—	mA
Output Voltage Temperature Coefficient	$\Delta V_{OUT} / \Delta T_A \cdot V_{OUT}$	$I_{OUT}=10mA, V_{IN}=6V$ $T_A=-40\sim 85^\circ C$	—	± 100	—	ppm/ $^\circ C$

Note: The dropout voltage is defined as $V_{IN} - V_{OUT}$, when V_{OUT} is 98% of the normal value of V_{OUT} .

● Electrical Characteristics(HR73L44T4/V) (Ta=25°C Unless otherwise specified)

Parameter	Symbol	Conditions	Min.	Typ.	Max.	Unit
Output Voltage	V_{OUT}	$I_{OUT}=10mA, V_{IN}=6.4V$	4.312	4.4	4.488	V
Output Current	I_O	$V_{IN}=6.4V$	300	—	—	mA
Dropout Voltage	V_D	$I_{OUT}=100mA, \Delta V_{OUT}=2\%$	—	160	300	mV
Quiescent Current	I_Q	$I_{OUT}=0mA$	—	1.5	3	μA
Line Regulation	$\Delta V_{OUT} / \Delta V_{IN} \cdot V_{OUT}$	$I_{OUT}=1mA$ $5.4V \leq V_{IN} \leq 20V$	—	0.2	—	%/V
Load Regulation	ΔV_{OUT}	$1mA \leq I_{OUT} \leq 300mA$ $V_{IN}=6.4V$	—	37	100	mV
Output Short Current	I_{lim}	$V_{OUT}=0V$	—	400	—	mA
Output Voltage Temperature Coefficient	$\Delta V_{OUT} / \Delta T_A \cdot V_{OUT}$	$I_{OUT}=10mA, V_{IN}=6.4V$ $T_A=-40\sim 85^\circ C$	—	± 100	—	ppm/ $^\circ C$

Note: The dropout voltage is defined as $V_{IN} - V_{OUT}$, when V_{OUT} is 98% of the normal value of V_{OUT} .

● Electrical Characteristics(HR73L50T4/V) (Ta=25°C Unless otherwise specified)

Parameter	Symbol	Conditions	Min.	Typ.	Max.	Unit
Output Voltage	V_{OUT}	$I_{OUT}=10mA, V_{IN}=7V$	4.9	5	5.1	V
Output Current	I_O	$V_{IN}=7V$	300	—	—	mA
Dropout Voltage	V_D	$I_{OUT}=100mA, \Delta V_{OUT}=2\%$	—	150	300	mV
Quiescent Current	I_Q	$I_{OUT}=0mA$	—	1.5	3	μA
Line Regulation	$\Delta V_{OUT} / \Delta V_{IN} \cdot V_{OUT}$	$I_{OUT}=1mA$ $6V \leq V_{IN} \leq 20V$	—	0.2	—	%/V
Load Regulation	ΔV_{OUT}	$1mA \leq I_{OUT} \leq 300mA$ $V_{IN}=7V$	—	37	100	mV
Output Short Current	I_{lim}	$V_{OUT}=0V$	—	400	—	mA
Output Voltage Temperature Coefficient	$\Delta V_{OUT} / \Delta T_A \cdot V_{OUT}$	$I_{OUT}=10mA, V_{IN}=7V$ $T_A=-40\sim 85^\circ C$	—	± 100	—	ppm/ $^\circ C$

Note: The dropout voltage is defined as $V_{IN} - V_{OUT}$, when V_{OUT} is 98% of the normal value of V_{OUT} .

● Functional Description

Input Capacitor

A 10 μ F ceramic capacitor is recommended to connect between V_{IN} and GND pins to decouple input power supply glitch and noise. The amount of the capacitance may be increased without limit. This input capacitor must be located as close as possible to the device to assure input stability and less noise. For PCB layout, a wide copper trace is required for both V_{IN} and GND.

Output Capacitor

An output capacitor is required for the stability of the LDO. The recommended minimum output capacitance is 10 μ F, ceramic capacitor is recommended, and temperature characteristics are X7R or X5R. Higher capacitance values help to improve load/line transient response. The output capacitance may be increased to keep low undershoot/overshoot.

Place output capacitor as close as possible to V_{OUT} and GND pins.

Thermal Considerations

For continuous operation, do not exceed absolute maximum junction temperature. The maximum power dissipation depends on the thermal resistance of the IC package, PCB layout, rate of surrounding airflow, and difference between junction and ambient temperature. The maximum power dissipation can be calculated by the following formula: $P_{D(MAX)} = (T_{J(MAX)} - T_A) / R_{\theta JA}$.

Where $T_{J(MAX)}$ is the maximum operation junction temperature 125 $^{\circ}$ C, T_A is the ambient temperature and the $R_{\theta JA}$ is the junction to ambient thermal resistance. The power dissipation definition in device is: $P_D = (V_{IN} - V_{OUT}) \times I_{OUT} + V_{IN} \times I_Q$

Layout Consideration

By placing input and output capacitors on the same side of the PCB as the LDO, and placing them as close as is practical to the package can achieve the best performance. The ground connections for input and output capacitors must be back to the HR73 Series ground pin using as wide and as short of a copper trace as is practical. Connections using long trace lengths, narrow trace widths, and connections through via must be avoided. These add parasitic inductances and resistance that results in worse performance especially during transient conditions.

● Ratings And Characteristics Curves(HR73L33T4/V) (Ta=25°C Unless otherwise specified)

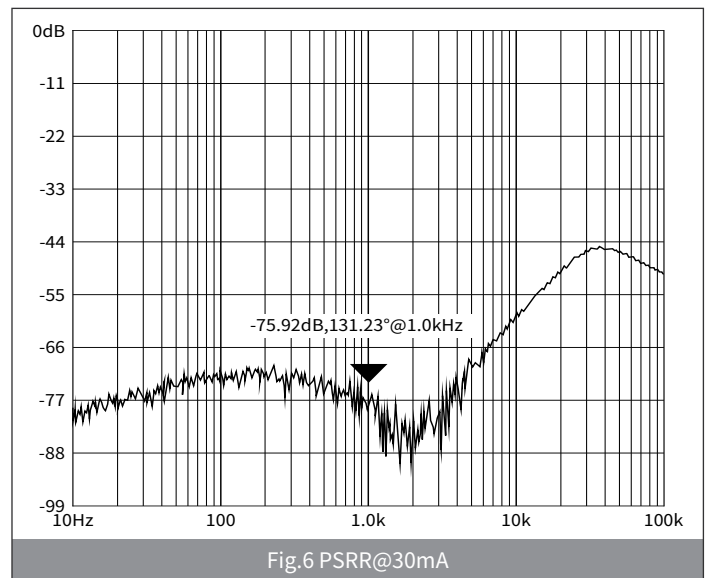
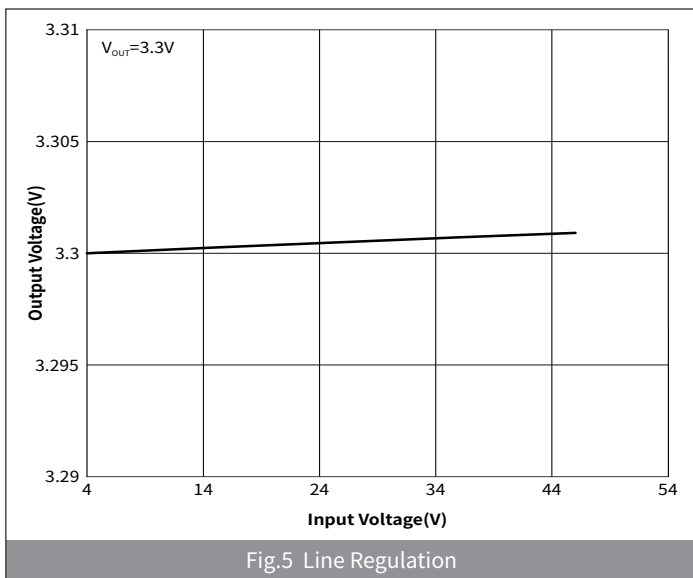
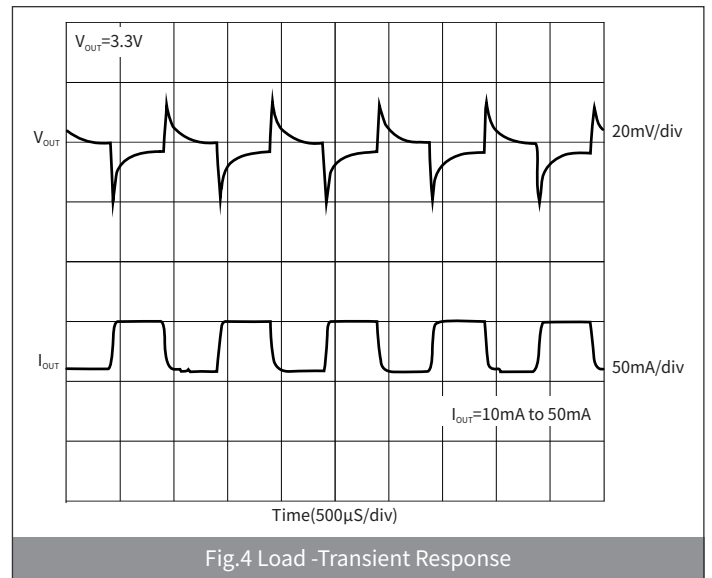
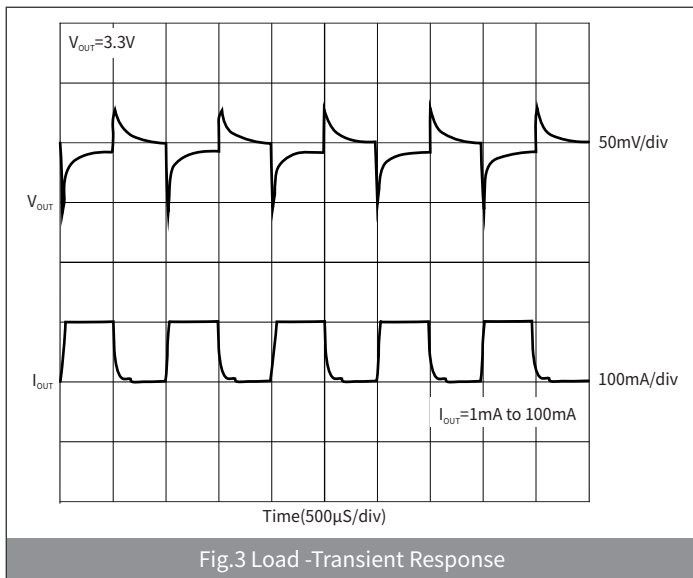
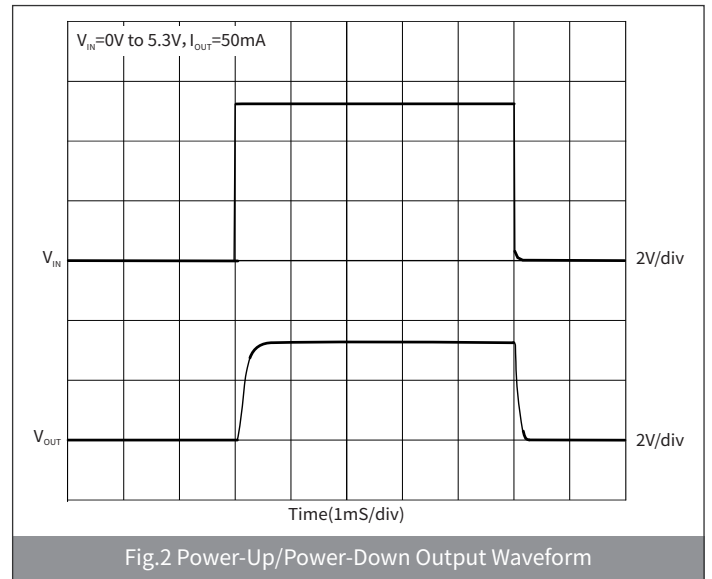
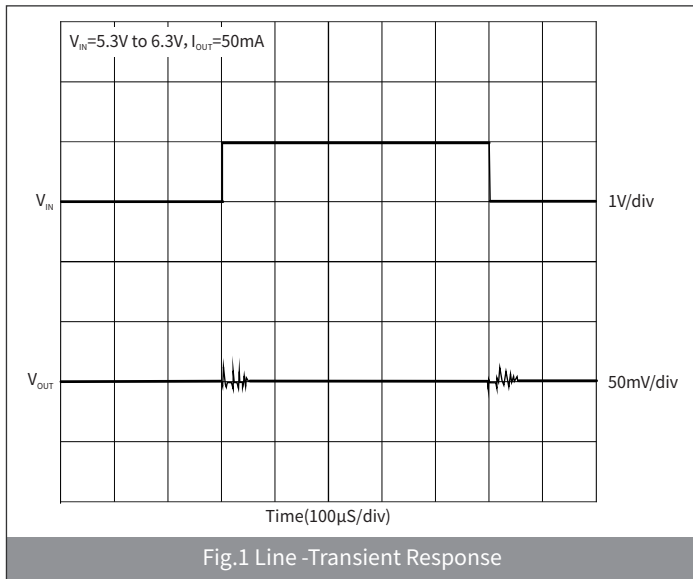

● Package Outline Dimensions (SOT-23-3L)

Symbol	Dimensions			
	Millimeters		Inches	
	Min.	Max.	Min.	Max.
A	1.05	1.25	0.041	0.049
A1	-	0.10	-	0.004
A2	1.05	1.15	0.041	0.045
b	0.30	0.50	0.012	0.020
c	0.10	0.20	0.004	0.008
D	2.82	3.02	0.111	0.119
E	1.50	1.70	0.059	0.067
E1	2.65	2.95	0.104	0.116
e	0.90	1.00	0.035	0.039
e1	1.80	2.00	0.071	0.079
L	0.45	0.65	0.018	0.026
L1	0.30	0.60	0.012	0.024
θ	-	8°	-	8°

● Suggested Pad Layout

Symbol	Dimensions			
	Millimeters		Inches	
	Min.	Max.	Min.	Max.
J	0.80	-	0.031	-
K	-	0.95	-	0.037
M	2.00	-	0.078	-
N	-	2.0	-	0.079

● Package Outline Dimensions (SOT-89)

Symbol	Dimensions			
	Millimeters		Inches	
	Min.	Max.	Min.	Max.
A	4.40	4.60	0.173	0.181
B	1.35	1.83	0.053	0.072
C	3.75	4.25	0.148	0.167
D	2.29	2.60	0.090	0.102
E	2.95	3.05	0.116	0.120
a	0.35	0.48	0.014	0.019
b	0.40	0.56	0.016	0.022
L	0.80	1.20	0.031	0.047
G	0.35	0.44	0.014	0.017
H	1.40	1.60	0.055	0.063

● Suggested Pad Layout

Symbol	Dimensions			
	Millimeters		Inches	
	Min.	Max.	Min.	Max.
c	0.80	1.00	0.032	0.04
d	1.30	1.50	0.052	0.060
e	0.70	0.90	0.028	0.036
J	1.80	2.00	0.072	0.080
K	1.40	1.60	0.056	0.064
X	2.50	2.70	0.100	0.108
X1	1.30	1.50	0.052	0.060
Y	4.30	4.50	0.172	0.180
Y1	3.10	3.30	0.124	0.132
θ	-	45°	-	45°