



福建省长兴电子有限公司

CHANGXING ELECTRONICS CO.,LTD.

福建省将乐县东门新村3号

NO.3 Dong Men New Village Jiangle Country, Fujian

电话: 86-598-2329554 传真: 86-598-2333554

石英晶体谐振器产品确认书

Quartz Crystal Resonator Specification For Approval

产品型号: Model	Glass5032 2PIN 16.000000MHz
客户名称: Customer	_____
客户编号: Customer's Part No.	_____
长兴编号: Product No.	9ASC160G0008L
发行日期: Issue Date	_____

承办: 吴丽萍 审核: 林东国 批准: 杨启付

内容:

- 1、Features 特点
- 2、Electrical Specifications 电气参数
- 3、Dimensions 外型尺寸
- 4、Marking 印码
- 5、Reflow Condition 回流焊条件
- 6、Packing 包装 (EIA-481-2)
- 7、Reliability Specifications (可靠性规范)
- 8、Material Composition Declaration (产品物质成分表)

客户 Conclusion:

Conditional Approval Full Approval Reject

会 签 意 见	
------------------	--

APPROVED BY : _____ ISSUED DATE : _____

5.0x3.2x1.2mm SMD Glass Sealing Crystals / 9A Series

■ Features 特点

- . 2 pads SMD glass sealed crystal units.
- . High reliable environmental performance.
- . Tight tolerance and stability parts are available.
- . Designed for automatic mounting and reflow soldering.
- . Reasonable cost and good delivery performance.
- . The best choice of portable PC, PDA, DSC, and USB interface card.
- . Contains Pb in sealing glass exempted by RoHS directive.

■ Electrical Specifications 电气参数

Standard atmospheric conditions

Unless otherwise specified, the standard range of atmospheric conditions for making measurement and tests are as follow:

Ambient temperatu: $22 \pm 5^{\circ}\text{C}$

Relative humidity : 40%~70%

If there is any doubt about the results, measurement shall be made within the following limits:

Ambient temperatu: $22 \pm 1^{\circ}\text{C}$

Relative humidity : 40%~70%

Measure equipment

Electrical characteristics measured by HP E5100A or equivalent.

Crystal cutting type

The crystal is using AT CUT (thickness shear mode).

	Parameters	Electrical Spec.	UNITS	Notes
1	Nominal Frequency	16.000000	MHz	-
2	Oscillation Mode	Fund	-	-
3	Load Capacitance	8	pF	-
4	Frequency Tolerance	± 10	ppm	at $25^{\circ}\text{C} \pm 3^{\circ}\text{C}$
5	Frequency Stability	± 30	ppm	Over Operating Temp. Range
6	Operating Temperature	-40~+85	$^{\circ}\text{C}$	-
7	Aging		ppm	1st Year
8	Drive Level	100	μW	-
9	Effective Resistance Rr	40 Max.	Ω	-
10	Shunt Capacitance C0	5 Max.	pF	-
11	Motional Capacitance C1	-	fF	-
12	Pulling Sensitivity TS	-	ppm/pF	-
13	Spurious Response	-3.0	dB	-1000~+5000 ppm 125 步
14	Insulation Resistance	500 Min.	M Ω	at DC 100V
15	Storage Temperature Range	-55~+125	$^{\circ}\text{C}$	-
16	RLD2	40 Max.	Ω	0.01~30 μW /15 steps 30~100 μW /5 steps 100~30 μW /5 steps 30~0.01 μW /15 steps
17	FDDL	10 Max.	ppm	
18	DLD2	10 Max.	Ω	
19	FDDLH	5 Max.	ppm	
20	DLDH2	5 Max.	Ω	
21	DLDF	-	Ω	
22	DLD2 (低)	-	Ω	0.01~30 μW /15 steps
23	MSL	Level 1	-	IPC/JEDEC J-STD-033C
24	Others	-	-	-

■ Dimensions外型尺寸

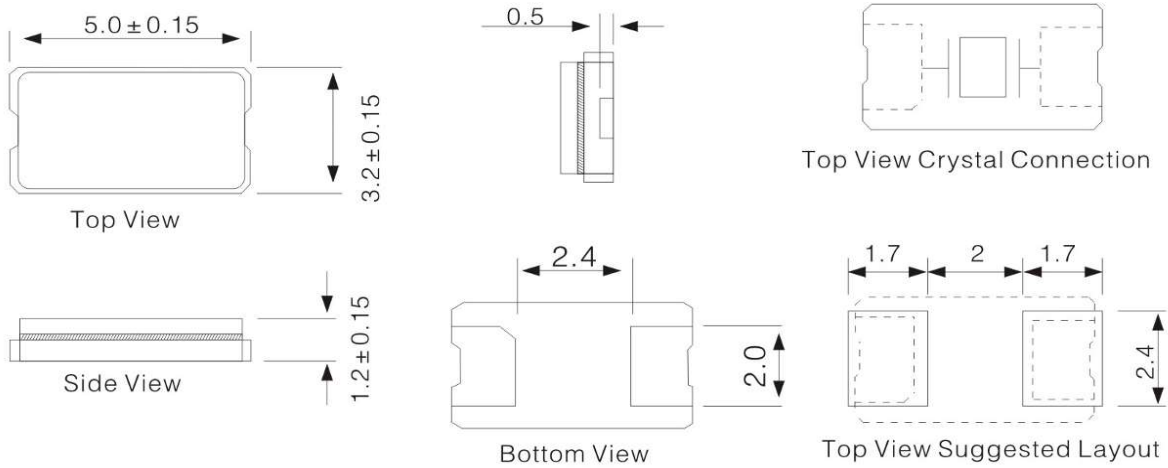

Units:mm

■ Marking印码

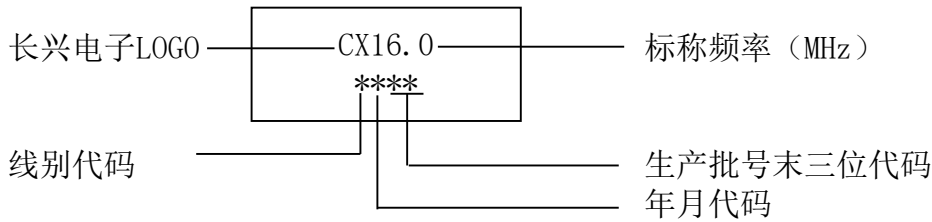

年月代码（四年一个周期）：

年份 \ 月份		一月	二月	三月	四月	五月	六月	七月	八月	九月	十月	十一月	十二月
2023	2027	a	b	c	d	e	f	g	h	j	k	l	m
2024	2028	n	p	q	r	s	t	u	v	w	x	y	z
2025	2029	A	B	C	D	E	F	G	H	J	K	L	M
2026	2030	N	P	Q	R	S	T	U	V	W	X	Y	Z

■ Reflow Condition回流焊条件

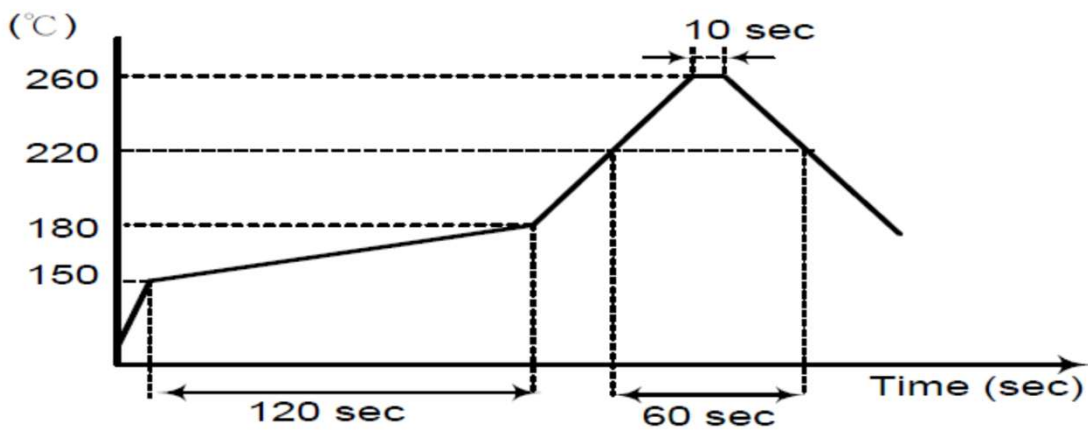

■ Packing包装 (EIA-481-2)

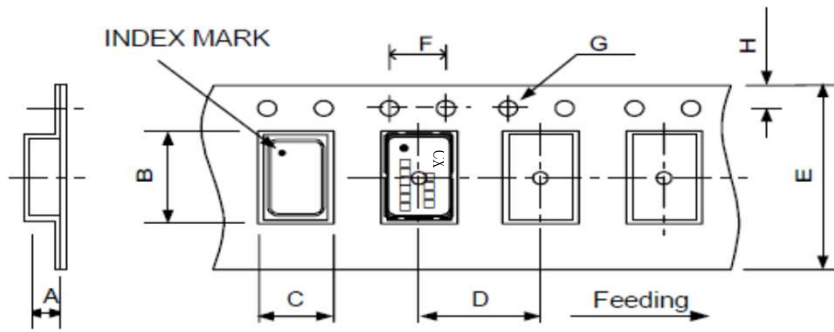

DIMENSIONS	A	B	C	D	E	F	G	H
UNIT : mm	1.45±0.1	5.40±0.1	3.60±0.1	8.00±0.1	12.0±0.2	4.00±0.1	1.55±0.05	1.75±0.1

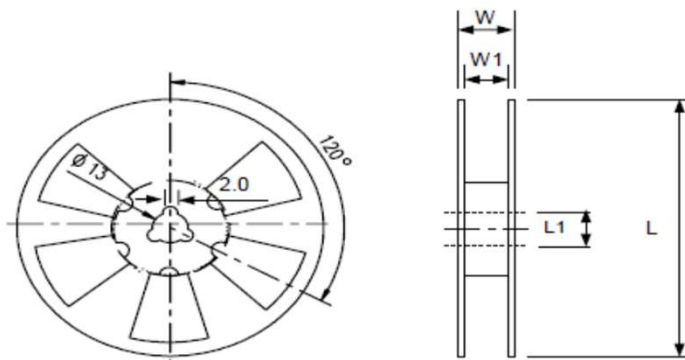
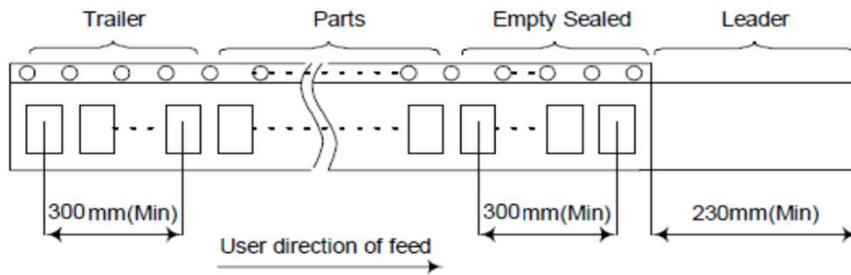

DIMENSIONS	L	L1	W	W1	Standard Reel Quantity
UNIT : mm	180±1.0	13±0.5	16.5±0.2	12.0±1.0	1,000 pcs per reel (WHITE)

■ Reliability Specifications (可靠性规范)

1. Mechanical Endurance (机械耐久性)

No.	Test Item	Test Methods	REF. DOC
1.1	Drop Test	75 cm height, 3 times on concrete floor .	JIS C6701
1.2	Mechanical Shock	Device are shocked to half sine wave (1000 G) three mutually perpendicular axes each 3 times. 0.5m sec. duration time	MIL-STD-202F
1.3	Vibration	Frequency range 10 ~2000 Hz Amplitude 1.52 mm/20G Sweep time 20 minute Perpendicular axes each test time 4 hours (Total test time 12 hours)	MIL-STD-883E
1.4	Gross Leak	Standard Sample For Automatic Gross Leak Detector, Test Pressure: 2Kg / cm ²	MIL-STD-883E
1.5	Fine Leak	Helium Bombing 4.5 Kgf / cm ² for 2 hr	
1.6	Solderability	Temperature 260 °C ± 5°C Immersing depth 0.5 mm minimum Immersion time 5 ± 1 seconds Flux Rosin resin methyl alcohol solvent (1 : 4)	MIL-STD-883E

2. Environmental Endurance (环境耐久性)

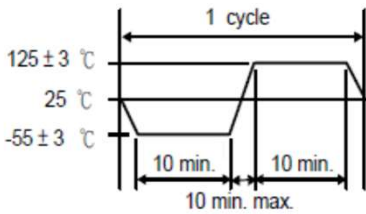
No.	Test Item	Test Methods	REF. DOC
2.1	Resistance To Soldering Heat	Pre-heat temperature 125 °C Pre-heat time 60 ~ 120 sec. Test temperature 260 ± 5 °C Test time 10 ± 1 sec.	MIL-STD-202F
2.2	High Temp. Storage	+ 125 °C ± 3 °C for 1000 ± 12 hours	MIL-STD-883E
2.3	Low Temp. Storage	- 40 °C ± 3 °C for 1000 ± 12 hours	
2.4	Thermal Shock	Total 100 cycles of the following temperature cycle 	MIL-STD-883E
2.5	High Temp&Humidity	85°C ± 3°C , RH 85% , 1000Hrs	JIS C5023

Material Composition Declaration

材料成份表

1.PRODUCTION NAME : Glass 5032

2.PRODUCTION WEIGHT(mg) : 52.850

编号 No.	构成部件 Name of Part	部件材质名 Material Name	材质质量 Material Mass(mg)	材质质量百分比 Material mass (%)	构成之元素名称 Constituent name	CAS编号 CAS No.	元素百分比 Material Analysis(%)				
1	基座 Base	陶瓷 Ceramics	25.446	48.15%	Al ₂ O ₃ Aluminum oxide	1344-28-1	92.41%				
					SiO ₂ Silicon oxide	14808-60-7	4.30%				
					Cr ₂ O ₃ Chromium Oxide	1308-38-9	1.51%				
					MgO Magnesium Oxide	1309-48-4	0.69%				
					CaO Calcium oxide	1305-78-8	1.09%				
		金属化 (Metal)	2.142	4.05%	W Tungsten	7440-33-7	100.00%				
		镀层 (Plating)	0.412	0.78%	Au Gold	7440-57-5	17.69%				
				Ni Nickel	7440-02-0	82.31%					
2	外壳 Cover	陶瓷 Ceramic	15.248	28.85%	Al ₂ O ₃ Aluminum oxide	1344-28-1	84.12%				
					MnO ₂ Manganese oxide	1313-13-9	2.87%				
					SiO ₂ Silicon oxide	14808-60-7	2.87%				
					TiO ₂ Titanium oxide	13463-67-7	5.22%				
					Cr ₂ O ₃ Chromium oxide	1308-38-9	1.91%				
					Fe ₂ O ₃ Iron oxide	1309-37-1	2.06%				
					MgO Magnesium oxide	1309-48-4	0.48%				
					Co ₃ O ₄ Cobalt oxide	1308-06-1	0.48%				
		玻璃胶 Glass	7.702	14.57%	PbO Lead oxide	1317-36-8	57.29%				
					PbF ₂ Lead fluorid	7783-46-2	19.29%				
					Bi ₂ O ₃ Bismuth oxide	1304-76-3	5.30%				
					Nb ₂ O ₅ Niobium oxide	1313-96-8	4.30%				
					B ₂ O ₃ Boron oxide	1303-86-2	2.30%				
					ZnO Zinc oxide	1314-13-2	2.30%				
					CuO Copper oxide	1317-38-0	1.30%				
					CaO Calcium oxide	1305-78-8	0.30%				
					TiO ₂ Titanium oxide	13463-67-7	5.30%				
					Fe ₂ O ₃ Iron oxide	1309-37-1	2.30%				
					黏合剂 Adhesive	金属 Metal	0.340	0.64%	Ag Silver	7440-22-4	75.00%
									晶态二氧化硅	-	5.00%
石油溶剂 Petroleum solvent	-	5.00%									
有机硅树脂 Silicone resin	-	15.00%									
4	Blank	晶片 Quartz	1.500	2.84%	SiO ₂ Silicon oxide	14808-60-7	100.00%				
					5	Electrode	电极 Electrode	0.06	0.11%	Cr Chromium	7440-47-3
Ag silver	7440-22-4	94.44%									