

## GT-2A038F - C N N G3

- Detail**  
F=No flanging no column
- Shell Material**  
C=Copper alloy
- Shell Plated**  
N=Ni
- Housing Colour**  
W=White  
N=Black
- Terminal Plated**  
G0=G/F  
G1=1u"  
G3=3u"  
...

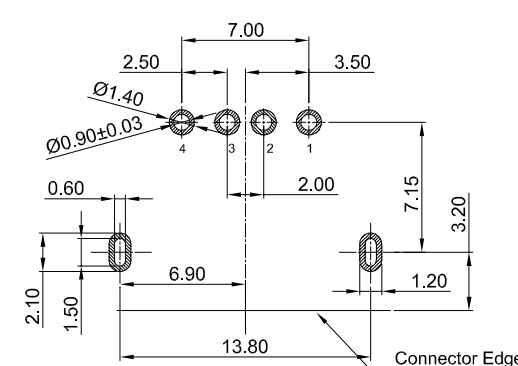
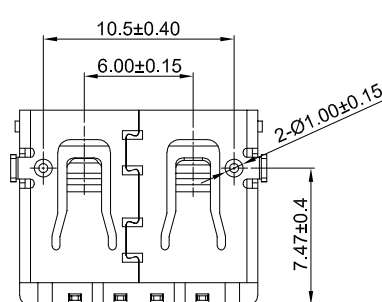
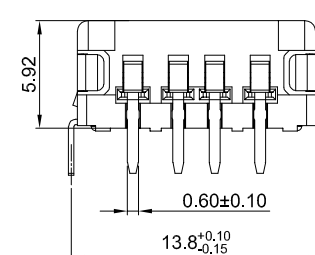
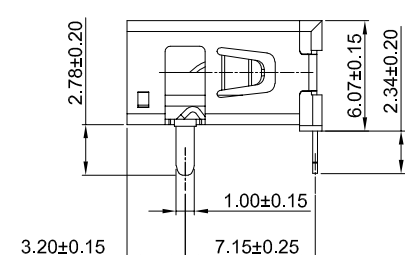
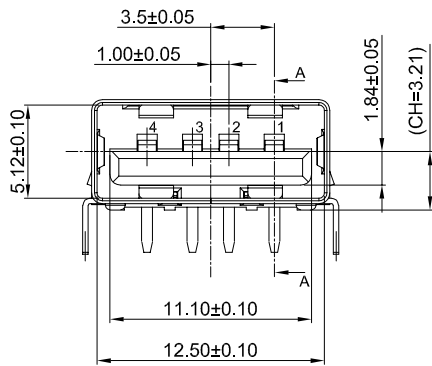

PIN	NAME
4	GND
3	D+
2	D-
1	VBUS

PIN ASSIGNMENT

- G-Switch USB-2.0 Specification:**
1. Current rated: 1.5A
  2. Voltage rating: 30V DC
  3. Dielectric withstanding Voitage: 500V AC
  4. Contact resistance: 30mΩ Max
  5. Insulation resistance: 1000MΩ Min
  6. Operating temperature: -40°C ~ +85°C
  7. Mating force: 35N Max
  8. Unmating force: 10N Min

NO.	PARTS	MATERIAL	REMARKS
1	SHELL	COPPER ALLOY	NI PLATED
2	HOUSING	PBT+30%GF HALOGEN-FREE	BLACK/WHITE UL 94V-0
3	TERMINALS	COPPER ALLOY C5191	Au3u" PLATED ON CONTACT AREA Tin PLATING ON SOLDER AREA



SCALE: 1:1	UNIT: mm	Title: Horizontal USB 2.0 AF DIP CH=3.21 L=10.72mm			
SIZE: A4		Molde Code: GT-2A038F-CNNG3			
Unless otherwise General Tolerance:		DRAWN	CHECKED	APPROVED	DATE
X.x	±0.30	Xla	Chen	Chen	2024.03.10
X.xx	±0.20				
X.x°	±3°				



REV: A0	SHEET: 1/1
---------	------------