

**Harvatek 3.0mm Round IR LED LAMP  
HV-85I3064C**

---

Official Product	HV-85I3064C	Customer Part No.	Data Sheet No.
*	*****	*****	HV-85I3064C
Specifications are subject to change without notice. Data and drawings herein are copyrighted.		May.20 2025	Version of 1.0
			Page 1/12

## DISCLAIMER

HARVATEK reserves the right to make changes without further notice to any products herein to improve reliability, function or design. HARVATEK does not assume any liability arising out of the application or use of any product or circuit described herein; neither does it convey any license under its patent rights, nor the rights of others.

## LIFE SUPPORT POLICY

HARVATEK's products are not authorized for use as critical components in life support devices or systems without the express written approval of the President of HARVATEK or HARVATEK INTERNATIONAL. As used herein:

1. Life support devices or systems are devices or systems which, (a) are intended for surgical implant into the body, or (b) support or sustain life, and (c) whose failure to perform when properly used in accordance with instructions for use provided in the labeling, can be reasonably expected to result in a significant injury of the user.
  
2. A critical component in any component of a life support device or system whose failure to perform can be reasonably expected to cause the failure of the life support device or system, or to affect its safety or effectiveness.

Official Product	HV-85I3064C	Customer Part No.	Data Sheet No.
*	*****	*****	HV-85I3064C
Specifications are subject to change without notice. Data and drawings herein are copyrighted.		May.20 2025	Version of 1.0 Page 2/12

## Compliance and Certification

ISO9002, QS9000 and ISO14001 Certified  
RoHS Compliant



## Orderable Information

**H V - 85 I 3064 C**

Series Name	Color Code	Remark
HV : HARVAT EK	85I: 850nm GaAIAs IR Chip. 3064: 3.0mm Round Lamp, 5.1mm Lens C : Water Clear.	

## Features:

- Stable Color.
- Popular 3.0mm through hole package, 5.1mm lens height.
- Water Clear lens.

Official Product	HV-85I3064C	Customer Part No.	Data Sheet No.
*	*****	*****	HV-85I3064C
Specifications are subject to change without notice. Data and drawings herein are copyrighted.		May.20 2025	Version of 1.0
			Page 3/12

## Package Dimensions:

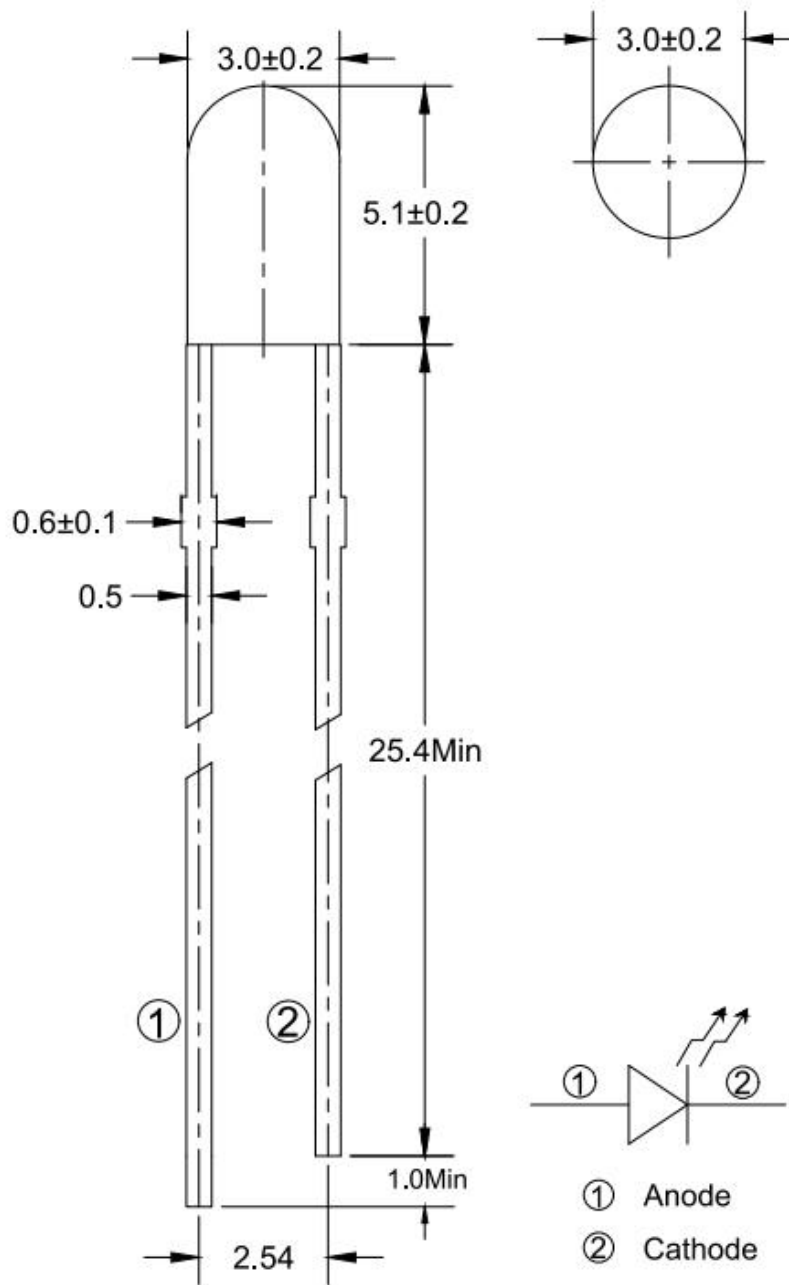

### Notes:

1. All dimensions are millimeters.
2. Tolerance is  $\pm 0.25 \text{ mm}$  unless otherwise noted.
3. Specifications are subject to change without notice.

Official Product	HV-85I3064C	Customer Part No.	Data Sheet No.
*	*****	*****	HV-85I3064C
Specifications are subject to change without notice. Data and drawings herein are copyrighted.		May.20 2025	Version of 1.0
			Page 4/12

**Absolute Maximum Ratings at Ta=25°C**

Parameter	Symbol	Rating	Unit
Forward Current	IF	100	mA
Operating Temperature	Topr	-40to+85	°C
Storage Temperature	Tstg	-40to+85	°C
Soldering Temperature*1	Tsol	260	°C
Power Dissipation	Pd	150	mW
Reverse Voltage	VR	5	V
Peak Forward Current*2	IFp	500	mA

\*1:Soldering time  $\leq$  5 seconds. \*2:Pulse Width  $\leq$  100 $\mu$ s and Duty  $\leq$  1%.

Official Product	HV-85I3064C	Customer Part No.	Data Sheet No.
*	*****	*****	HV-85I3064C
Specifications are subject to change without notice. Data and drawings herein are copyrighted.		May.20 2025	Version of 1.0
			Page 5/12

## Electrical and Optical Characteristic

Parameter	Symbol	Condition	Min.	Typ.	Max.	Unit
Forward Voltage	$V_F$	$I_F=20\text{ mA}$	/	1.4	1.6	V
Reverse Current	$I_R$	$V_R=5\text{ V}$	/	/	100	$\mu\text{A}$
Radiant intensity	$I_e$	$I_F=20\text{mA}$	7.8	16	/	mW/sr
Viewing Angle	$2\theta_{1/2}$	$I_F=20\text{mA}$	/	25	/	deg
Peak Wavelength	$\lambda_p$	$I_F=20\text{mA}$	/	850	/	nm
Spectrum Radiation Bandwidth	$\Delta\lambda$	$I_F=20\text{mA}$	/	40	/	nm

Official Product	HV-85I3064C	Customer Part No.	Data Sheet No.
*	*****	*****	HV-85I3064C
Specifications are subject to change without notice. Data and drawings herein are copyrighted.		May.20 2025	Version of 1.0
			Page 6/12

**Specifications for Bin Grading:**

Ie (mW/sr)		
Grade	Min.	Max.
M	7.8	12.50
N	11.00	17.60
P	15.00	24.00
Q	21.00	34.00

Notes: :Radiant intensity: +/-15%.

Official Product	HV-85I3064C	Customer Part No.	Data Sheet No.
*	*****	*****	HV-85I3064C
Specifications are subject to change without notice. Data and drawings herein are copyrighted.		May.20 2025	Version of 1.0
			Page 7/12

**Typical Electro-Optical Characteristics Curve**

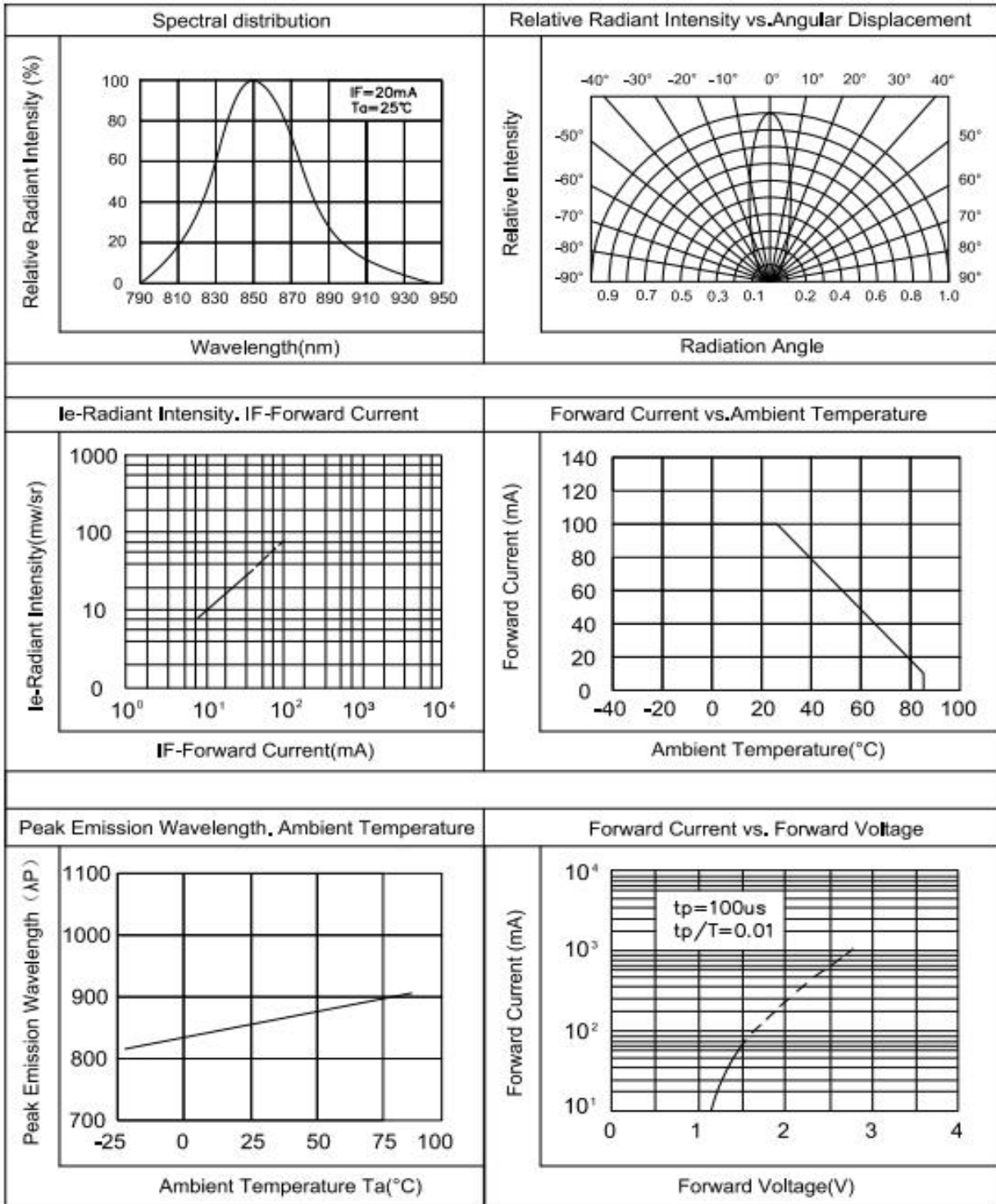

Official Product	HV-85I3064C	Customer Part No.	Data Sheet No.
*	*****	*****	HV-85I3064C
Specifications are subject to change without notice. Data and drawings herein are copyrighted.		May.20 2025	Version of 1.0
			Page 8/12

## Soldering condition

1. Careful attention should be paid during soldering. When soldering, leave more than 2mm from solder joint to Led, and soldering beyond the base of the tie bar is recommended.
2. Avoiding applying any stress to the lead frame while the LED are at high temperature particularly when soldering.
3. Dip and hand soldering should not be done more than one time.
4. After soldering the LED, the epoxy bulb should be protected from mechanical shock or vibration until the LED return to room temperature.
5. A rapid-rate process is not recommended for cooling the LED down from the peak temperature.
6. Although the recommended soldering conditions are specified in the above table, dip or hand soldering at the lowest possible temperature is desirable for the LED.
7. Wave soldering parameter must be set and maintain according to recommended temperature and dwell time in the solder wave.

## Recommended soldering conditions

Hand Soldering		Wave Soldering	
Temp. at tip of iron	300°C Max. (30W Max.)	Preheat temp.	100°C Max. (60 sec Max.)
Soldering time	3 sec Max.	Bath temp. & time	260°C Max., 5 sec Max
Distance	2mm Min. (From solder joint to Led)	Distance	2mm Min. (From solder joint to Led)

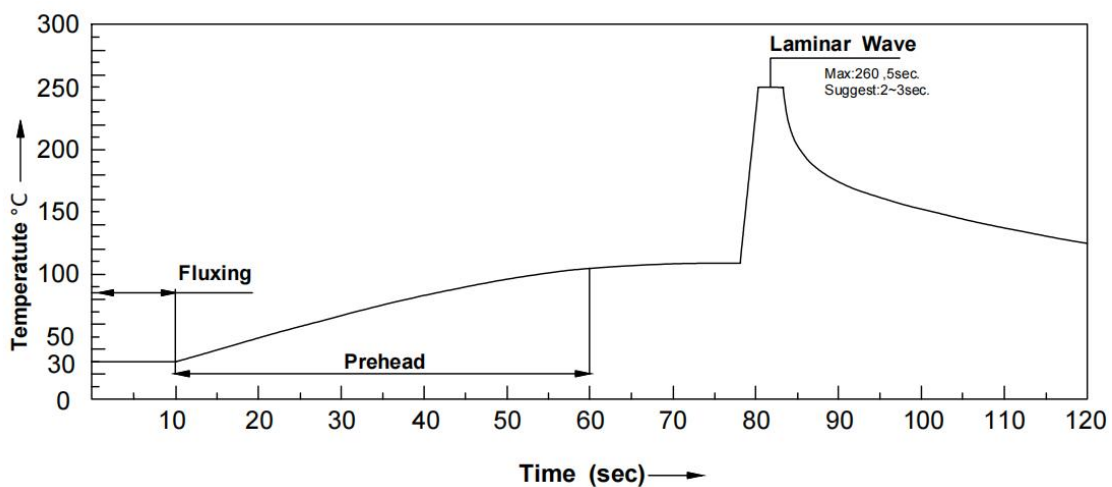

Official Product	HV-85I3064C	Customer Part No.	Data Sheet No.
*	*****	*****	HV-85I3064C
Specifications are subject to change without notice. Data and drawings herein are copyrighted.		May.20 2025	Version of 1.0
			Page 9/12

## Reliability test items and conditions:

The reliability of products shall be satisfied with items listed below.

Confidence level: 97%.

LTPD:3%.

No	Item	Test Conditions	Test Hours/Cycle	Sample Size	Failure Judgment Criteria	Ac/Er
1	Solder Heat	TEMP:260°C±5°C	10 SEC	76 PCS	$I_e \leq I_{et} * 0.5$ or $V_f \geq U$ or $V_f \leq L$	0/1
2	Temperature Cycle	H:+100°C 15min ∫ 5min L:-40°C 15min	300 CYCLES	76 PCS		0/1
3	Thermal Shock	H:+100°C 5min ∫ 10sec L:-10°C 5min	300 CYCLES	76 PCS		0/1
4	High Temperature Storage	TEMP:100°C	1000 HRS	76 PCS		0/1
5	Low Temperature Storage	TEMP:-40°C	1000 HRS	76 PCS		0/1
6	DC Operating Life	TEMP:25°C IF=20mA	1000 HRS	76 PCS		0/1
7	High Temperature / High Humidity	85°C/85%RH	1000 HRS	76 PCS		0/1

Note:  $I_{et}$ : To test  $I_e$  value of the chip before the reliability test.

$I_e$ : The test value of the chip that has completed the reliability test.

U: Upper Specification Limit.

L: Lower Specification Limit.

Official Product	HV-85I3064C	Customer Part No.	Data Sheet No.
*	*****	*****	HV-85I3064C
Specifications are subject to change without notice. Data and drawings herein are copyrighted.		May.20 2025	Version of 1.0
			Page 10/12

## Packing Specification:

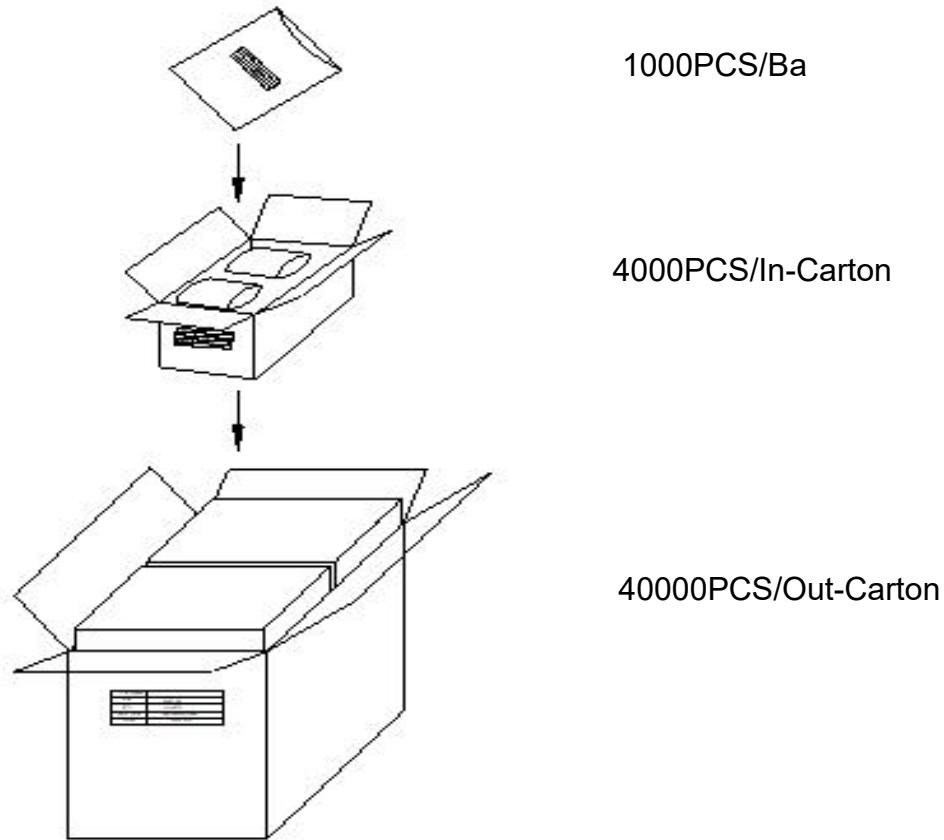

	<b>HARVATEK</b>	
CPN:		<b>RoHs</b>
P/N:		
	<b>HV-85I3064C</b>	
QTY:		CAT:
		HUE:
LOT NO:		REF:

Official Product	HV-85I3064C	Customer Part No.	Data Sheet No.
*	*****	*****	HV-85I3064C
Specifications are subject to change without notice. Data and drawings herein are copyrighted.		May.20 2025	Version of 1.0
			Page 11/12

**Revision History**

Revision	Page	Version No.	Revision Date
Initial Release		1.0	05-20-2025

Official Product	HV-85I3064C	Customer Part No.	Data Sheet No.
*	*****	*****	HV-85I3064C
Specifications are subject to change without notice. Data and drawings herein are copyrighted.		May.20 2025	Version of 1.0
			Page 12/12