

1000mA Linear Voltage Regulators

● Features

- Quiescent Current: 5mA
- Input Voltage Range: 15V
- Output Current: 1000mA
- Low Dropout Voltage: 1.3V@1A
- Output Voltage: 1.25V, 1.8V, 2.5V, 3.3V, 5.0V
- Operation Ambient Temperature: -40~85° C

● Applications

- PC Motherboard
- LCD Monitor
- Graphic Card
- Modem
- Printer

● General Description

The HR1117 Series are low-dropout three-terminal Linear regulators with a dropout of 1.15V(typ.) at 1A output current. They are divided into two versions, fixed voltage output version and adjustable voltage output version; The fixed output voltage is 1.2V, 1.8V, 2.5V, 3.3V, 5V and the adjustable version can provide the output voltage from 1.25V to 12V with only 2 external resistors.

● Reference News

SOT-89 Marking:

HR1117V-ADJ: 1117-ADJ
HR1117V-1.8: 1117-1.8
HR1117V-2.5: 1117-2.5
HR1117V-3.3: 1117-3.3
HR1117V-5.0: 1117-5.0

SOT-223 Marking:

HR1117T-ADJ: 1117-ADJ
HR1117T-1.8: 1117-1.8
HR1117T-2.5: 1117-2.5
HR1117T-3.3: 1117-3.3
HR1117T-5.0: 1117-5.0

● Part Numbering

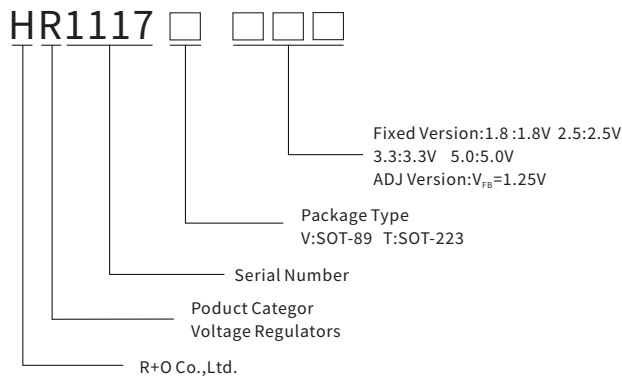

● Ordering Information

Package	Package Code	Unit Weight(g)	Reel(pcs)	Box(pcs)	Carton(pcs)	Delivery Mode	MSL
SOT-89	R1	0.045	1000	8000	48000	7"	3
SOT-223	R3	0.231	3000	6000	30000	13"	3

Output Current
1000mA
Input Voltage
15V

SOT-89

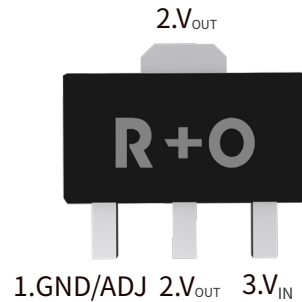

SOT-223

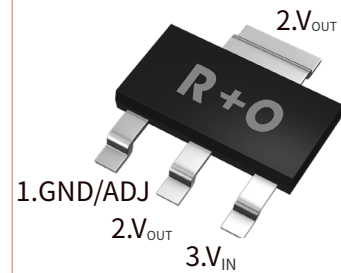

● Block Diagram

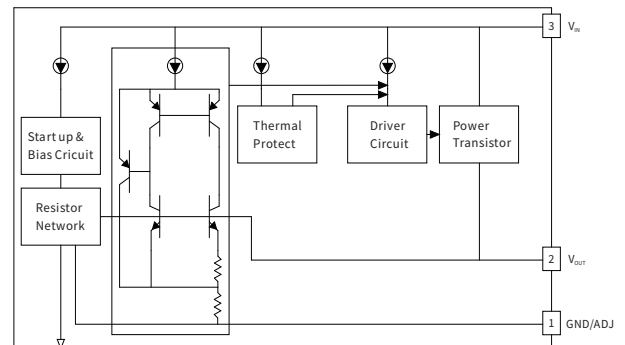

● Typical Application Circuit

Fixed Output Voltage Version

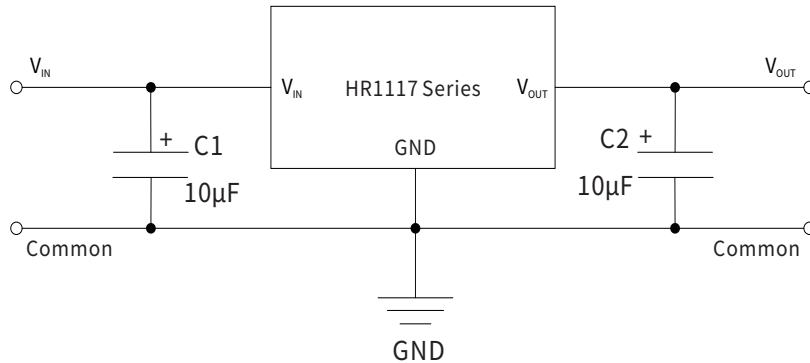

Adjustable Fixed Output Voltage Version

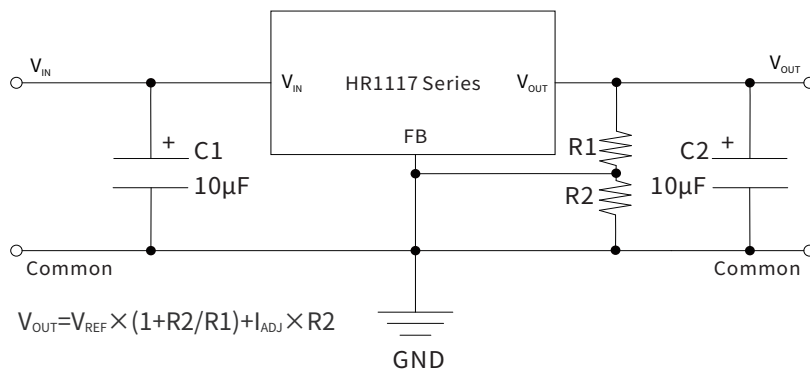

The output voltage of adjustable version follows the equation: $V_{OUT} = 1.25 \times (1 + R2/R1) + I_{ADJ} \times R2$. We can ignore I_{ADJ} because I_{ADJ} (approximately 50µA) is much less than the current of R1 (approximately 2~10mA).

(1). To meet the minimum load current (>10mA) requirement, R1 is recommended to be 125Ω or lower. As HR1117XX-ADJ can keep itself stable at load current about 2mA, R1 is not allowed to be higher than 625Ω.

(2). Using a bypass capacitor (C_{ADJ}) between the FB pin and ground can improve ripple rejection. This bypass capacitor prevents ripple from being amplified as the output voltage is increased. The impedance of C_{ADJ} should be less than R1 to prevent ripple from being amplified. As R1 is normally in the range of 100Ω~500Ω, the value of C_{ADJ} should satisfy this equation: $1 / (2\pi \times \text{fripple} \times C_{ADJ}) < R1$.

● Absolute Maximum Ratings (Ta=25°C Unless otherwise specified)⁽¹⁾⁽²⁾

Parameter	Symbol	Value	Unit
Input Voltage Limit	V_{IN}	15	V
Operating Current	I_O	1000	mA
Thermal Resistance Junction-Ambient	$R_{\theta JA}$	100	°C/W
Solder Temperature/Time	T_d	260/10	°C/S
Operating Ambient Temperature	T_A	+85	°C
Junction and Storage Temperature	T_J, T_{stg}	-40~+125	°C

● **Electrical Characteristics** ($V_i \leq 10V$ $T_j=25^\circ C$ Unless otherwise specified)

Parameter	Symbol	Part No.	Conditions	Min.	Typ.	Max.	Unit
Reference Voltage	V_{RO}	1117-ADJ	$I_{OUT}=10mA, V_{IN}-V_{OUT}=2V$	1.23	1.25	1.269	V
			$10mA \leq I_{OUT} \leq 1A$ $1.4V \leq V_{IN}-V_{OUT} \leq 12V$	1.225	1.25	1.275	
Output Voltage	V_{OUT}	1117-1.8	$I_{OUT}=10mA, V_{IN}=3.8V$	1.773	1.8	1.827	V
			$10mA \leq I_{OUT} \leq 1A$ $3.2V \leq V_{IN} \leq 12V$	1.764	1.8	1.836	
		1117-2.5	$I_{OUT}=10mA, V_{IN}=4.5V$	2.463	2.5	2.538	
			$10mA \leq I_{OUT} \leq 1A$ $4V \leq V_{IN} \leq 12V$	2.45	2.5	2.55	
		1117-3.3	$I_{OUT}=10mA, V_{IN}=5V$	3.254	3.3	3.35	
			$10mA \leq I_{OUT} \leq 1A$ $5V \leq V_{IN} \leq 12V$	3.234	3.3	3.366	
		1117-5.0	$I_{OUT}=10mA, V_{IN}=7V$	4.925	5.0	5.075	
			$10mA \leq I_{OUT} \leq 1A$ $7V \leq V_{IN} \leq 12V$	4.9	5.0	5.1	
Line Regulation	LNR	1117-ADJ	$I_{OUT}=10mA$ $1.5V \leq V_{IN}-V_{OUT} \leq 12V$	—	0.03	0.2	%
		1117-1.8	$I_{OUT}=10mA$ $1.5V \leq V_{IN}-V_{OUT} \leq 10.2V$		1	7	mV
		1117-2.5	$I_{OUT}=10mA$ $1.5V \leq V_{IN}-V_{OUT} \leq 9.5V$		1	7	
		1117-3.3	$I_{OUT}=10mA$ $1.5V \leq V_{IN}-V_{OUT} \leq 8.7V$		1	7	
		1117-5.0	$I_{OUT}=10mA$ $1.5V \leq V_{IN}-V_{OUT} \leq 7V$		1	10	
Load Regulation	LDR	1117-ADJ	$10mA \leq I_{OUT} \leq 1A$ $V_{IN}-V_{OUT}=1.5V$	—	0.2	0.4	%
		1117-1.8		—	—	7.2	mV
		1117-2.5		—	—	10	
		1117-3.3		—	—	13.2	
		1117-5.0		—	—	20	
Dropout Voltage	V_D	HR1117 Series	$I_{OUT}=1A, \Delta V_R=1\%$	—	1.1	1.3	V
Quiescent Current	I_Q	HR1117 Series	$V_{IN}=V_{OUT}+1.25$	—	2	5	mA
Min Load Current	I_L	HR1117 Series	$V_{IN}=5V, V_{adj}=0V$	—	—	7	mA
Adjust Pin Current	I_{adj}	HR1117 Series	$I_{OUT}=10mA$	—	—	120	uA
Adjust Current Change	ΔI_{adj}	HR1117 Series	$I_{OUT}=10mA$ $1.5V \leq V_{IN}-V_{OUT} \leq 12V$	—	—	5	uA
Temperature Stability	HR1117 Series			—	0.5	—	%
Long-Term Stability	HR1117 Series		$TA=125^\circ C$ 1000hrs	—	0.3	—	%
RMS Output Noise (% of V_{OUT})	HR1117 Series		$TA=125^\circ C$	—	0.003	—	%
Thermal Shutdown Hysteresis	HR1117 Series			—	25	—	$^\circ C$

Note:

(1) These are stress ratings only. Stresses exceeding the range specified under Absolute Maximum Ratings may cause substantial damage to the device. Functional operation of this device at other conditions beyond those listed in the specification is not implied and prolonged exposure to extreme conditions may affect device reliability.

(2) The Power Dissipation is : $P_D=(T_{J(MAX)}-T_C)/R_{\theta JC}$.

● Ratings And Characteristics Curves (Ta=25°C Unless otherwise specified)

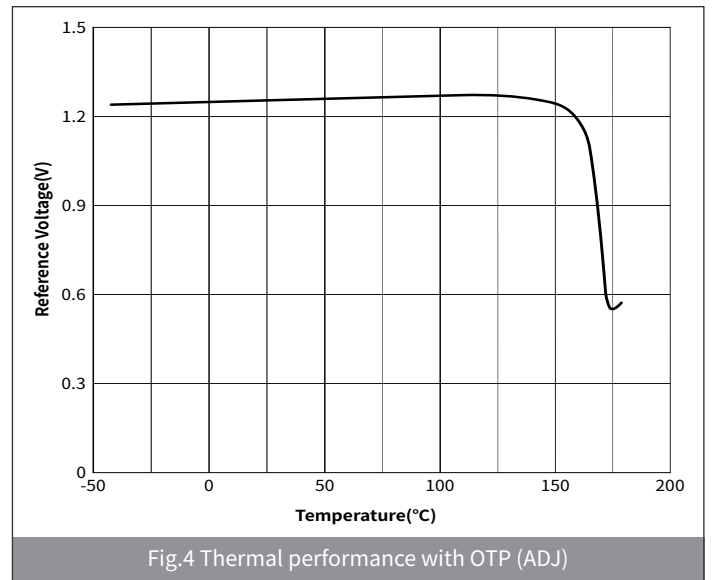
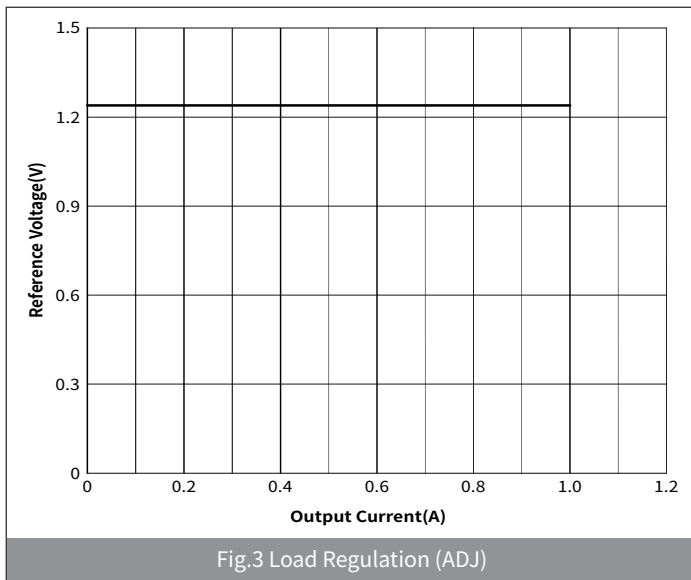
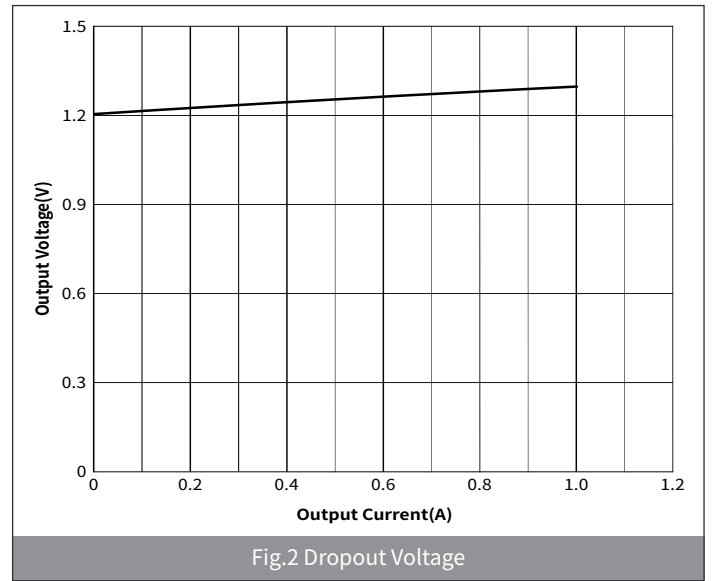
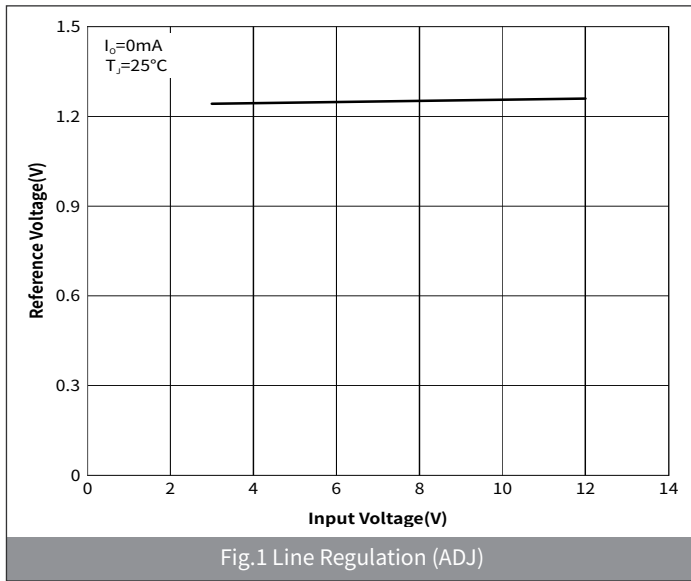

● Package Outline Dimensions (SOT-89)

Symbol	Dimensions			
	Millimeters		Inches	
	Min.	Max.	Min.	Max.
A	4.40	4.60	0.173	0.181
B	1.35	1.83	0.053	0.072
C	3.75	4.25	0.148	0.167
D	2.29	2.60	0.090	0.102
E	2.95	3.05	0.116	0.120
a	0.35	0.48	0.014	0.019
b	0.40	0.56	0.016	0.022
L	0.80	1.20	0.031	0.047
G	0.35	0.44	0.014	0.017
H	1.40	1.60	0.055	0.063

● Suggested Pad Layout

Symbol	Dimensions			
	Millimeters		Inches	
	Min.	Max.	Min.	Max.
c	0.80	1.00	0.032	0.04
d	1.30	1.50	0.052	0.060
e	0.70	0.90	0.028	0.036
J	1.80	2.00	0.072	0.080
K	1.40	1.60	0.056	0.064
X	2.50	2.70	0.100	0.108
X1	1.30	1.50	0.052	0.060
Y	4.30	4.50	0.172	0.180
Y1	3.10	3.30	0.124	0.132
θ	-	45°	-	45°

● Package Outline Dimensions (SOT-223)

Symbol	Dimensions			
	Millimeters		Inches	
	Min.	Max.	Min.	Max.
A	-	1.8	-	0.071
A1	0.020	0.100	0.001	0.004
A2	1.50	1.700	0.059	0.067
b	0.660	0.840	0.026	0.033
b1	2.900	3.100	0.114	0.122
c	0.230	0.350	0.009	0.014
D	6.300	6.700	0.248	0.264
E	6.700	7.300	0.264	0.287
E1	3.300	3.700	0.130	0.146
e	2.300(BSC)		0.091TYP	
L	0.750	-	0.030	-
θ	0°	10°	0°	10°

● Suggested Pad Layout

Symbol	Dimensions			
	Millimeters		Inches	
	Min.	Max.	Min.	Max.
J	3.20	3.60	0.126	0.142
K	1.40	1.80	0.055	0.071
M	5.90	6.30	0.23	0.25
N	2.15	2.45	0.085	0.096
O	0.60	0.85	0.024	0.033