

1 2 3 4 5 6 7 8 9 10 11 12

NO.	ECN NO.	DESCRIPTION	DATE
1			

客户图

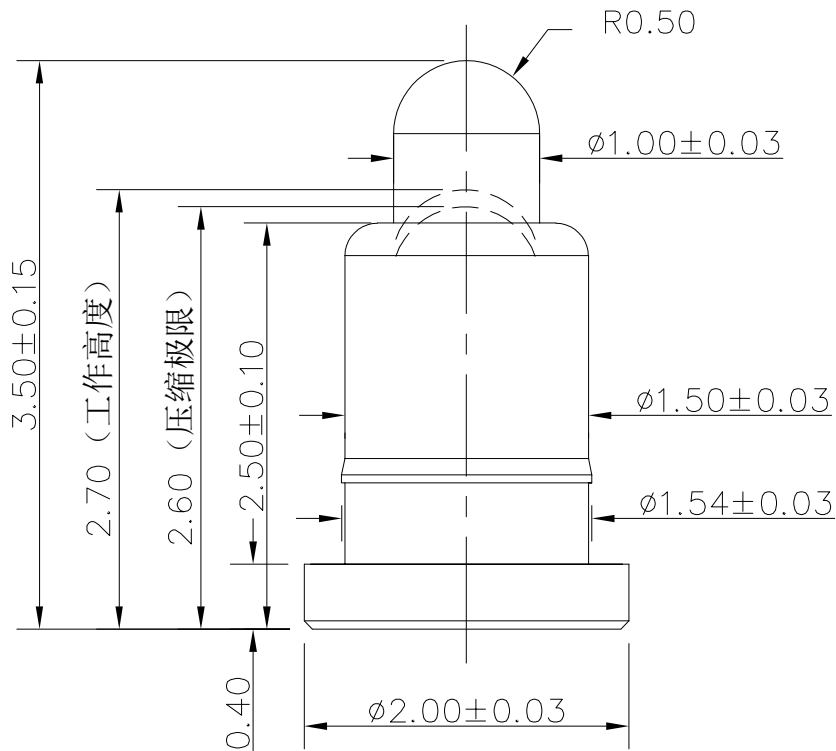

Note:

- Material(材料):
 Barrel: stainless steel SUS 304 (针管: 不锈钢SUS304)
 Plunger: Brass C3604 (针头: 黄铜 C3604)
 Spring: SUS304 (弹簧: SUS304)
- Plating(电镀):
 Barrel: 3u' Au over 50~80u' Ni(针管: 镀金3u', 镍底50~80u'.)
 Plunger: 3u' Au over 50~80u' Ni (针头: 镀金3u', 镍底50~80u'.)
 Spring: Gold flash (弹簧: 镀金)
- Electrical(电气特性):
 Rated Current & Voltage: DC 12V;1A (额定电压&电流: 直流12V,1A)
 Contact Resistance: 100 mohm Max. at working height.
 接触电阻: 最大100毫欧 (在工作高度状态下)
- Mechanical(机械性能):
 Force: 120g±20% at working height. (120g±20% 在工作高度)。)
 Durability: 10.000 cycles(min) (寿命: 10000次)
- WorkTemperture(工作环境):
 Withstanding Higt Temperature: 280℃
 Operational Temperature: -20℃~ +70℃

深圳市鑫探技术有限公司

HTTP://WWW.XYZPOGOPIN.COM

TEL:0755-28773277 FAX:0755-28891353



SCALE:	N/A	UNIT	mm
SHEET:	1 of 1	PROJECTION	
DATE:	2024.07.19	VER.	A-1

THE UNMARKED TOLERANCE ARE AS BELOW :			
LENGTH		ANGLE	
X.XX	±0.05mm	X.XX	±0.50°
X.X	±0.10mm	X.X	±1.00°
X.	±0.20mm	X.	±2.00°

DESIGNED BY:		DWG. NO.	YZ00315035R-14
CHECKED BY:		TITLE:	Pogo Pin
APPROVED BY:			

1 2 3 4 5 6 7 8 9 10 11 12