

General Description

The CMS4946A uses advanced trench technology and design to provide excellent RDS(ON).

It can be used in a wide variety of applications.

Features

- Low On-Resistance
- Simple Drive Requirements
- Dual MOSFET in surface mount package
- RoHS Compliant

Absolute Maximum Ratings

Symbol	Parameter	Rating	Units
V_{DS}	Drain-Source Voltage	60	V
V_{GS}	Gate-Source Voltage	± 20	V
$I_D@T_C=25^\circ C$	Continuous Drain Current	5	A
$I_D@T_C=100^\circ C$	Continuous Drain Current	3.5	A
I_{DM}	Pulsed Drain Current	20	A
EAS	Single Pulse Avalanche Energy ¹	18	mJ
$P_D@T_C=25^\circ C$	Total Power Dissipation	2	W
T_{STG}	Storage Temperature Range	-55 to 150	$^\circ C$
T_J	Operating Junction Temperature Range	-55 to 150	$^\circ C$

Thermal Data

Symbol	Parameter	Typ.	Max.	Unit
$R_{\theta JA}$	Thermal Resistance, Junction-to-Ambient	---	62.5	$^\circ C/W$
$R_{\theta JC}$	Thermal Resistance Junction -Case	---	34	$^\circ C/W$

Product Summary

BVDSS	$R_{DS(on)}$ max.	ID
60V	44mΩ	5A

Applications

- Power switching application
- Hard Switched and High Frequency Circuits
- Uninterruptible Power Supply

SOP-8 Pin Configuration

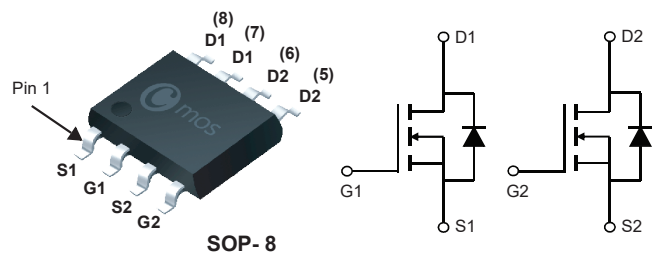

Type	Package	Marking
CMS4946A	SOP- 8	CMS4946A

Electrical Characteristics (T_J=25°C , unless otherwise noted)

Symbol	Parameter	Conditions	Min.	Typ.	Max.	Unit
BV _{DSS}	Drain-Source Breakdown Voltage	V _{GS} =0V , I _D =250μA	60	---	---	V
R _{DS(ON)}	Static Drain-Source On-Resistance	V _{GS} =10V , I _D =5A	---	36	44	mΩ
		V _{GS} =4.5V , I _D =2.5A	---	41	50	
V _{GS(th)}	Gate Threshold Voltage	V _{GS} =V _{DS} , I _D =250μA	1	---	3	V
I _{DSS}	Drain-Source Leakage Current	V _{DS} =60V , V _{GS} =0V	---	---	1	uA
I _{GSS}	Gate-Source Leakage Current	V _{GS} = ±20V , V _{DS} =0V	---	---	±100	nA
g _{fs}	Forward Transconductance	V _{DS} =5V , I _D =2.5A	---	6.6	---	S
R _g	Gate Resistance	V _{DS} =0V , V _{GS} =0V , f=1MHz	---	1.1	---	Ω
Q _g	Total Gate Charge	V _{DS} =30V , V _{GS} =10V , I _D =5A	---	12	---	nC
Q _{gs}	Gate-Source Charge		---	1.8	---	
Q _{gd}	Gate-Drain Charge		---	2.8	---	
T _{d(on)}	Turn-On Delay Time	V _{DD} =30V , V _{GEN} =10V , R _L =6.8Ω R _G =1Ω , I _D ≥4.4A	---	7	---	ns
T _r	Rise Time		---	3.3	---	
T _{d(off)}	Turn-Off Delay Time		---	23	---	
T _f	Fall Time		---	2	---	
C _{iss}	Input Capacitance	V _{DS} =25V , V _{GS} =0V , f=1MHz	---	680	---	pF
C _{oss}	Output Capacitance		---	50	---	
C _{rss}	Reverse Transfer Capacitance		---	30	---	

Diode Characteristics

Symbol	Parameter	Conditions	Min.	Typ.	Max.	Unit
I _S	Continuous Source Current	V _G =V _D =0V , Force Current	---	---	5	A
I _{SM}	Pulsed Source Current		---	---	20	A
V _{SD}	Diode Forward Voltage	V _{GS} =0V , I _S =1A , T _J =25°C	---	0.76	1.2	V

Note :

1.The EAS data shows Max. rating . The test condition is V_{DD}=30V , V_{GS}=10V , L=0.5mH , I_{AS}=8.5A.

This product has been designed and qualified for the consumer market.
Cmos assumes no liability for customers' product design or applications.
Cmos reserves the right to improve product design ,functions and reliability without notice.Please refer to the latest version of specification.

Typical Characteristics

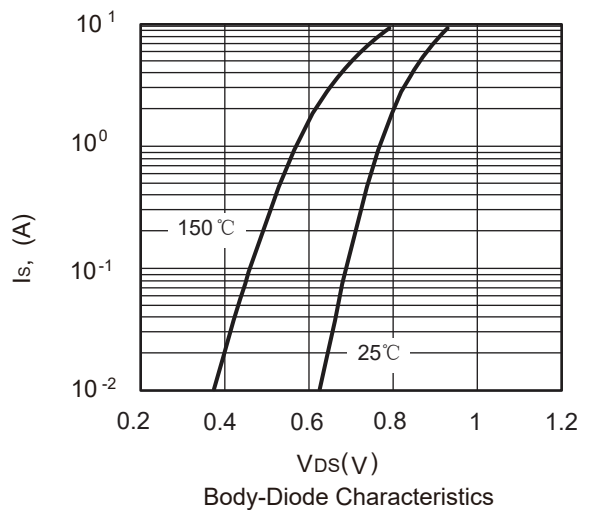
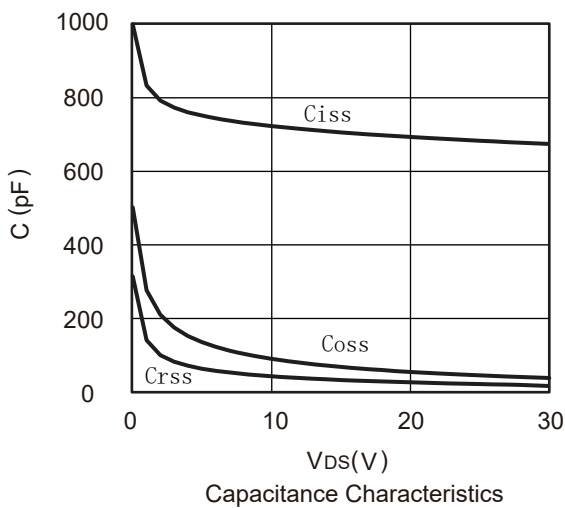
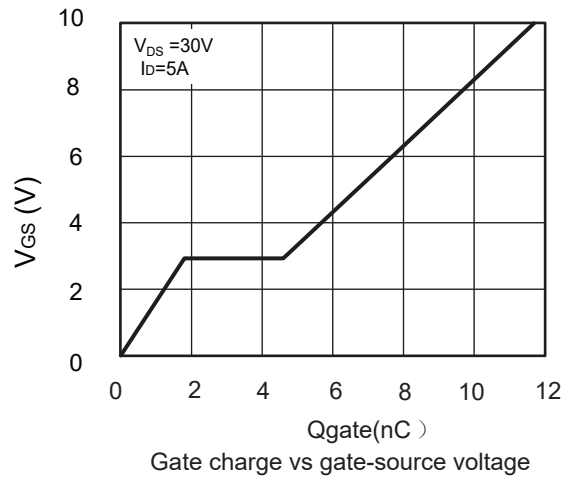
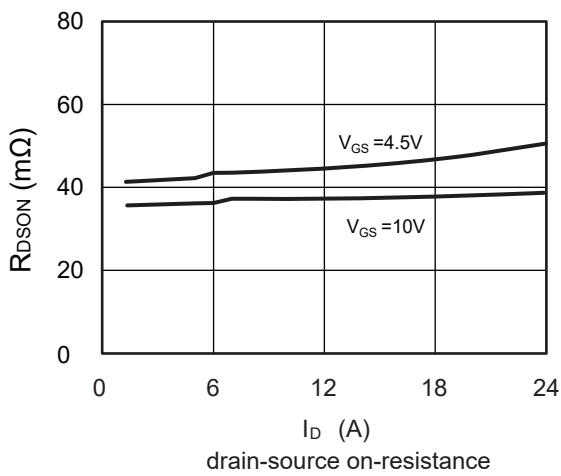
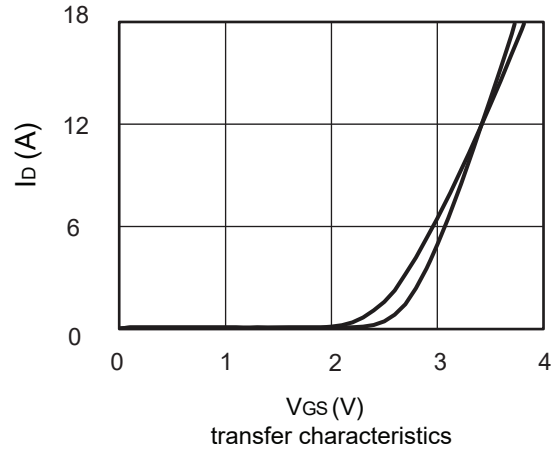
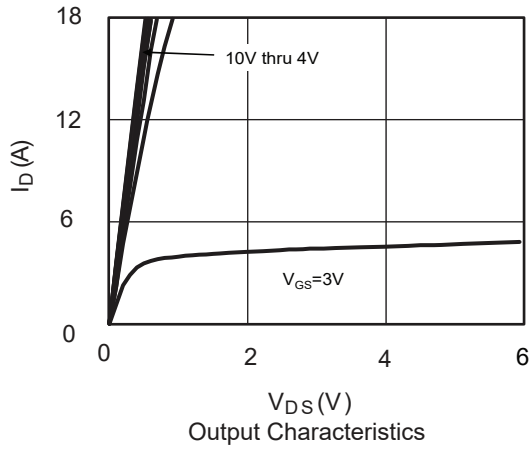

Package Dimension

SOP-8

Unit :mm

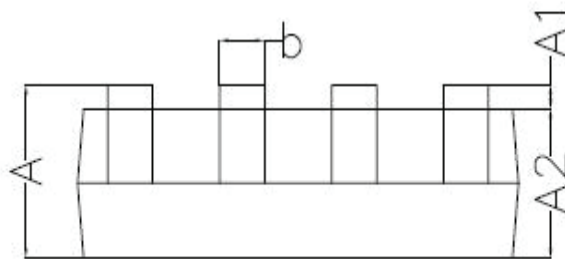
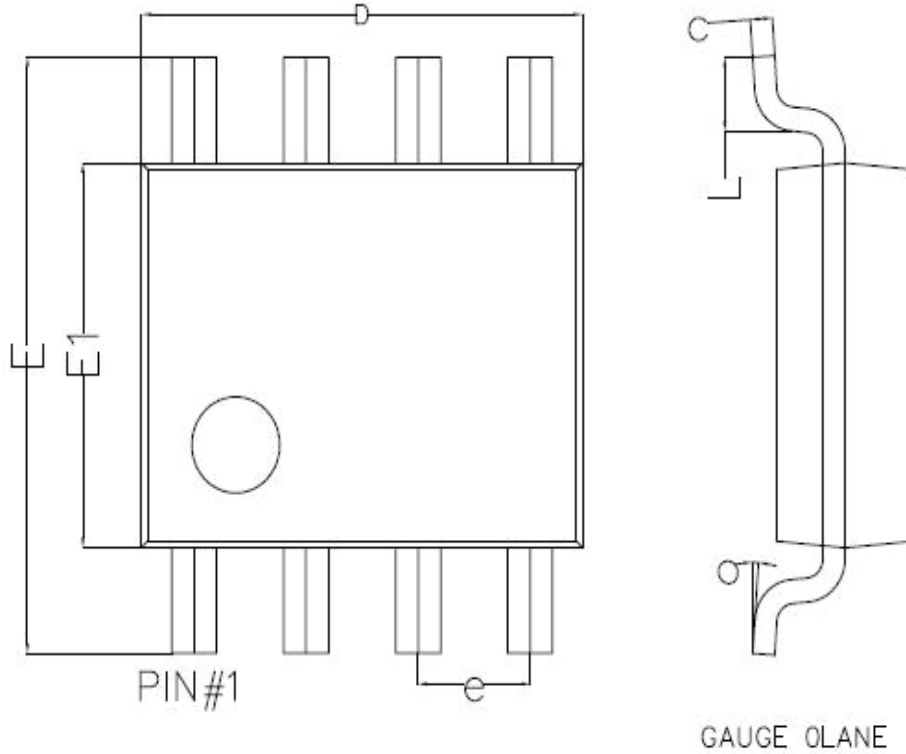

Symbol	Dim in mm		
	Min	Nor	Max
A	1.35	1.55	1.75
A1	0.02	0.065	0.10
A2	1.35	1.45	1.55
b	0.33	0.42	0.51
c	0.17	0.21	0.25
D	4.80	4.90	5.00
e	1.270 (BSC)		
E	5.80	6.00	6.20
E1	3.80	3.90	4.00
L	0.4	0.835	1.27
θ	0°	4°	8°