

NO.	ECN NO.	DESCRIPTION	DATE
1		首次发行	2014.05.23

客户图

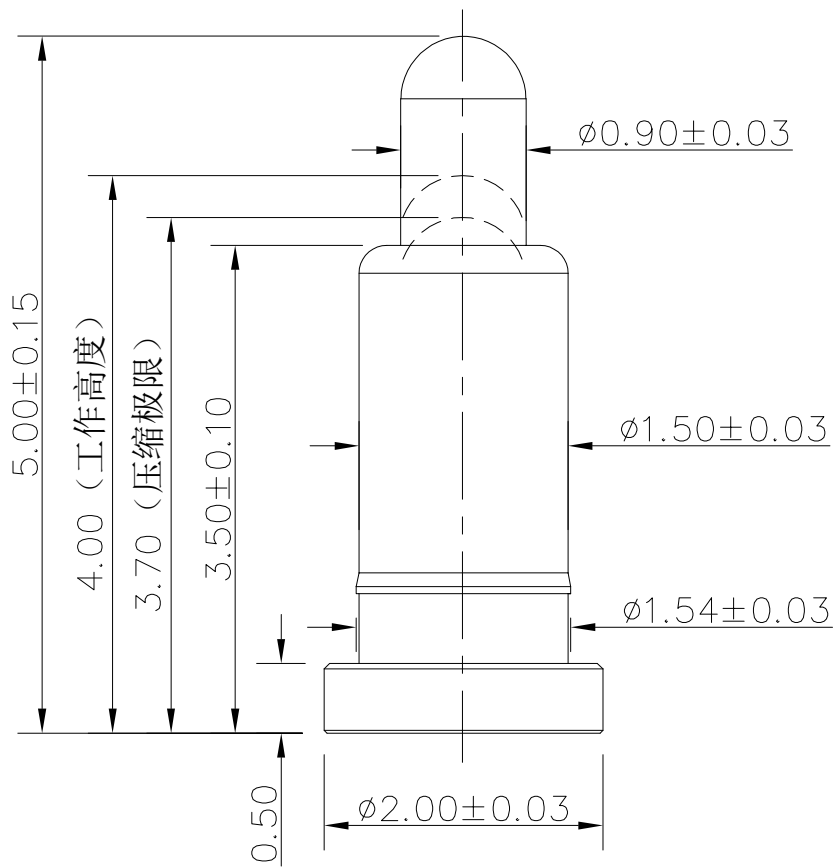

Note:

- Material(材料):
 Barrel: Brass C3604 (针管: 黄铜 C3604)
 Plunger: Brass C3604 (针头: 黄铜 C3604)
 Spring: SUS304 (弹簧: SUS304)
- Plating(电镀):
 Barrel: 3u' Au over 50~80u' Ni(针管: 镀金3u', 镍底50~80u'.)
 Plunger: 3u' Au over 50~80u' Ni (针头: 镀金3u', 镍底50~80u'.)
 Spring: Gold flash (弹簧: 镀金)
- Electrical(电气特性):
 Rated Current & Voltage: DC 12V;1A (额定电压&电流: 直流12V,1A)
 Contact Resistance: 50 mohm Max. at working height.
 接触电阻: 最大50毫欧 (在工作高度状态下)
- Mechanical(机械性能):
 Force: 120g±20% at working height. (120g±20% 在工作高度)。
 Durability: 10.000 cycles(min) (寿命: 10000次)
- WorkTemperture(工作环境):
 Withstanding Higt Temperature: 280℃
 Operational Temperature: -20℃~ +70℃

深圳市鑫扬泽电子有限公司



HTTP://WWW.XYZPOGOPIN.COM
 TEL:0755-28773277 FAX:0755-28891353

SCALE:	N/A	UNIT	mm
SHEET:	1 of 1	PROJECTION	
DATE:	2014.05.23	VER.	A.0

THE UNMARKED TOLERANCE ARE AS BELOW :			
LENGTH		ANGLE	
X.XX	±0.05mm	X.XX	±0.50°
X.X	±0.10mm	X.X	±1.00°
X.	±0.20mm	X.	±2.00°

DESIGNED BY:		DWG. NO.	YZ00615050R-02
CHECKED BY:		TITLE:	Pogo pin
APPROVED BY:			