

RECOMMEND PCB LAYOUT  
TOLERANCE: ±0.05  
TOP VIEW

**MATERIALS**

- HOUSING : HI.-TEMP.PLASTIC(UL 94V-0), BLACK.
- TERMINAL : COPPER ALLOY,  
PLATING : GOLD PLATED ON CONTACT AREA,  
TIN PLATED ON SOLDER TAILS.  
NICKEL PLATED OVERALL.
- SHELL : COPPER ALLOY,  
PLATING : NICKEL PLATED OVERALL.
- EMI SHIELD : STEEL.

**SPECIFICATION**

- CURRENT RATING : 0.5 A. MAX.
- DIELECTRIC WITHSTANDING VOLTAGE :  
500V AC R.M.S. FOR 1 MINUTE.
- INSULATION RESISTANCE : 100MΩ MIN.AT 500V DC.
- CONTACT RESISTANCE : 30mΩ MAX.
- OPERATING TEMPERATURE : -25°C TO +85°C.
- INSERTION FORCE : 4.5Kgf MAX.
- WITHDRAWING FORCE : 1Kgf ~ 4Kgf.



深圳市华宇创精密电子有限公司

<b>TOLERANCE:</b> X.X ±0.30 X.XX ±0.25 X.XXX ±0.15 X' ±2' X.X' ±0.5'	<b>DRAWN BY :</b> 陈一鸣	<b>DATE :</b> 2014-02-23	<b>PART NAME:</b> HDMI2.1 A TYPE 卧式SMT 脚长1.7
	<b>CHECKED BY:</b> 马跃	<b>DATE :</b> 2014-02-23	<b>PART NO.</b> HYCW192-HDMI19-170B <b>MOLD NO.</b>
	<b>APPROVED BY:</b> 邱敏	<b>DATE :</b> 2014-02-23	<b>DRAW NO:</b> HYC-2603301045 <b>SHEET NO.</b> 1 OF 1
<b>UNIT:</b> mm [inch] <b>SCALE:</b> 1:1 <b>SIZE:</b> A4			

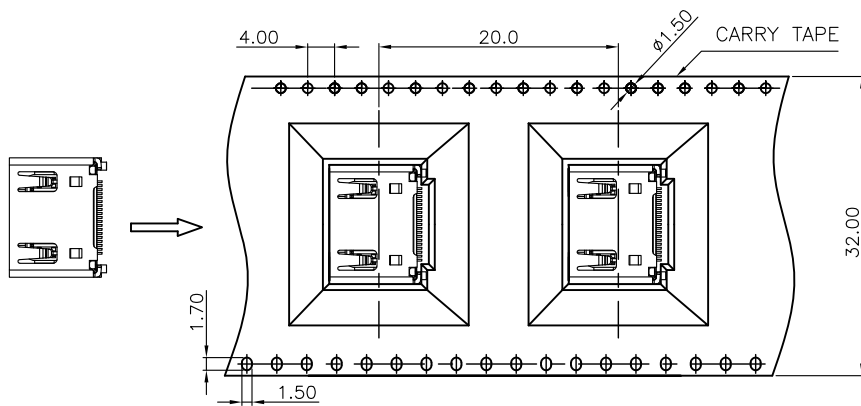
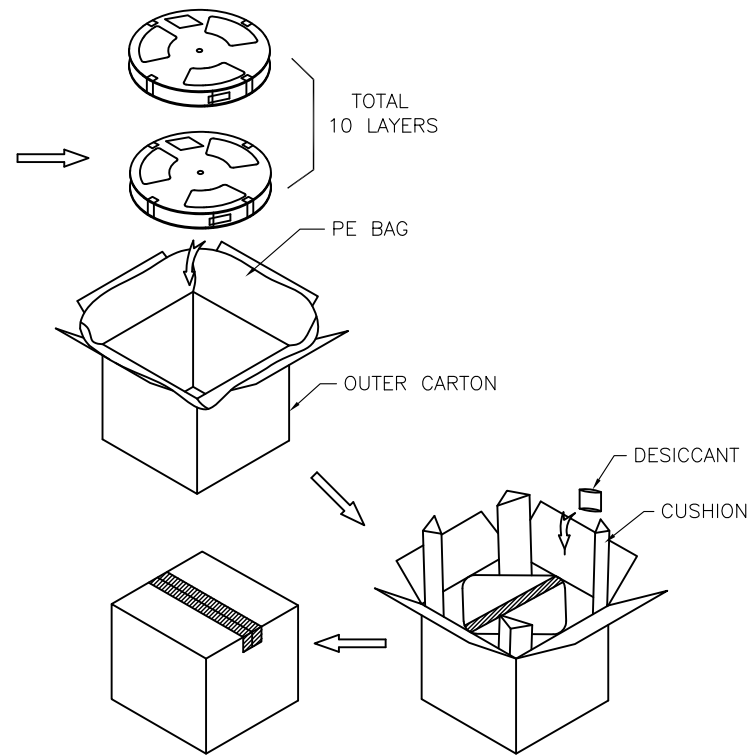
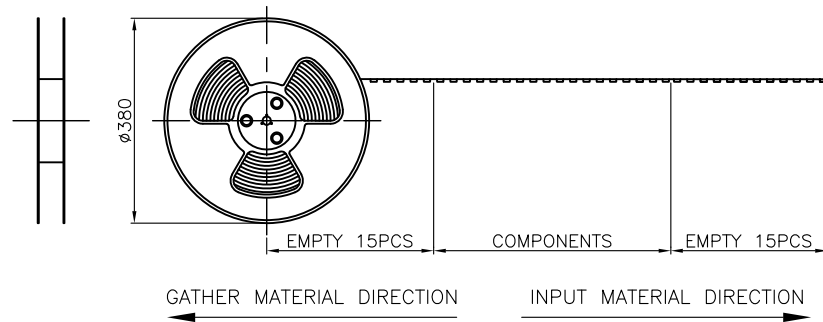

PACKAGE :

1. CORTON SIZE: 400x400x400mm (LxWxH)
2. 500 PCS/REEL
3. 10 REEL/CARTON = 5000PCS



深圳市华宇创精密电子有限公司

TOLERANCE: X.X ±0.30 X.XX ±0.25 X.XXX ±0.15 X.' ±2' X.X' ±0.5'	DRAWN BY : 陈一鸣	DATE : 2014-02-23	PART NAME: 包装图	
	CHECKED BY: 马跃	DATE : 2014-02-23	PART NO.	
UNIT: mm [inch] SCALE:1:1 SIZE: A4	APPROVED BY: 邱敏	DATE : 2014-02-23	MOLD NO.	
			DRAW NO:	
			SHEET NO.	1 OF 1