

CMP65R450/CMB65R450/CMI65R450/CMF65R450



650V, 0.38Ω typ., 11A N-Channel Super Junction Power MOSFET

General Description

The 65R450 is power MOSFET using Cmos's advanced super junction technology that can realize very low on resistance and gate charge. It will provide much high efficiency by using optimized charge coupling technology. These user friendly devices give an advantage of low EMI to designers as well as low switching loss.

Features

- Multi-layer Epitaxial Chip Technology
- Low On-Resistance
- 100% Avalanche Tested
- RoHS Compliant

Product Summary

BV _{DSS}	R _{DS(on)} max.	I _D
650V	0.45Ω	11A

Applications

- Charger
- Adaptor
- Power Supply

TO-220/263/262/220F Pin Configuration

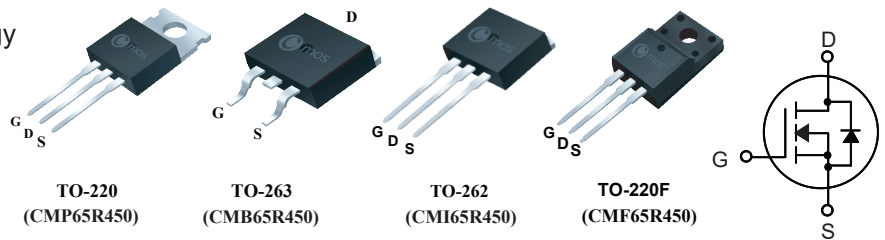

Absolute Maximum Ratings

Symbol	Parameter	220/263/262	220F	Units
V _{DS}	Drain-Source Voltage	650		V
V _{GS}	Gate-Source Voltage	±30		V
I _D @T _C =25°C	Continuous Drain Current	11	11*	A
I _D @T _C =100°C	Continuous Drain Current	7	7*	A
I _{DM}	Pulsed Drain Current	44	44*	A
EAS	Single Pulse Avalanche Energy (Note 1)	303		mJ
P _D @T _C =25°C	Total Power Dissipation	150	40	W
T _{STG}	Storage Temperature Range	-55 to 150		°C
T _J	Operating Junction Temperature Range	-55 to 150		°C

* Drain current limited by maximum junction temperature.

Thermal Data

Symbol	Parameter	220/263/262	220F	Unit
R _{θJA}	Thermal Resistance Junction-ambient Max.	68	68	°C/W
R _{θJC}	Thermal Resistance Junction-case Max.	0.83	3.13	°C/W

Electrical Characteristics (T_J=25°C , unless otherwise noted)

Symbol	Parameter	Conditions	Min.	Typ.	Max.	Unit
BV _{DSS}	Drain-Source Breakdown Voltage	V _{GS} =0V , I _D =250uA	650	---	---	V
R _{DS(ON)}	Static Drain-Source On-Resistance	V _{GS} =10V , I _D =5.5A	---	0.38	0.45	Ω
V _{GS(th)}	Gate Threshold Voltage	V _{GS} =V _{DS} , I _D =250uA	3	4	5	V
I _{DSS}	Drain-Source Leakage Current	V _{DS} =650V , V _{GS} =0V , T _J =25°C	---	---	1	uA
		V _{DS} =650V , V _{GS} =0V , T _J = 150°C	---	10	---	
I _{GSS}	Gate-Source Leakage Current	V _{GS} = ±30V , V _{DS} =0V	---	---	±100	nA
g _{fs}	Forward Transconductance	V _{DS} =20V , I _D = 5A	---	9	---	S
R _g	Gate Resistance	V _{DS} =0V , V _{GS} =0V , f=1MHz	---	3	---	Ω
Q _g	Total Gate Charge	I _D = 5.5A V _{DS} = 480V V _{GS} = 10V	---	22	---	nC
Q _{gs}	Gate-Source Charge		---	5.3	---	
Q _{gd}	Gate-Drain Charge		---	8.8	---	
T _{d(on)}	Turn-On Delay Time	V _{DS} = 400V V _{GS} = 10V I _D = 5.5A R _G = 25Ω	---	20	---	ns
T _r	Rise Time		---	15	---	
T _{d(off)}	Turn-Off Delay Time		---	74	---	
T _f	Fall Time		---	43	---	
C _{iss}	Input Capacitance	V _{DS} =100V , V _{GS} =0V , f=1MHz	---	870	---	pF
C _{oss}	Output Capacitance		---	40	---	
C _{rss}	Reverse Transfer Capacitance		---	5	---	

Diode Characteristics

Symbol	Parameter	Conditions	Min.	Typ.	Max.	Unit
I _S	Continuous Source Current	V _{GS} =V _{DS} =0V , Force Current	---	---	11	A
I _{SM}	Pulsed Source Current		---	---	44	A
V _{SD}	Diode Forward Voltage	V _{GS} =0V , I _F =11A , T _J =25°C	---	0.87	1.5	V
t _{rr}	Reverse Recovery Time	V _{DS} = 100V , T _J = 25°C I _{sd} =5.5A , di/dt=100A/μs	---	218	---	ns
Q _{rr}	Reverse Recovery Charge		---	2.35	---	uC

Note :

1. The EAS data shows Max. rating . The test condition is V_{DD}=80V , V_{GS}=10V , L=30mH , I_{AS} =4.5A.

This product has been designed and qualified for the consumer market.

Cmos assumes no liability for customers' product design or applications.

Cmos reserves the right to improve product design ,functions and reliability without notice. Please refer to the latest version of specification.

Typical Characteristics

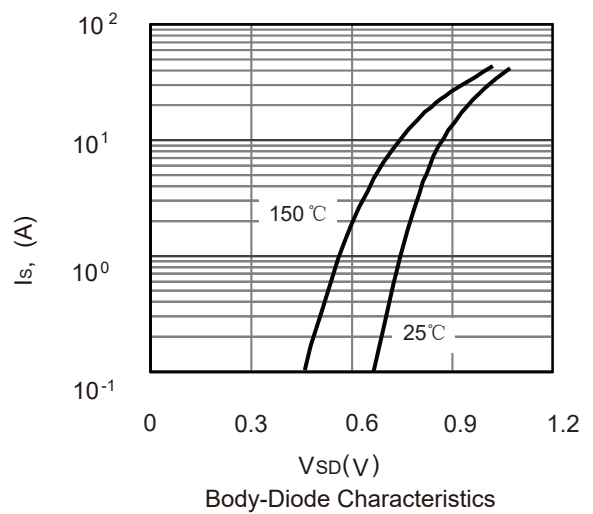
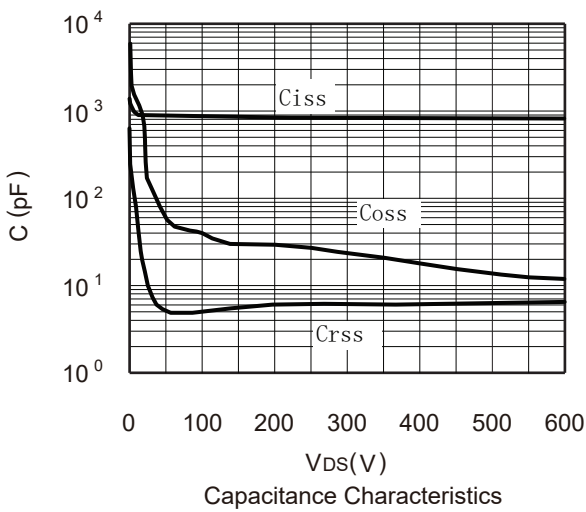
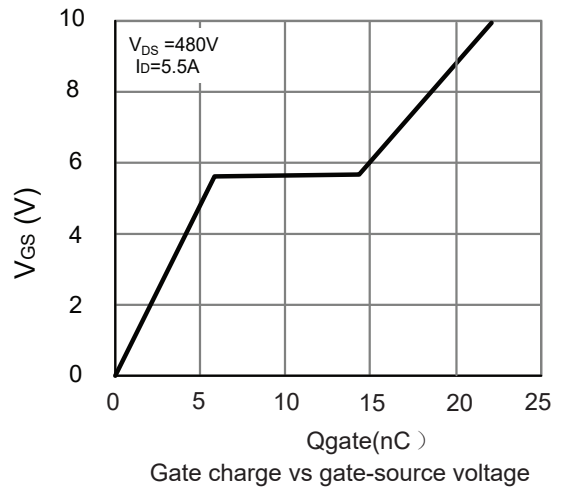
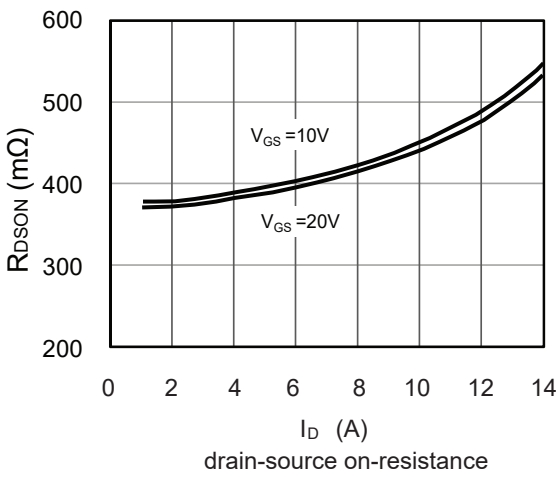
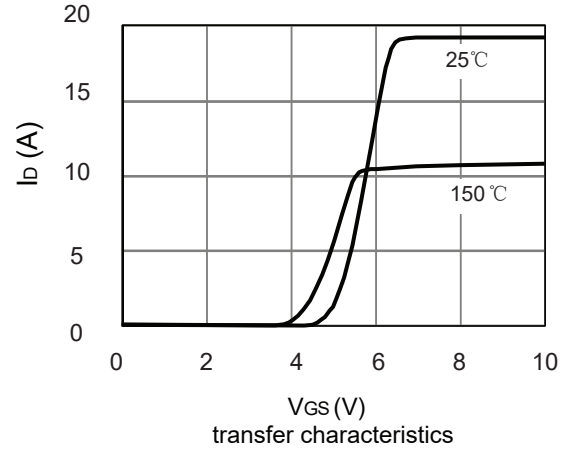
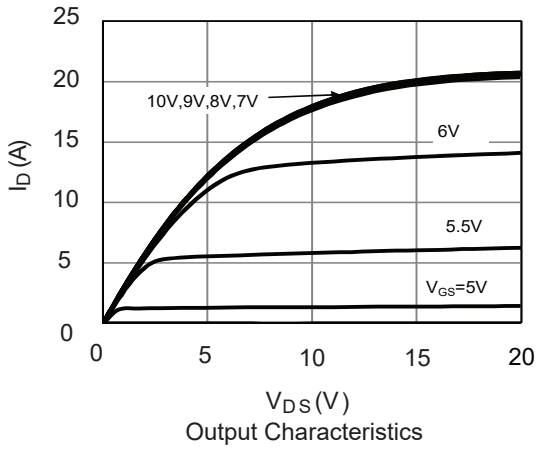

Typical Characteristics

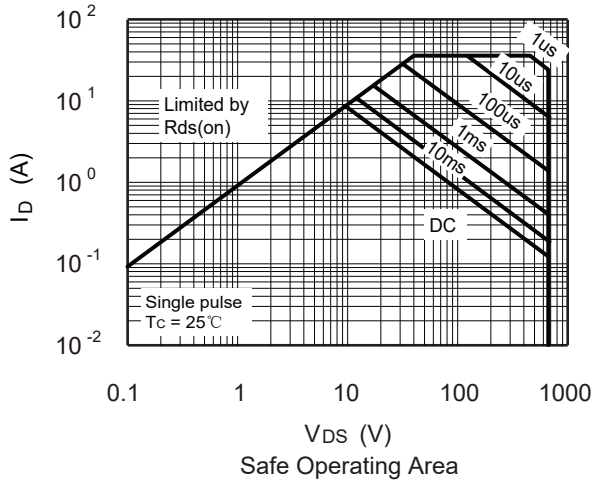

Package Dimension

TO-220

Unit :mm

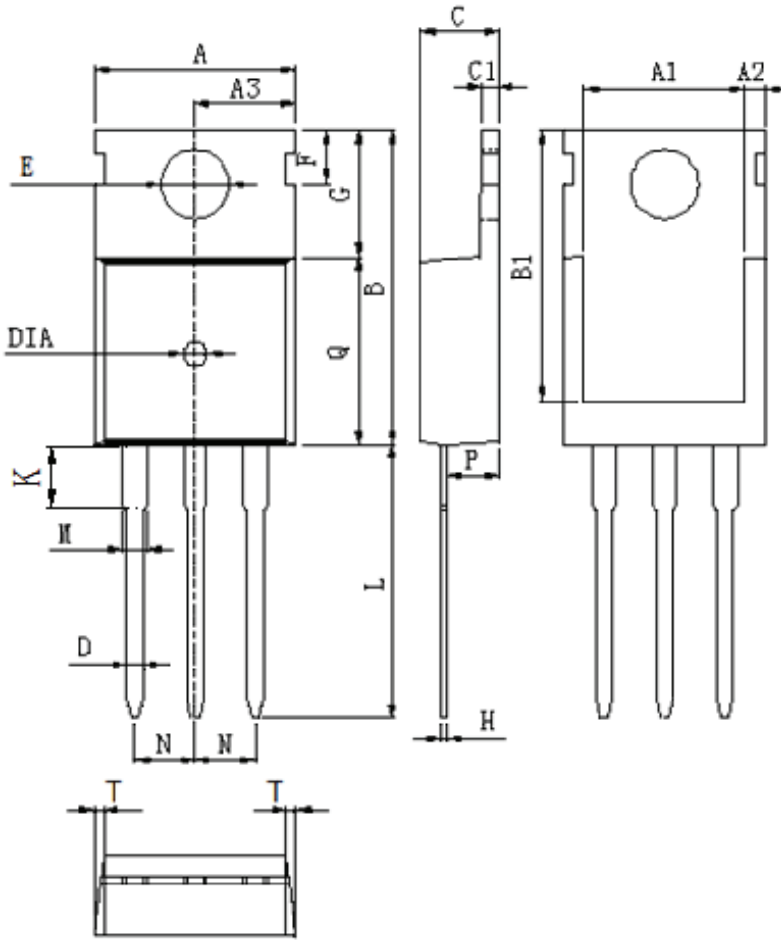

DIM	MILLIMETERS
A	10.0±0.3
A1	8.64±0.2
A2	1.15±0.1
A3	5.0±0.2
B	15.8±0.4
B1	13.2±0.3
C	4.56±0.1
C1	1.3±0.2
D	0.8±0.2
E	3.6±0.2
F	2.95±0.3
G	6.5±0.3
H	0.5±0.1
K	3.1±0.2
L	13.2±0.4
M	1.25±0.1
N	2.54±0.1
P	2.4±0.3
Q	9.0±0.3
T	W:0.35
DIA	⊙1.5 (deep 0.2)

Package Dimension

TO-263

Unit :mm

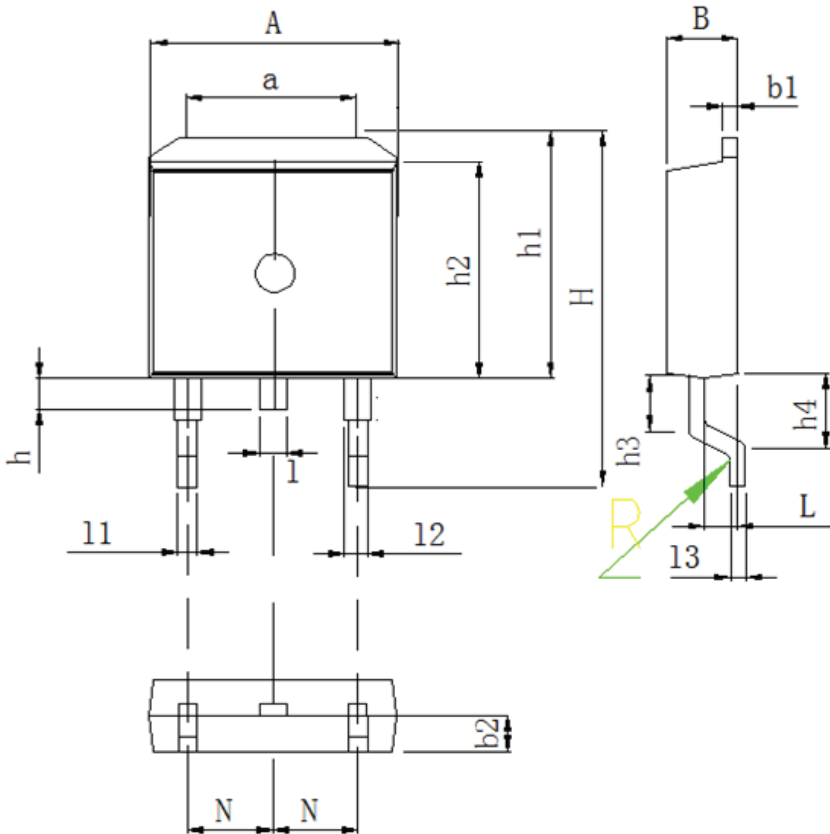

DIM	MILLIMETERS
A	9.8±0.2
a	7.4±0.4
B	4.5±0.2
b1	1.3±0.05
b2	2.4±0.2
H	15.5±0.3
h	1.54±0.2
h1	10.5±0.2
h2	9.2±0.1
h3	1.54±0.2
h4	2.7±0.2
L	2.4±0.2
1	1.3±0.1
11	0.8±0.1
12	1.3±0.1
13	0.5±0.1
N	2.54±0.1
R	0.5R±0.05

Package Dimension

TO-262

Unit :mm

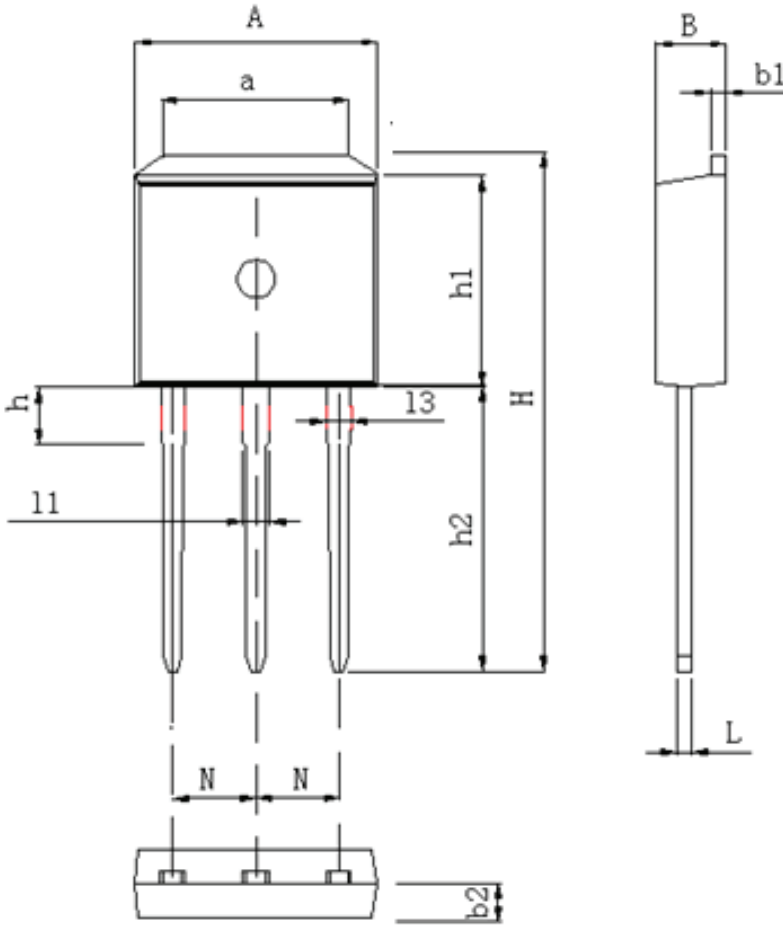

DIM	MILLIMETERS
A	9.98±0.2
a	7.4±0.4
B	4.5±0.2
b1	1.3±0.05
b2	2.4±0.2
H	23.9±0.3
h	3.1±0.2
h1	9.16±0.2
h2	13.2±0.2
L	0.5±0.1
l1	1.3±0.1
l2	0.8±0.1
N	2.45±0.1

Package Dimension

TO-220F

Unit :mm

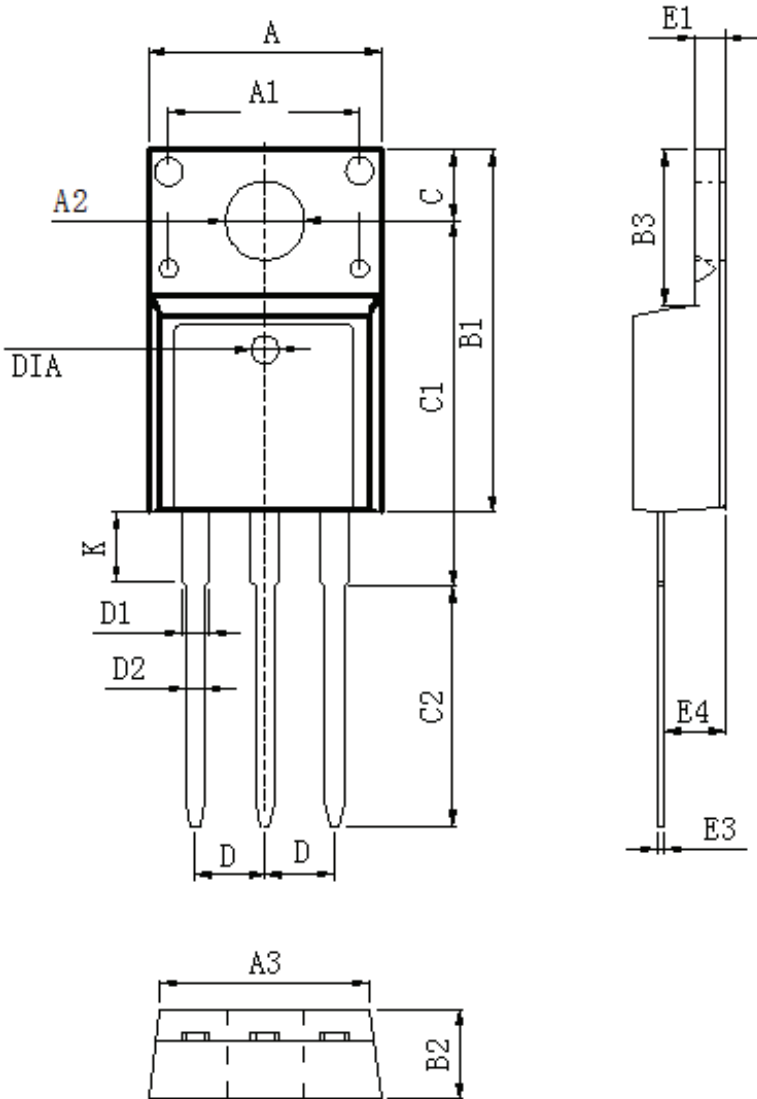

DIM	MILLIMETERS
A	10.16±0.3
A1	7.00±0.1
A2	3.3±0.2
A3	9.5±0.2
B1	15.87±0.3
B2	4.7±0.2
B3	6.68±0.4
C	3.3±0.2
C1	12.57±0.3
C2	10.02±0.5
D	2.54±0.05
D1	1.28±0.2
D2	0.8±0.1
K	3.1±0.3
E1	2.54±0.1
E3	0.5±0.1
E4	2.76±0.2
DIA	⊙1.5 (deep 0.2)