

RECOMMENDED PCB LAYOUT  
TOLERANCE: ±0.05  
TOP VIEW

MATERIALS

1. HOUSING&COVER : LCP BLACK.
2. TERMINAL : C2680 (T=0.20mm)  
PLATING: GOLD PLATED ON CONTACT AREA,  
MATTE TIN PLATED . ON SOLDER TAILS,  
UNDER NICKEL PLATED.
3. SHELL : SUS304 (T=0.30mm)  
PLATING: NICKEL PLATED OVERALL.
4. SPRING SHELL: SUS304-3/4H (T=0.20mm).

SPECIFICATION

1. CURRENT RATING: 0.5A MIN., 3.3V 3A FOR PIN#20(POWER PIN) REFER TO THE ATTACHED MATERIAL SPECIFICATION TEST CONDITIONS,THE PIN#20 CAN MEET 3A TEMPERATURE RISE IS LESS THAN 30°C
2. CONTACT RESISTANCE : 30mΩ MAX.
3. DIELECTRIC WITHSTANDING VOLTAGE :  
500V AC R.M.S. FOR ONE MINUTE.
4. INSULATION RESISTANCE : 100MΩ MIN AT 500V DC.
5. OPERATING TEMPERATURE : -40°C TO +85°C.
6. DURABILITY : 10000 CYCLES.
7. MATING FORCE : 4.5Kgf MAX.
8. UNMATING FORCE : 1.0Kgf~4.0Kgf.



深圳市华宇创精密电子有限公司

|  |                    |                      |   |
|--|--------------------|----------------------|---|
| TOLERANCE:<br>X.X ±0.30<br>X.XX ±0.25<br>X.XXX ±0.15<br>X.' ±2' X.X' ±0.5' | DRAWN BY :<br>陈一鸣  | DATE :<br>2014-02-23 | PART NAME:<br>MINI DP SMT式 带3弹片母座(中心高3.8) |
|  | CHECKED BY:<br>马跃  | DATE :<br>2014-02-23 | PART NO. HYCW31-MDP20-038B                |
| UNIT: mm [inch]<br>SCALE:1:1 SIZE: A4                                      | APPROVED BY:<br>邱敏 | DATE :<br>2014-02-23 | MOLD NO.                                  |
|  |                    |                      | DRAW NO: HYC-2603301440                   |
|  |                    |                      | SHEET NO. 1 OF 1                          |

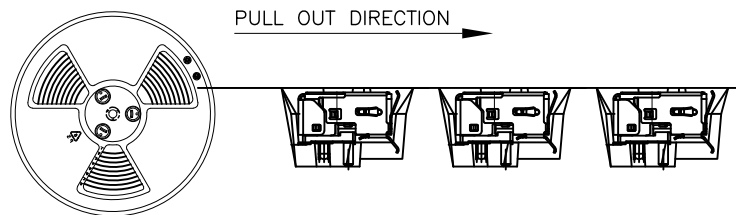
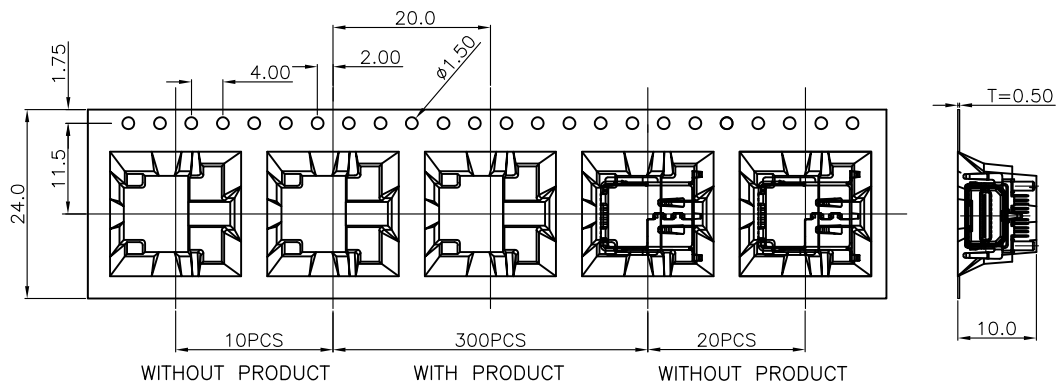

**PACKAGE**

1. SIZE :

REEL : DIA.=330mm  
 CORTON : 350x350x340mm (LxWxH)

2. QUANTITY :

300 PCS/REEL  
 11 REEL/CARTON = 3300PCS

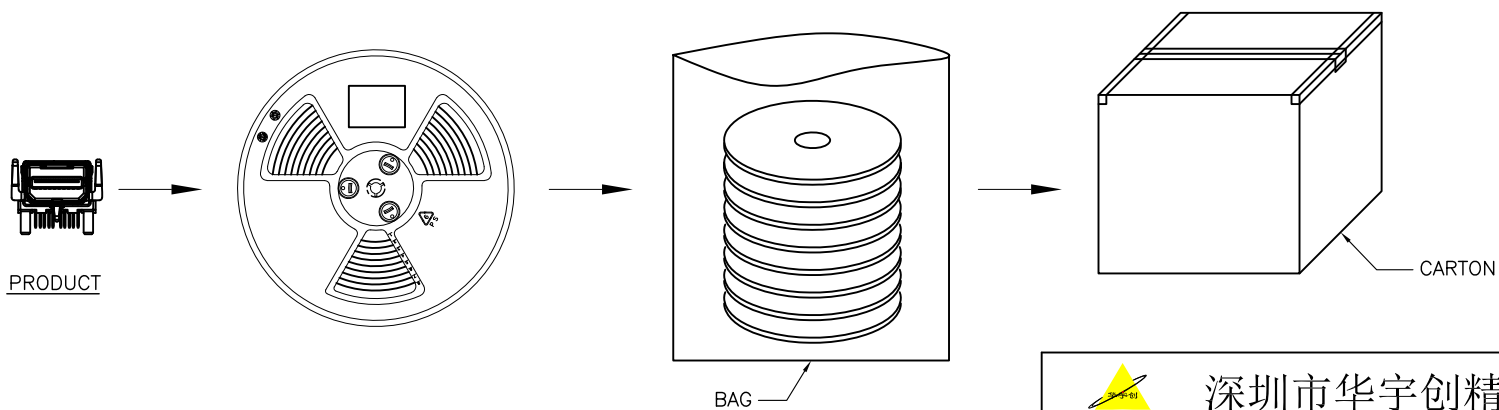

|   |                    |                      |                              |
|---|--------------------|----------------------|------------------------------|
|  <b>深圳市华宇创精密电子有限公司</b> |                    |                      |                              |
| TOLERANCE:<br>X.X ±0.30<br>X.XX ±0.25<br>X.XXX ±0.15<br>X.' ±2' X.X' ±0.5'                                  | DRAWN BY :<br>陈一鸣  | DATE :<br>2014-02-23 | PART NAME:<br>包装图            |
|   | CHECKED BY:<br>马跃  | DATE :<br>2014-02-23 | PART NO.<br>MOLD NO.         |
| UNIT: mm [inch]<br>SCALE:1:1 SIZE: A4   | APPROVED BY:<br>邱敏 | DATE :<br>2014-02-23 | DRAW NO:<br>SHEET NO. 1 OF 1 |