

METAL MASK T=0.08
TOLERANCE:±0.05MM
(FOR REFERENCE ONLY)

NOTES:

1:MATERIAL

1-1: SUS-301 THICKNE=0.15MM

2:SPECIFICATIONS

2-1: RATED CURRENT: 1.0A

2-2: VOLTAGE RATING: 1.5V

2-3: CONTACT RESISTANCE: 80mΩ/MAX

2-4: WELDING THRUST: ≥3KG

2-5: OPERATING TEMPERATURE: -40°C~+85°C

3:SALT SPRAY TIME: 24H

4:ELECTROPLATE: THE NICKEL-PLATED SUBSTRATE IS 50u" Min

5:REQUIREMENTS

5-1:TERMINAL TO EAT FULL TIN,NOTPEELING,
WELDING OBVIOUS COLOR AND OTHED ADVERSE

5-2:ROHS、REACH、HF HALOGER ADVERSE OF DOMESTIC
AND INTERNATIONAL ENVIRONMNTAL REQUIREMENTS



深圳市华宇创精密电子有限公司

| | | | |
|--|--------------------|----------------------|---|
| TOLERANCE: X.X ±0.30 X.XX ±0.25 X.XXX ±0.15 X.' ±2' X.X' ±0.5' | DRAWN BY : 陈一鸣 | DATE : 2014-02-23 | PART NAME: H1.4mm 线夹 |
| | CHECKED BY: 马跃 | DATE : 2014-02-23 | PART NO. HYCW14-08A-140B MOLD NO. |
| UNIT: mm [inch] SCALE:1:1 SIZE: A4 | APPROVED BY: 邱敏 | DATE : 2014-02-23 | DRAW NO: HYC-2604020912 SHEET NO. 1 OF 1 |

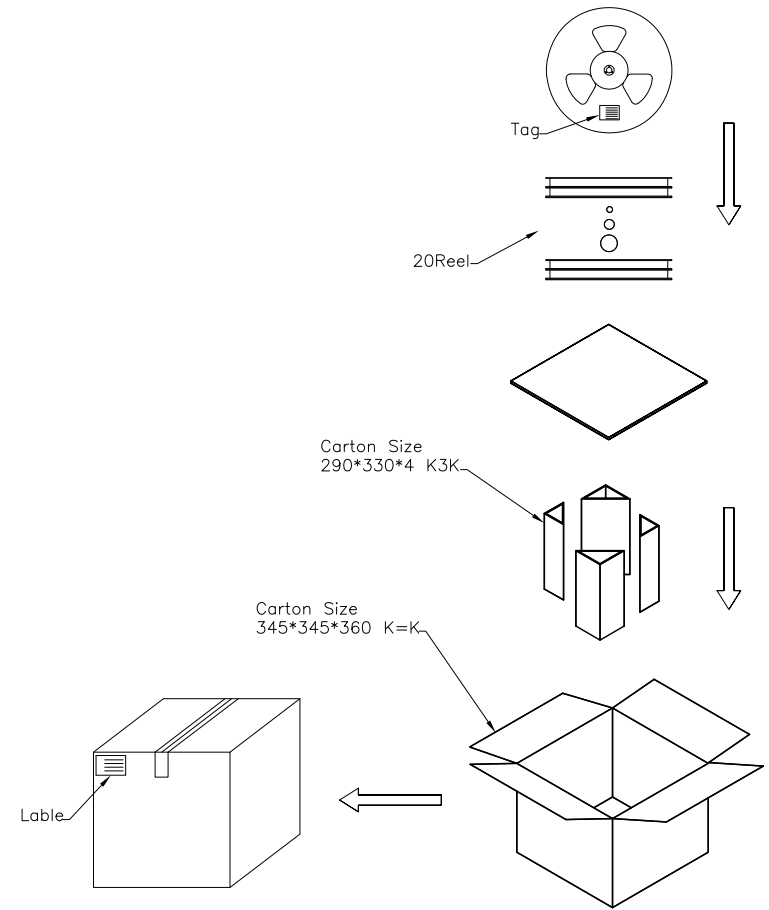
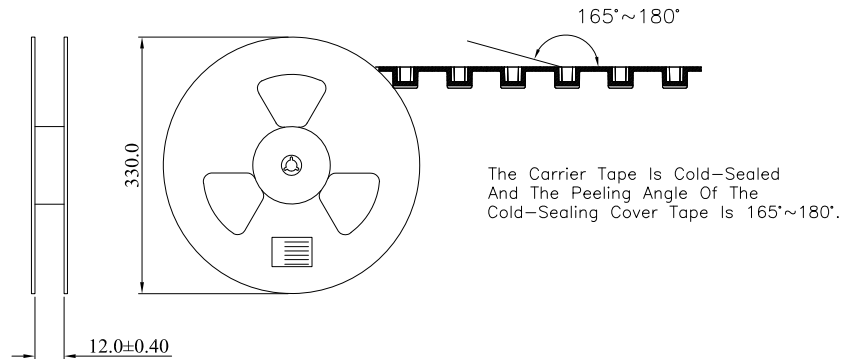
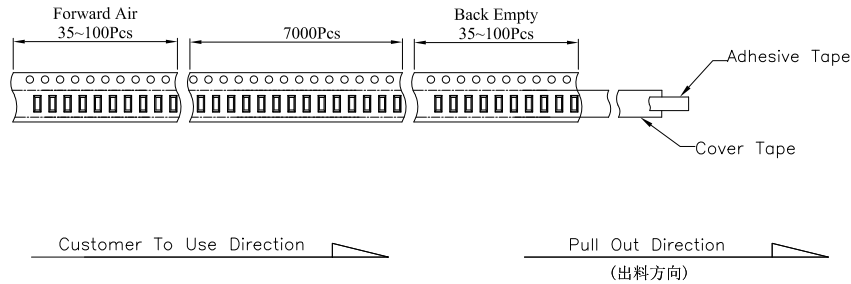
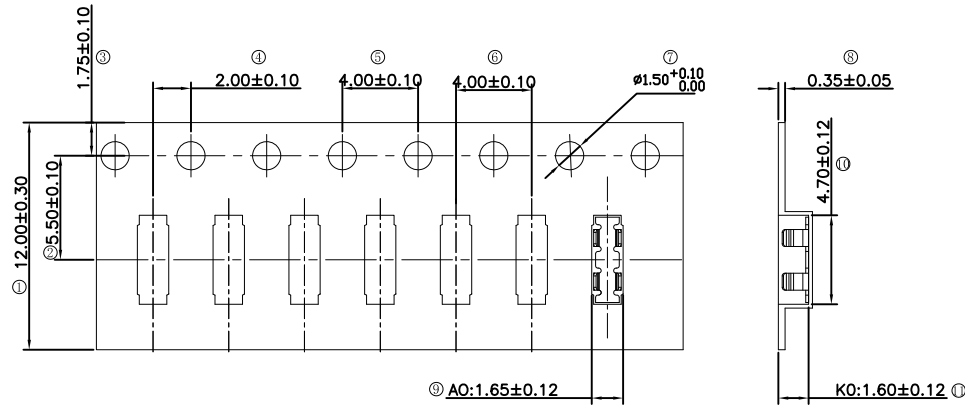

| | | | |
|---|--------------------|----------------------|-------------------|
| | | | |
| <h2>深圳市华宇创精密电子有限公司</h2> | | | |
| TOLERANCE: X.X ± 0.30 X.XX ± 0.25 X.XXX ± 0.15 X.' $\pm 2'$ X.X' $\pm 0.5'$ | DRAWN BY : 陈一鸣 | DATE : 2014-02-23 | PART NAME: 包装图 |
| UNIT: mm [inch] | CHECKED BY: 马跃 | DATE : 2014-02-23 | PART NO. |
| SCALE: 1:1 SIZE: A4 | APPROVED BY: 邱敏 | DATE : 2014-02-23 | DRAW NO. |
| | | | SHEET NO. 1 OF 1 |