

SVC系列

特长/用途

- 4Φ ~ 12.5Φ、105℃、2,000小时寿命保证
- 静电容量值高于RVT系列、缩体小型化
- 适用表面黏着之高密度PCB设计
- 符合RoHS指令

规格表

项目	性能																																
工作温度范围	-55℃~+105℃																																
额定电压范围	6.3V~100V																																
额定静电容量容许误差值	±20% (120Hz, 20℃)																																
标称容量范围	0.1~1500F																																
漏电流(20℃)	I=0.01CV或3(μA/微安)中的任一个较大值以下(2分钟后) I=漏电流(μA/微安)、C=额定静电容量(μF/微法拉)、V=额定直流工作电压(V/伏特)																																
损失角正切值(120Hz, 20℃)	<table border="1"> <thead> <tr> <th>额定电压</th> <th>6.3</th> <th>10</th> <th>16</th> <th>25</th> <th>35</th> <th>50</th> <th>63</th> <th>80</th> <th>100</th> </tr> </thead> <tbody> <tr> <td>损失角正切值(最大值)</td> <td>0.30</td> <td>0.24</td> <td>0.20</td> <td>0.18</td> <td>0.16</td> <td>0.14</td> <td>0.14</td> <td>0.14</td> <td>0.14</td> </tr> </tbody> </table> <p>当额定静电容量大于1,000微法拉时, 每增加1,000微法拉需加0.02.</p>	额定电压	6.3	10	16	25	35	50	63	80	100	损失角正切值(最大值)	0.30	0.24	0.20	0.18	0.16	0.14	0.14	0.14	0.14												
额定电压	6.3	10	16	25	35	50	63	80	100																								
损失角正切值(最大值)	0.30	0.24	0.20	0.18	0.16	0.14	0.14	0.14	0.14																								
温度特性(120Hz)	<p>阻抗比不可大于下表所列数值</p> <table border="1"> <thead> <tr> <th colspan="2">额定电压</th> <th>6.3</th> <th>10</th> <th>16</th> <th>25</th> <th>35</th> <th>50</th> <th>63</th> <th>80</th> <th>100</th> </tr> </thead> <tbody> <tr> <td rowspan="2">阻抗比</td> <td>Z(-25℃)/Z(+20℃)</td> <td>4</td> <td>3</td> <td>2</td> <td>2</td> <td>2</td> <td>2</td> <td>2</td> <td>2</td> <td>2</td> </tr> <tr> <td>Z(-55℃)/Z(+20℃)</td> <td>8</td> <td>5</td> <td>4</td> <td>3</td> <td>3</td> <td>3</td> <td>3</td> <td>3</td> <td>3</td> </tr> </tbody> </table>	额定电压		6.3	10	16	25	35	50	63	80	100	阻抗比	Z(-25℃)/Z(+20℃)	4	3	2	2	2	2	2	2	2	Z(-55℃)/Z(+20℃)	8	5	4	3	3	3	3	3	3
额定电压		6.3	10	16	25	35	50	63	80	100																							
阻抗比	Z(-25℃)/Z(+20℃)	4	3	2	2	2	2	2	2	2																							
	Z(-55℃)/Z(+20℃)	8	5	4	3	3	3	3	3	3																							
耐久性	<table border="1"> <tbody> <tr> <td>保证寿命时间</td> <td>2000小时</td> </tr> <tr> <td>静电容量变化率</td> <td>≤当初始值的±30%</td> </tr> <tr> <td>损失角正切值</td> <td>≤初始规格值的200%</td> </tr> <tr> <td>漏电流</td> <td>≤初始规格值</td> </tr> </tbody> </table> <p>×于105℃环境中供给额定电压2,000小时后, 待制品回复至20℃的环境中进行量测时, 需满足上列要求。</p>	保证寿命时间	2000小时	静电容量变化率	≤当初始值的±30%	损失角正切值	≤初始规格值的200%	漏电流	≤初始规格值																								
保证寿命时间	2000小时																																
静电容量变化率	≤当初始值的±30%																																
损失角正切值	≤初始规格值的200%																																
漏电流	≤初始规格值																																
高温无负荷特性	<table border="1"> <tbody> <tr> <td>保证寿命时间</td> <td>1,000小时</td> </tr> <tr> <td>静电容量变化率</td> <td>≤初始值的±30%</td> </tr> <tr> <td>损失角正切值</td> <td>≤初始规格值的300%</td> </tr> <tr> <td>漏电流</td> <td>≤初始规格值</td> </tr> </tbody> </table> <p>*于105℃环境中不供给额定电压1,000小时后, 待制品回复至20℃的环境中进行量测时, 需满足上列要求。</p>	保证寿命时间	1,000小时	静电容量变化率	≤初始值的±30%	损失角正切值	≤初始规格值的300%	漏电流	≤初始规格值																								
保证寿命时间	1,000小时																																
静电容量变化率	≤初始值的±30%																																
损失角正切值	≤初始规格值的300%																																
漏电流	≤初始规格值																																
耐焊接热	<p>在250℃的条件下, 电容器在热板上保持30秒, 然后从热板上取下电容器, 让其在室温下恢复, 电容器应满足以下要求</p> <table border="1"> <tbody> <tr> <td>容量变化率</td> <td>±10%初始值内</td> </tr> <tr> <td>损耗角正切值</td> <td>≤初始规定值</td> </tr> <tr> <td>漏电流</td> <td>≤初始规定值</td> </tr> </tbody> </table>	容量变化率	±10%初始值内	损耗角正切值	≤初始规定值	漏电流	≤初始规定值																										
容量变化率	±10%初始值内																																
损耗角正切值	≤初始规定值																																
漏电流	≤初始规定值																																
纹波电流与频率修正系数	<table border="1"> <tbody> <tr> <td>频率(Hz)</td> <td>50, 60</td> <td>120</td> <td>1k</td> <td>10k≤</td> </tr> <tr> <td>修正系数</td> <td>0.50</td> <td>0.65</td> <td>0.85</td> <td>1.0</td> </tr> </tbody> </table>	频率(Hz)	50, 60	120	1k	10k≤	修正系数	0.50	0.65	0.85	1.0																						
频率(Hz)	50, 60	120	1k	10k≤																													
修正系数	0.50	0.65	0.85	1.0																													

寸法图

图 1

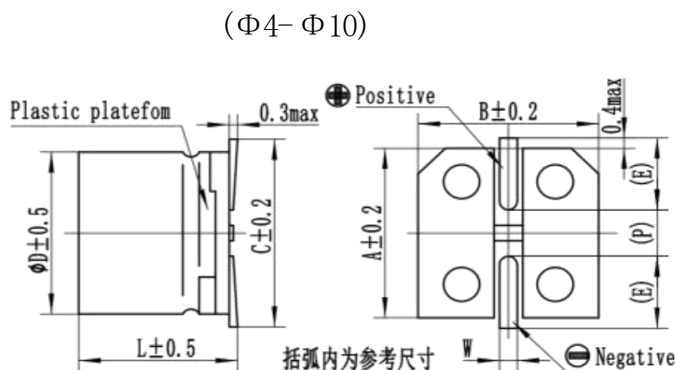

制品各项寸法

单位: 毫米

ΦD	L	A	B	C	W	P±0.2	图号
4	5.4±0.5	4.3	4.3	5.1	0.5~0.8	1.0	1
5	5.4±0.5	5.3	5.3	5.9	0.5~0.8	1.5	1
6.3	5.4±0.5	6.6	6.6	7.2	0.5~0.8	2.0	1
6.3	7.7±0.5	6.6	6.6	7.2	0.5~0.8	2.0	1
8	10.2±0.5	8.3	8.3	9.0	0.7~1.1	3.1	1
10	10.2±0.5	10.3	10.3	11.0	0.7~1.1	4.7	1

(*): Φ4~6.3最大值为 0.4

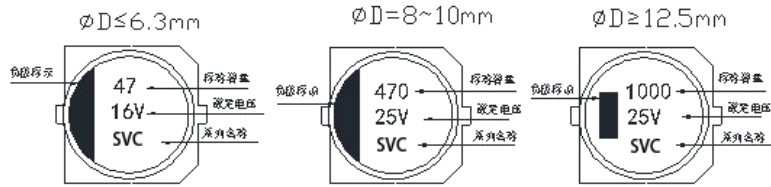

制品尺寸与容许纹波电流一览表

尺寸：直径(ΦD) \times 长度(L)，(毫米/mm)

容许纹波电流：毫安/均方根(mArms)，100k赫兹(Hz)，105 $^{\circ}$ C

阻抗值：欧姆(Ω)/最大值，100k赫兹(Hz)，20 $^{\circ}$ C

额定电压Vac 内容 静电容量 (μF /微法)		6.3V (0J)		10V (1A)		16V (1C)		25V (1E)		35V (1V)		50V (1H)	
		$\Phi D \times L$	mA	$\Phi D \times L$	mA	$\Phi D \times L$	mA	$\Phi D \times L$	mA	$\Phi D \times L$	mA	$\Phi D \times L$	mA
10	100											4 \times 5.4	15
22	220							4 \times 5.4	20	4 \times 5.4	25	5 \times 5.4 6.3 \times 4.5	20 40
33	330							4 \times 5.4	38	5 \times 5.4	28		
47	470					4 \times 5.4	29	5 \times 5.4	43	5 \times 5.4	32	6.3 \times 5.8	28
68	680			4 \times 5.4	42	5 \times 5.4	240	5 \times 5.4	50	6.3 \times 5.8	40		
100	101	4 \times 5.8	69			5 \times 5.4 6.3 \times 4.5	240 64	6.3 \times 5.4	81	6.3 \times 5.8	82	6.3 \times 7.7	113
150	151			5 \times 5.4	58	6.3 \times 5.4	300	6.3 \times 7.7	93	6.3 \times 7.7	90		
220	221	5 \times 5.8 6.3 \times 4.5	50 65	6.3 \times 4.5	65	6.3 \times 5.4	300	6.3 \times 7.7 6.3 \times 5.4	142 123	6.3 \times 7.7	151	8 \times 10.2	145
330	331	6.3 \times 5.8	102	6.3 \times 5.4	82	6.3 \times 7.7	600	6.3 \times 7.7	150	8 \times 10.2	182	10 \times 0.2	170
470	471	6.3 \times 5.8	125	6.3 \times 5.8	95	6.3 \times 7.7	650	8 \times 10.2	251	8 \times 10.2	285		
680	681	6.3 \times 7.7	154	8 \times 10.2	110	8 \times 10.2	850	10 \times 10.2	280	10 \times 10.2	360		
1.000	102			8 \times 10.2	135			10 \times 10.2	320				
1.500	152	8 \times 10.2	200	10 \times 10.2	155	12.5 \times 13.5	285						
2.200	222	10 \times 10.2	220	10 \times 10.2	180								

	63		100	
	$\Phi D \times L$	mA	$\Phi D \times L$	mA
4.7			5 \times 5.4	20
10	5 \times 5.4	25	6.3 \times 5.4	30
	6.3 \times 5.4	30	6.3 \times 7.7	34
22	6.3 \times 7.7	35	8 \times 10.2	43
47	6.3 \times 7.7	40	8 \times 10.2	48
220	10 \times 10.2	280		

产品编码说明

SVC系列 35V 220微法拉 ±20% 8*10

SVC | **1V** | **221** | **M** | **0810**

系列名 | 额定电压 | 额定静电容量 | 容许误差值 | 制品尺寸

额定电压 (W. V)	4	6.3	10	16	20	25	35	50	63	80	100
电压代码	0G	0J	1A	1C	1D	1E	1V	1H	1J	1K	2A
额定电压 (W. V)	160	180	200	250	315	350	400	420	450		
电压代码	2C	2S	2D	2E	2F	2V	2G	2P	2W		

标称容量	1	2.2	3.3	4.7	6.8	8.2	10	22	33	47	100	150
容量代码	1R0	2R2	3R3	4R7	6R8	8R2	100	220	330	470	101	151
容量允许误差	±5%			±10%			±20%			0~20%		
代码	J			K			M			A		
尺寸	4*5.4		5*5.4		6.3*5.4		6.3*7.7		8*6.5		8*10.2	
代码	0405		0505		0605		0607		0806		0810	
标称容量	220	330	470	680	1000	1500	2200					
容量代码	221	331	471	681	102	152	222					
容量允许误差	-10~30%			-10~20%								
代码	Q			V								
尺寸	10*10.2		8*12		10*12							
代码	1010		0812		1012							

贴片型铝电解电容器

SVC

卷筒

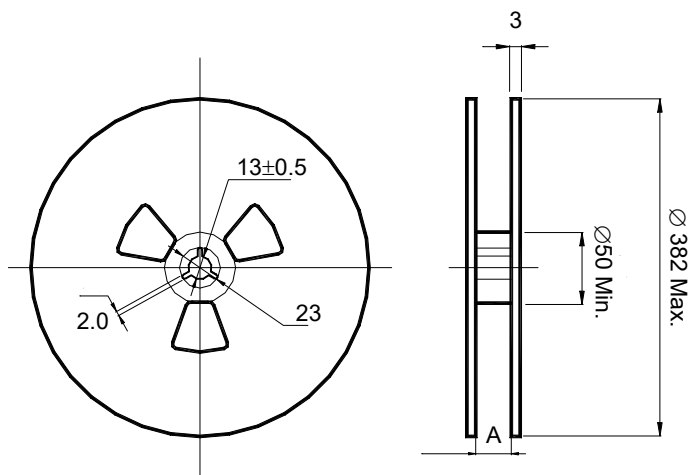

包装数量: Package quantity

规格 Specification	卷装数量 Quantity/Reel	大箱装数量 Quantity/Bag	小箱装数量 Quantity/Bag	A± 0.3 (MM)	D±2 (MM)
Φ4*5.4	2000 pcs	54000pcs	24000pcs	14	382
Φ5*5.4	1000 pcs	27000pcs	12000pcs	14	382
Φ6.3*4.5	1500 pcs	22000pcs	10000pcs	18	382
Φ6.3*5.4	1000 pcs	22000pcs	10000pcs	18	382
Φ6.3*7.7	1000 pcs	16500pcs	7500pcs	18	382
Φ8*10.2	500 pcs	7500pcs	3500pcs	26	382
Φ10*10.2	500 pcs	7500pcs	3500pcs	26	382
Φ12.5*13.5	200 pcs	2400pcs	1000pcs	34	332
Φ16*16.5	125pcs	1125pcs	500pcs	46	332
Φ16*16.5	150 pcs	1350 pcs	600pcs	46	332

贴片型铝电解电容器

无铅回流焊接: Lead-free Reflow Soldering Condition

A. 回流焊条件推荐: Recommended Conditions for Reflow Soldering:

(1) 应采用红外线及热风回流焊接, 不宜采用汽相加热回流焊接;

A thermal condition system such as infrared radiation (IR) or hot blast should be adopted, and vapor heat transfer systems (VPS) are not recommended.

(2) 推荐回流焊只进行一次, 回流焊次数如果需要二次, 必须相隔60分钟以上;

Reflow soldering should be performed one time. If the capacitor has to be reflowed twice, 60 minutes must be layout between each time.

(3) 无铅回流焊, 请符合下述条件:

For lead-free type reflow soldering, please observe proper conditions below:

a) 从150°C至180°C的预热时间 < 120秒以内;

The time of preheating from 150°C to 180°C shall be within maximum 120 seconds;

b) 电容器顶部温度超过217°C的焊接时间不超过tL时间;

The time of soldering temperature at 217°C measured on capacitors' top shall not exceed tL (second);

c) 电容器顶部温度超过230°C的焊接时间不超过td时间;

The time of soldering temperature at 230°C measured on capacitors' top shall not exceed td (second);

d) 电容器顶部尖峰温度不超过Tp°C, 在5°C范围内的实际尖峰温度时间不超过tp时间

The peak temperature on capacitors' top shall not exceed Tp(°C), and the time within 5°C of actual peak temperature shall not exceed tp (second).

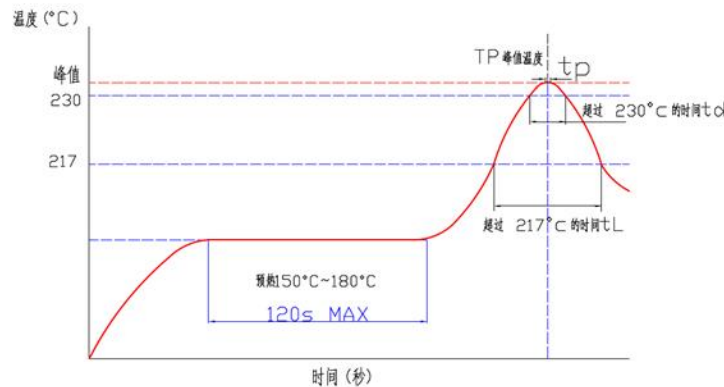

尖峰温度允许范围: Allowable Range of Peak Temperature

Size	Thickness (mm)	Tp (°C)	tL (second)	td (second)
Ø4~Ø6.3*7.7L	≥2.5	250±0	≤60	≤20
Ø8*6.5L	≥2.5	240±0	≤30	≤10
Ø8/10×10.2L	≥2.5	235±0	≤40	≤10

表面安装推荐尺寸: Recommended Land Size (Unit: mm)

尺寸Size	X	Y	a
Φ4	1.6	2.6	1.0
Φ5	1.6	3.0	1.4
Φ6.3	1.6	3.5	1.9
Φ8	2.5	3.5	3.0
Φ10	2.5	4.0	4.0

