

NO.	ECN NO.	DESCRIPTION	DATE

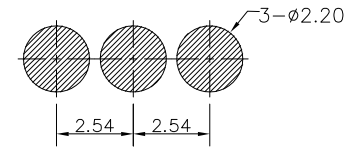

RECOMMENDED PCB LAYOUT

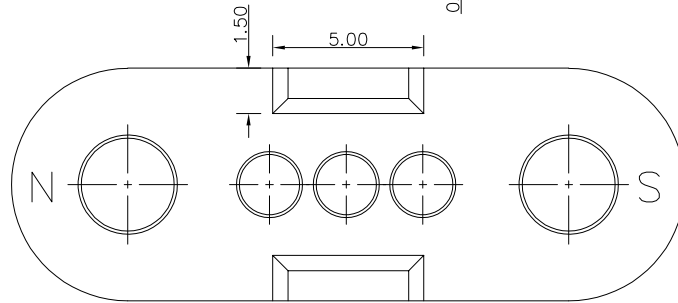
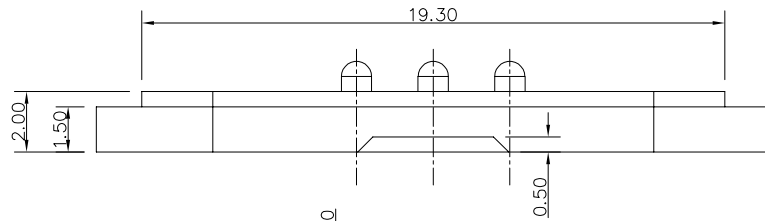
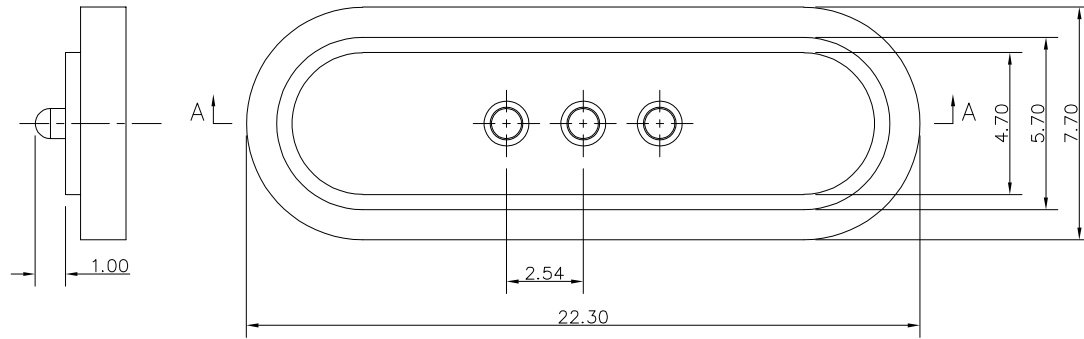
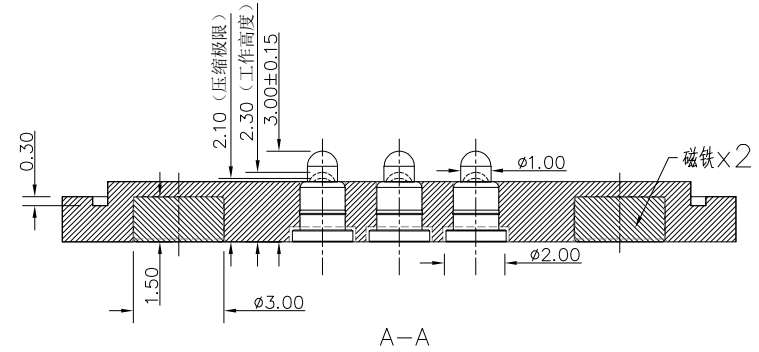

Note:

- Material(材料):
 Housing: PA46+30%GF (胶芯: PA46)
 Barrel: Brass C3604 (针管: 黄铜 C3604)
 Plunger: Brass C3604 (针头: 黄铜 C3604)
 Spring: SUS304 (弹簧: SUS304)
- Plating(电镀):
 Barrel: 3u' Au over 50~80u' Ni(针管: 镀金3u', 镍底50~80u'.)
 Plunger: 3u' Au over 50~80u' Ni(针头: 镀金3u', 镍底50~80u'.)
 Spring: No plated (弹簧: 不电镀)
- Electrical(电气特性):
 Rated Current & Voltage: DC 12V;1A (额定电压&电流: 直流12V,1A)
 Contact Resistance: 50 mohm Max. at working height.
 接触电阻: 最大50毫欧(在工作高度状态下)
 Insulation Resistance: 1,000MΩ minimum. (绝缘电阻: 1,000MΩ以上)
 Dielectric Withstand Voltage: 500VAC/minute. (抗击电压: 500VAC/minute)
- Mechanical(机械性能):
 Force: 20g±5g at working height. (20g±5g 在工作高度)。
 Durability: 10,000 cycles(min) (寿命: 10000次)
- WorkTemperture(工作环境):
 Withstanding Higt Temperature: 280℃
 Operational Temperature: -40℃~ +85℃

深圳市鑫扬泽电子有限公司



TEL:0755-28773277 FAX:0755-28891353

SCALE:	N/A	UNIT	mm
SHEET:	1 of 1	PROJECTION	
DATE:	2022.2.15	VER.	D.0

THE UNMARKED TOLERANCE ARE AS BELOW :			
LENGTH		ANGLE	
X.XX	±0.05mm	X.XX	±0.5°
X.X	±0.10mm	X.X	±1.0°
X.	±0.20mm	X.	±2.0°

DESIGNED BY:	DWG. NO.	YZ00215030R-03025-02
CHECKED BY:	TITLE:	Pogo pin连接器
APPROVED BY:		