

RECOMMEND PCB LAYOUT  
TOLERANCE: ±0.05  
TOP VIEW

**MATERIALS**

1. HOUSING : HI.-TEMP.PLASTIC(UL 94V-0), BLACK.
2. TERMINAL : COPPER ALLOY,  
PLATING : GOLD PLATED ON CONTACT AREA,  
TIN PLATED ON SOLDER TAILS.
3. SHELL : STEEL,T=0.30mm.  
PLATING : NICKEL PLATED OVERALL.
4. EMI SHIELD : STEEL. T=0.15mm

**SPECIFICATION**

1. CURRENT RATING : 0.5 A. MAX.
2. DIELECTRIC WITHSTANDING VOLTAGE :  
500V AC R.M.S. FOR 1 MINUTE.
3. INSULATION RESISTANCE : 100MΩ MIN.AT 500V DC.
4. CONTACT RESISTANCE : 30mΩ MAX.
5. OPERATING TEMPERATURE : -25°C TO +85°C.
6. INSERTION FORCE : 4.5Kgf MAX.
7. WITHDRAWING FORCE : 1Kgf ~ 4Kgf.



深圳市华宇创精密电子有限公司

<b>TOLERANCE:</b> X.X ±0.30 X.XX ±0.25 X.XXX ±0.15 X.' ±2' X.X' ±0.5'	<b>DRAWN BY :</b> 陈一鸣	<b>DATE :</b> 2014-02-23	<b>PART NAME:</b> HDMI2.1 A TYPE 卧式SMT 带卡点 脚长1.1
	<b>CHECKED BY:</b> 马跃	<b>DATE :</b> 2014-02-23	<b>PART NO.</b> HYCW193-HDMI19-110B <b>MOLD NO.</b>
UNIT: mm [inch] SCALE:1:1 SIZE: A4	<b>APPROVED BY:</b> 邱敏	<b>DATE :</b> 2014-02-23	<b>DRAW NO:</b> HYC-2603201107 <b>SHEET NO.</b> 1 OF 1

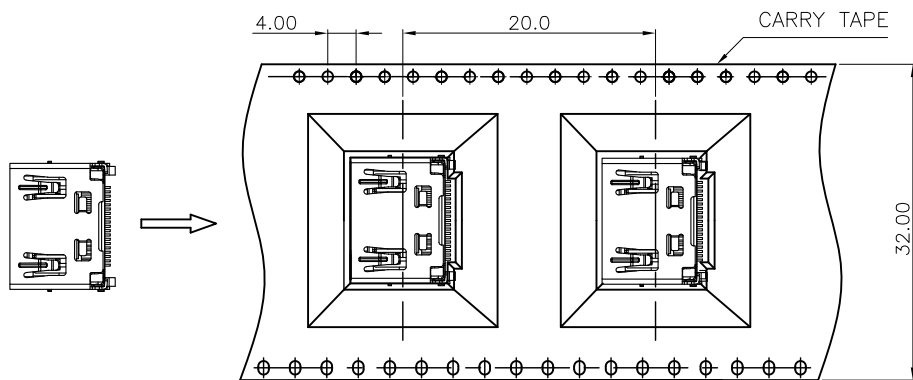
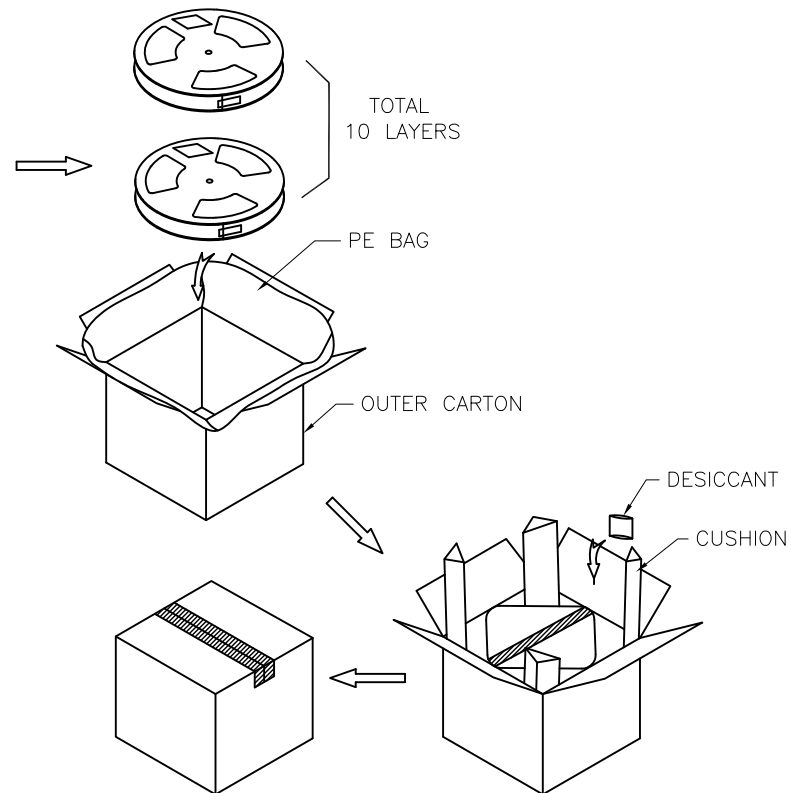
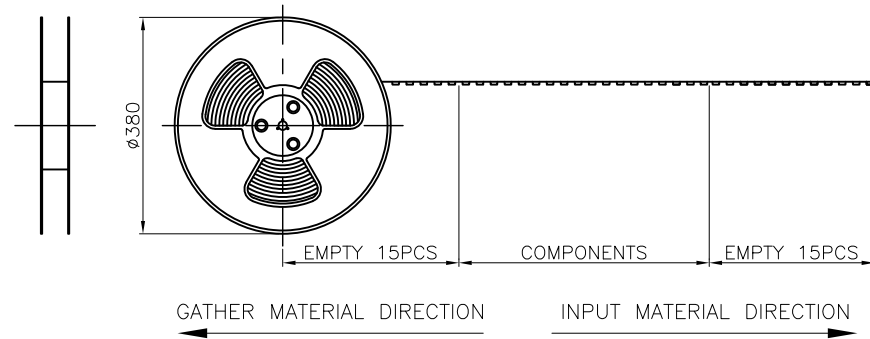

PACKAGE :

1. CORTON SIZE: 400x400x400mm (LxWxH)
2. 500 PCS/REEL
3. 10 REEL/CARTON = 5000PCS



深圳市华宇创精密电子有限公司

TOLERANCE: X.X $\pm 0.30$ X.XX $\pm 0.25$ X.XXX $\pm 0.15$ X.' $\pm 2'$ X.X' $\pm 0.5'$	DRAWN BY : 陈一鸣	DATE : 2014-02-23	PART NAME: 包装图	
	CHECKED BY: 马跃	DATE : 2014-02-23	PART NO.	
UNIT: mm [inch] SCALE:1:1    SIZE: A4	APPROVED BY: 邱敏	DATE : 2014-02-23	DRAW NO:	
			SHEET NO.	1 OF 1