

NO.	ECN NO.	DESCRIPTION	DATE

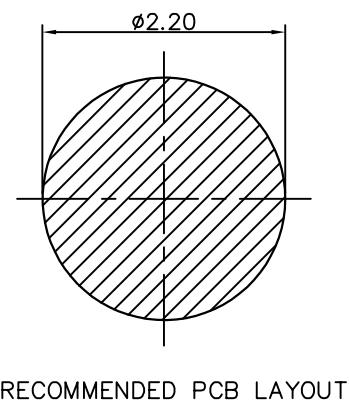
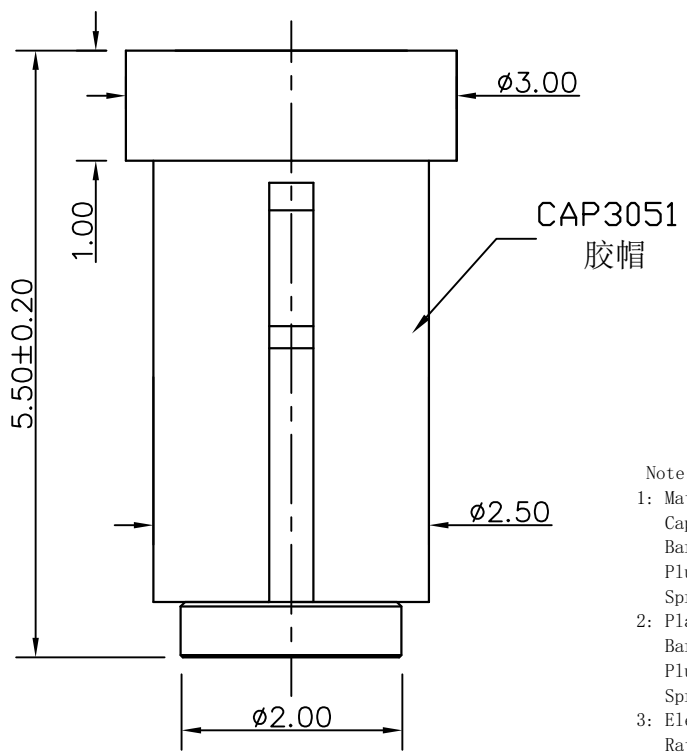
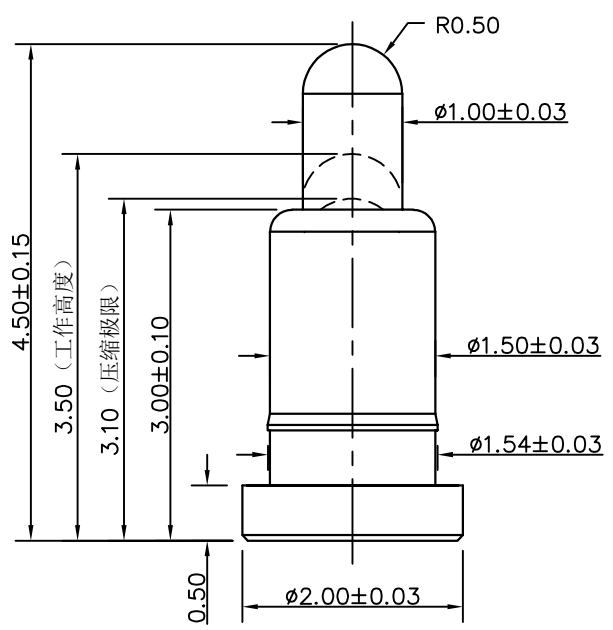

Note:

1: Material(材料):  
 Cap: PA46+30%GF (胶盖: PA46)  
 Barrel: Brass C3604 (针管: 黄铜 C3604)  
 Plunger: Brass C3604 (针头: 黄铜 C3604)  
 Spring: SUS304 (弹簧: SUS304)

2: Plating(电镀):  
 Barrel: 3u' Au over 50~80u' Ni (针管: 镀金3u', 镍底50~80u'.)  
 Plunger: 3u' Au over 50~80u' Ni (针头: 镀金3u', 镍底50~80u'.)  
 Spring: Gold plated (弹簧: 镀金)

3: Electrical(电气特性):  
 Rated Current & Voltage: DC 12V;1A (额定电压&电流: 直流12,1A)  
 Contact Resistance: 50 mohm Max. at working height.  
 接触电阻: 最大50毫欧 (在工作高度状态下)

4: Mechanical(机械性能):  
 Force: 60g±20% at working height. (60g±20% 在工作高度).  
 Full stroke: 1.50mm (全行程: 1.50mm)  
 Durability: 10.000 cycles(min) (寿命: 10000次)

5: WorkTemperture(工作环境):  
 Withstanding Higt Temperature: 280°C  
 Operational Temperature: -20°C ~ +70°C

深圳市鑫扬泽电子有限公司



HTTP://WWW.XYZPOGOPIN.COM

TEL:0755-28773277 FAX:0755-28891353

SCALE:	N/A	UNIT	mm	THE UNMARKED TOLERANCE ARE AS BELOW :		DESIGNED BY:		DWG. NO.	YZ00515045R-02
SHEET:	1 of 1	PROJECTION		LENGTH	ANGLE	CHECKED BY:		TITLE:	成品图
DATE:	2012.10.19	VER.	A.0	X.XX ±0.05mm	X.XX ±0.50°	APPROVED BY:			
				X.X ±0.10mm	X.X ±1.00°				
				X. ±0.20mm	X. ±2.00°				