

DongGuan Chuanghui Electronics Co.,Ltd

东莞市创慧电子有限公司

# 规格书

APPROVING SHEET

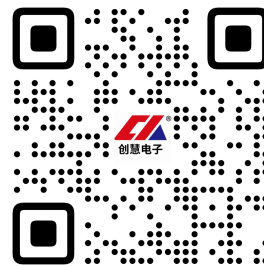

CUSTOMER

客 户: 立创商城

PART NAME : Chip-Aluminum Electrolytic Capacitor

品 名: 片式铝电解电容器

SERIES: \_\_\_\_\_

系 列: VT

SPECIFICATION: \_\_\_\_\_

规格: 50V22  $\mu$ F D6. 3X5. 4L

DATE \_\_\_\_\_

日 期: \_\_\_\_\_

PARTNO \_\_\_\_\_

创慧料号: VT1HM220E054ST

PARTNO \_\_\_\_\_

客户料号: C48543046

制 造		客 户	
MANUFACTURE		CUSTOMER	
拟 制 FORMULATE	批 准 APPROVAL	检 验 CHECK	批 准 APPROVAL
邓瑶玲	刘劲松 技术品质部		

地址: 广东省东莞市谢岗镇金川工业区

电话 (TEL): 0755-83868833

产品规格书 Product Specification

序号 No	目录 INDEX	页 page
1	概述 SCOPE	3
2	外形尺寸图及尺寸表 Case size table	3
3	技术性能 SPECIFICATIONS	4
4	标称电容量、额定电压、额定纹波电流与外形尺寸对应表 Nominal capacitance, rated voltage, rated ripple current and case size table	5-6
5	构造图及材料表 Frame drawing and materials	7
6	试验方法及要求 TESTS	8-11
7	标志 Marking	12
8	片式铝电解电容的编带 V- Chip Type Aluminum Electrolytic Capacitors	12
9	包装数量 Package quantity	13
10	料号编码规则 Material number encoding rules:	14

一、概述 SCOPE

本产品规格书适用于东莞市创慧电子有限公司 VT 型片式铝电解电容器产品。

The product specification is adapted to series VT V-CHIP Aluminum Electrolytic Capacitors of DongGuan chuanghai Electronics CO.,LTD..

二、外形图及尺寸表 Case size table

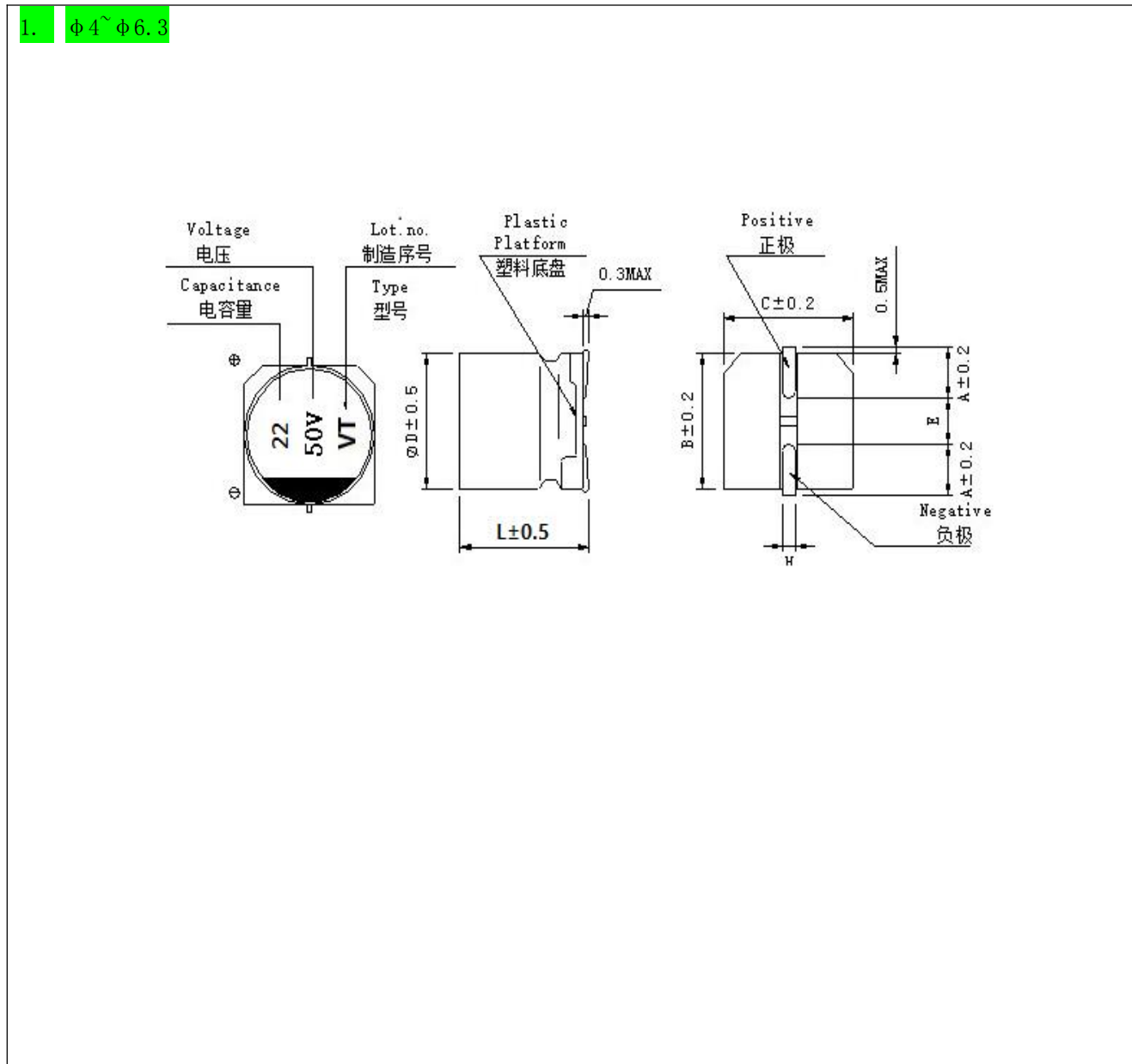

单位:mm

ITEM	4 × 5.4	5 × 5.4	6.3 × 5.4	6.3 × 7.7	6.3 × 10.5	8 × 10.5	8 × 12.5	10 × 10.5	10 × 12.5	12.5 × 13.5	12.5 × 16.5	16 × 16.5	18 × 16.5	18 × 21.5	
A	1.8	2.1	2.4	2.4	2.4	2.9	2.9	3.2	3.2	4.8	4.8	5.8	6.8	6.8	
B	4.3	5.3	6.6	6.6	6.6	8.3	8.3	10.3	10.3	13	13	17	19	19	
C	4.3	5.3	6.6	6.6	6.6	8.3	8.3	10.3	10.3	13	13	17	19	19	
E	1.0	1.3	2.2	2.2	2.2	3.1	3.1	4.5	4.5	4.4	4.4	6.4	6.4	6.4	
L	5.4	5.4	5.4	7.7	10.5	10.5	12.5	10.5	12.5	13.5	16.5	16.5	16.5	21.5	
H	0.5~0.8					0.8 ~ 1.1					1.1~1.4				

三、 技术性能 Specifications

项目 Items	特性 Characteristics										
工作温度范围 Operating Temperature Range	-40°C ~ 105°C										
额定电压范围 Rated Voltage Range	4V ~ 100V										
标称容量范围 Nominal Capacitance Range	0.1 ~ 8200 μF										
标称容量允许偏差 Nominal Capacitance Tolerance	±20% (20°C, 120HZ)										
漏电流 Leakage Current	$I \leq 0.01C_R U_R$ or $3(\mu A)$ , 取较大者 (施加额定电压 2 分钟) $C_R$ : 标称容量 (μF) $U_R$ : 额定电压 (V) $I \leq 0.01C_R U_R$ or $3(\mu A)$ whichever is greater (After 2 minutes' application of rated voltage) $C_R$ : Nominal Capacitance (μF) $U_R$ : Rated voltages (V)										
损耗角正切 (tg δ) Dissipation Factor (Max) 20°C, 120HZ	$U_R$ (V)	4	6.3	10	16	25	35	50	63	80	100
	tg δ	0.35	0.28	0.24	0.20	0.16	0.14	0.12	0.12	0.12	0.12
容量大于 1000uF 者, 每增加 1000uF, 其损耗角正切值增加 0.02 When nominal capacitance exceeds 1000uF, add 0.02 to the value above for each 1000uF increase											

产品规格书 Product Specification

四、标称容量、额定电压、额定纹波电流与外形尺寸对应表

Nominal capacitance, rated voltage, rated ripple current and case size table

V μF	4		6.3		10		16		25		35		50		
	D×L mm	I <sup>~</sup> mA	D×L mm	I <sup>~</sup> mA	D×L mm	I <sup>~</sup> mA	D×L mm	I <sup>~</sup> mA	D×L mm	I <sup>~</sup> mA	D×L mm	I <sup>~</sup> mA	D×L mm	I <sup>~</sup> mA	
0.1													4×5.4	2.3	
0.22													4×5.4	3.4	
0.33													4×5.4	4.1	
0.47													4×5.4	5	
1.0													4×5.4	10	
2.2													4×5.4	16	
3.3												4×5.4	13	4×5.4	16
4.7										4×5.4	22	4×5.4	22	4×5.4	16
													5×5.4	23	
10							4×5.4	28		4×5.4	22	4×5.4	22	5×5.4	25
										5×5.4	28	5×5.4	30	6.3×5.4	32
22			4×5.4	29	4×5.4	28	4×5.4	28	5×5.4	32	5×5.4	45	6.3×5.4	35	
					5×5.4	30	5×5.4	39	6.3×5.4	55	6.3×5.4	60	6.3×7.7	51	
33	4×5.4	31	4×5.4	30	4×5.4	29	5×5.4	35	5×5.4	35	6.3×5.4	60	6.3×7.7	70	
			5×5.4	34	5×5.4	34			6.3×5.4	65					
47	4×5.4	31	4×5.4	32	4×5.4	30	5×5.4	45	5×5.4	35	6.3×5.4	65	6.3×7.7	80	
			5×5.4	46	5×5.4	45	6.3×5.4	70	6.3×5.4	70	6.3×7.7	80			
68	4×5.4	35	5×5.4	46	5×5.4	46	6.3×5.4	70	6.3×5.4	70	6.3×7.7	80	6.3×7.7	80	
100	5×5.4	55	5×5.4	52	5×5.4	50	6.3×5.4	70	6.3×5.4	70	6.3×7.7	90	8×10.5	230	
			6.3×5.4	71	6.3×5.4	69	6.3×7.7	120	6.3×7.7	100	8×10.5	296			
150	6.3×5.4	95	6.3×5.4	90	6.3×5.4	70	6.3×7.7	120	8×10.5	280	8×10.5	300	10×10.5	300	
220	6.3×5.4	100	6.3×5.4	95	6.3×5.4	95	6.3×7.7	120	6.3×7.7	120	8×10.5	320	10×10.5	375	
			6.3×7.7	120	6.3×7.7	120			8×10.5	320	10×10.5	435	10×12.5	385	
330	6.3×7.7	140	6.3×7.7	130	6.3×7.7	130	8×10.5	305	8×10.5	320	10×10.5	450	10×10.5	400	
			8×10.5	290	8×10.5	305			10×10.5	450			12.5×13.5	450	
470	6.3×7.7	150	6.3×7.7	140	6.3×7.7	140	8×10.5	340	8×10.5	330	10×10.5	480	12.5×13.5	490	
			8×10.5	330	8×10.5	340	10×10.5	380	10×10.5	490					
680	8×10.5	340	8×10.5	335	8×10.5	340	10×10.5	450	10×10.5	500	12.5×13.5	600	16×16.5	750	
			10×10.5	380											
820	8×10.5	340	8×10.5	335	10×10.5	380	10×10.5	450	12.5×13.5	520	12.5×16.5	700	16×16.5	850	
1000	8×10.5	350	8×10.5	340	8×10.5	350	10×10.5	550	12.5×13.5	550	16×16.5	800	18×16.5	990	
			10×10.5	410											
1500	10×10.5	500	10×10.5	475	12.5×13.5	600	12.5×13.5	650	12.5×16.5	650	16×16.5	900			
2200			12.5×13.5	680	12.5×13.5	680	16×16.5	900	16×16.5	900	18×16.5	1050			
3300			12.5×16.5	850	16×16.5	950	16×16.5	950	18×16.5	1150					
4700			16×16.5	1000	16×16.5	1000	18×16.5	1225	18×21.5	1300					
6800			18×16.5	1290	18×16.5	1290									
8200			18×21.5	1450	18×21.5	1450									

I<sup>~</sup>=Rated ripple current (mA) (105°C, 120HZ) I<sup>~</sup>=额定纹波电流 (mA) (105°C, 120HZ)

产品规格书 Product Specification

Nominal capacitance, rated voltage, rated ripple current and case size table

V μF	63		80		100	
	D×L mm	I <sub>r</sub> mA	D×L mm	I <sub>r</sub> mA	D×L mm	I <sub>r</sub> mA
0.1	4×5.4	1.0				
0.22	4×5.4	2.3				
0.33	4×5.4	3.5				
0.47	4×5.4	5.0				
1.0	4×5.4	8			4×5.4	10
2.2	4×5.4	12			4×5.4	15
					5×5.4	32
					6.3*5.4	35
3.3	4×5.4	20			5×5.4	35
4.7	5×5.4	25			5×5.4	40
					6.3×5.4	45
10	6.3×5.4	42			6.3×5.4	50
					6.3×7.7	60
					6.3×7.7	65
22	6.3×7.7	50	8×10.5	100	8×10.5	80
					8×10.5	90
33	8×10.5	90	8×10.5	100	10×10.5	110
					8×10.5	100
47	8×10.5	100	10×10.5	150	10×10.5	130
68	8×10.5	115				
100	10×10.5	150	10×10.5	180	12.5×13.5	220
150	10×10.5	170	12.5×13.5		16×16.5	240
220	10×10.5	205	16×16.5	410	16×16.5	410
	12.5×13.5	250				
330	12.5×16.5	300	16×16.5	510	18×16.5	520
470	16×16.5	450	18×16.5	560		
680	18×16.5	600				
1000	18×21.5	800				

I<sub>r</sub>=Rated ripple current (mA) (105°C, 120HZ) I<sub>r</sub>=额定纹波电流 (mA) (105°C, 120HZ)

■ 额定纹波电流的频率系数

Frequency coefficient of ripple current

Frequency 频率	50Hz	120Hz	300Hz	1KHZ	10K-100KHz
Coefficient 系数	0.70	1.00	1.17	1.36	1.50

五、构造图及材料表 Frame drawing and materials

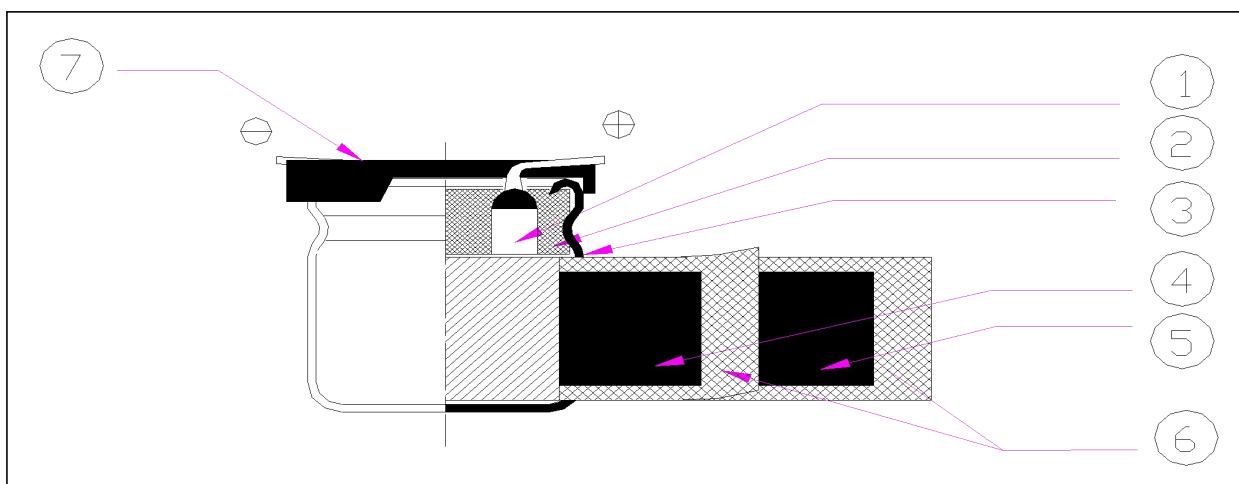

序号 No.	部件名称 Parts	材料名称 Material	主要供应厂家名称 Main supply Factory
1	引出线	铝线 LG3+镀锡铜钢线 AL- wire LG3+Tin- plating of copper cover steel	南通全用电子工业有限公司 NANTONG GENENIC ELECTRONIC INDUSTRY CO., LTD
2	橡胶塞	丁基橡胶 IIR rubber	天台鹏宇橡胶有限公司 Tiantai Pengyu Rubber Co., Ltd 浙江天台祥和实业股份有限公司 Zhejiang Tiantai Xianghe Industrial Co., Ltd
3	PE 铝壳 PE- CASE	99.5%纯度铝 AL - 99.5%	深圳市协升精密制品有限公司 Shenzhen Xiesheng Precision Products Co., Ltd 杭州临安亿鹏电子科技有限公司 Hangzhou Lin'an Yipeng Electronic Technology Co., Ltd
4	阳极箔 AL - foil(+)	99.99%或 99.98%形成铝箔 Formed AL 99.99% or 99.98%	东阳光化成箔有限公司 Dongguang Sunshine Foil Co., Ltd. 立敦电子科技有限公司 Lidon Electronic Technology Co., Ltd.
5	阴极箔 AL - foil(-)	99.7%铝箔 Etched AL 99.7%	博罗冠业电子有限公司 AFT ELECTRONIC CO. LTD. BOLUO
6	电解纸 Separstor paper	电解电容器纸 Electrolytic Capacitor paper	浙江凯恩特种纸业有限公司 Zhejiang Kane Special Paper CO.,Ltd. 山东鲁南新材料股份有限公司 ShandongLunanNew MaterialCo.,Ltd
7	座板 BASE	PPA	鸿信德电子科技有限公司 Hongxinde Electronic Technology Co.Ltd.

六、试验方法及要求 Tests

1	系列号(SERIES)	VT 系列(VT SERIES)										
2	额定电压 (rated voltage)	4~100V										
3	工作温度范围 Operating temperature range operating	工作温度范围是指电容器在额定电压下能持续工作的所允许外部环境的温度范围 operating temperature range is the range of ambient temperature at which the capacitor can be operated continuously at rated voltage SPEC:-40~+105°C										
4	电容容量 capacitance	测量等效电路图 measuring circuit equivalent series circuit										
		测量温度 20°C	measuring temperature									
		测量频率 120HZ	measuring frequency									
		测量电压 0.5Vrms	measuring voltage									
	标称电容容量允许偏差:±20% MAX	Nominal Capacitance Tolerance:±20% MAX										
5	损耗角正切 tangent of the loss angle	损耗角正切的测量应要和测量电容容量一样的条件下进行 Measurement should be made under the same conditions as those given for the measurement of capacitance SPEC:										
	损耗角正切 (tg δ)	U <sub>r</sub> (V)	4	6.3	10	16	25	35	50	63	80	100
		tg δ	0.35	0.28	0.24	0.20	0.16	0.14	0.12	0.12	0.12	0.12
6	漏电流 leakage current	将额定电压加在电容和 1000±100Ω 的保护电阻上。在充电 2 分钟后, 按下列等式计算漏电流 the rated voltage shall be applied across the capacitor and its protective resistor which shall be 1000±100Ω. The leakage current shall be then measured after an electrifications period of (A)min. The leakage current shall be calculated by the following equation 在加上额定电压一定时间后, 应满足下列要求: I≤0.01CV or 3 μA Which is greater(取较大者)(20°C, 2 分钟) SPEC: The following specifications shall be satisfied when the rated voltage is applied for the required time.										
7	允许最大纹波电流 Maximum permissible ripple current	在规定的某一频率下的最大交流电流, 在该电流下电容器连续工作。即使在测过第 16 项下的耐久性后, 此要求仍要满足。在此, DC 电压加上最大纹波电压小于等于额定电压。 The maximum sinusoidal alternating current of a frequency specified below, at which the capacitor can be operated continuously. This requirement shall be satisfied even after the measurement of clause 16(electrical endurance) Where(DC voltage +peak ripple voltage)≤rated voltage										

接上表

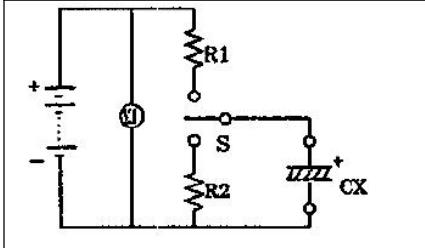
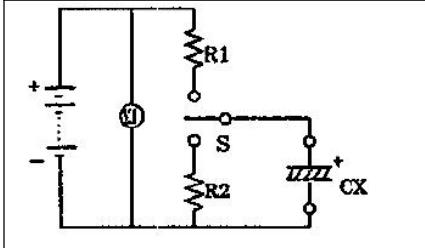
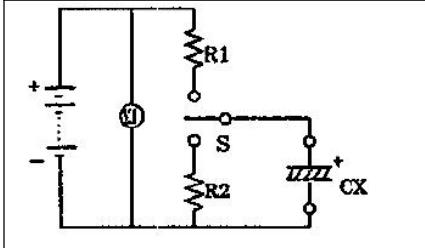
8	温度特性 Characteristics of temperature	<table border="1"> <thead> <tr> <th>步骤 step</th> <th>温度 temperature</th> <th>持续时间 Duration</th> </tr> </thead> <tbody> <tr> <td>1</td> <td>20±2℃</td> <td>15 分钟 15 min</td> </tr> <tr> <td>2</td> <td>最低工作温度 minimum operating temperature</td> <td>2 小时 2 hours</td> </tr> <tr> <td>3</td> <td>20±2℃</td> <td>15 分钟 15 min</td> </tr> <tr> <td>4</td> <td>最高工作温度 maximum operating temperature</td> <td>2 小时 2 hours</td> </tr> </tbody> </table> <p>步骤 1: 测量容量, 损耗角正切和阻抗 Step1: Capacitance, tangent of the loss angle impedance shall be measured.</p> <p>步骤 2: 在电容器存放 2 小时后, 测量容量, 损耗角正切和阻抗 Step2: After the capacitor being stored for 2hours, Capacitance, tangent of the loss angle and impedance shall be measured.</p> <p>步骤 3: 电容器在 20±2℃下存放 15 分钟 Step3: The capacitor being stored fro 15min at20±2℃</p> <p>步骤 4: 在电容器存放 2 小时后, 测量容量和漏电流。 Step4: After the capacitor being stored for 2hours, capacitance and leakage current shall be measured</p> <table border="1"> <thead> <tr> <th>额定电压 rated voltage</th> <th>4</th> <th>6.3</th> <th>10</th> <th>16</th> <th>25</th> <th>35</th> <th>50</th> <th>63</th> <th>80</th> <th>100</th> </tr> </thead> <tbody> <tr> <td>Z(-25℃/Z(+20℃))</td> <td>7</td> <td>4</td> <td>3</td> <td>2</td> <td>2</td> <td>2</td> <td>2</td> <td>2</td> <td>2</td> <td>2</td> </tr> <tr> <td>Z(-40℃/Z(+20℃))</td> <td>15</td> <td>8</td> <td>6</td> <td>4</td> <td>4</td> <td>3</td> <td>3</td> <td>3</td> <td>3</td> <td>3</td> </tr> </tbody> </table>	步骤 step	温度 temperature	持续时间 Duration	1	20±2℃	15 分钟 15 min	2	最低工作温度 minimum operating temperature	2 小时 2 hours	3	20±2℃	15 分钟 15 min	4	最高工作温度 maximum operating temperature	2 小时 2 hours	额定电压 rated voltage	4	6.3	10	16	25	35	50	63	80	100	Z(-25℃/Z(+20℃))	7	4	3	2	2	2	2	2	2	2	Z(-40℃/Z(+20℃))	15	8	6	4	4	3	3	3	3	3
		步骤 step	温度 temperature	持续时间 Duration																																														
		1	20±2℃	15 分钟 15 min																																														
		2	最低工作温度 minimum operating temperature	2 小时 2 hours																																														
		3	20±2℃	15 分钟 15 min																																														
4	最高工作温度 maximum operating temperature	2 小时 2 hours																																																
额定电压 rated voltage	4	6.3	10	16	25	35	50	63	80	100																																								
Z(-25℃/Z(+20℃))	7	4	3	2	2	2	2	2	2	2																																								
Z(-40℃/Z(+20℃))	15	8	6	4	4	3	3	3	3	3																																								
9	浪涌测试 Surge test	<p>在规定温度下, 循环测试 1000 次, 每次充电 30±5 秒, 在放电大约 5 分 30 秒。在标准温度条件下存放使其稳定, 然后测试。</p> <p>The capacitor shall be subjected to 1000cycles at a temperature specified below, each consisting of a charge period of 30±5sec, followed by a discharge period of approx. 5min30sec. And the capacitor shall be stored under standard conditions thermal to obtain stability,after which measurements shall be made.</p> <p>measurement circuit(测试电路图)</p> <table border="1"> <tr> <td rowspan="4">  </td> <td>VS:浪涌电压 Surge voltage</td> <td>V1:直流电压 DC voltmeter</td> </tr> <tr> <td>R1:保护电阻 (1KΩ) Protective series resistor</td> <td>R2:放电电阻器 Discharge resistor</td> </tr> <tr> <td>CX:测试电容 Test capacitor</td> <td>S:开关 Switch</td> </tr> <tr> <td colspan="2"></td> </tr> </table> <p>SPEC: 1) <math>\Delta C/C \leq 15\%</math> 2) <math>\text{tg } \delta &lt; \text{规定值}</math> 3) 电压</p> <table border="1"> <thead> <tr> <th>RATED VOLTAGE (V<sub>DC</sub>)</th> <th>4</th> <th>6.3</th> <th>10</th> <th>16</th> <th>25</th> <th>35</th> <th>50</th> <th>63</th> <th>80</th> <th>100</th> </tr> </thead> <tbody> <tr> <td>SURGE VOLTAGE (V<sub>DC</sub>)</td> <td>5</td> <td>8</td> <td>13</td> <td>20</td> <td>32</td> <td>44</td> <td>63</td> <td>72</td> <td>92</td> <td>115</td> </tr> </tbody> </table>		VS:浪涌电压 Surge voltage	V1:直流电压 DC voltmeter	R1:保护电阻 (1KΩ) Protective series resistor	R2:放电电阻器 Discharge resistor	CX:测试电容 Test capacitor	S:开关 Switch			RATED VOLTAGE (V <sub>DC</sub> )	4	6.3	10	16	25	35	50	63	80	100	SURGE VOLTAGE (V <sub>DC</sub> )	5	8	13	20	32	44	63	72	92	115																	
				VS:浪涌电压 Surge voltage	V1:直流电压 DC voltmeter																																													
				R1:保护电阻 (1KΩ) Protective series resistor	R2:放电电阻器 Discharge resistor																																													
				CX:测试电容 Test capacitor	S:开关 Switch																																													
RATED VOLTAGE (V <sub>DC</sub> )	4	6.3	10	16	25	35	50	63	80	100																																								
SURGE VOLTAGE (V <sub>DC</sub> )	5	8	13	20	32	44	63	72	92	115																																								

接上表

10	端子强度 Terminal strength	<p>1) 拉力(tensile)</p> <table border="1" data-bbox="464 333 1449 510"> <thead> <tr> <th>d(mm)</th> <th>[N]</th> <th>Duration time</th> </tr> </thead> <tbody> <tr> <td>0.3&lt;d≤0.5</td> <td>5</td> <td rowspan="3">10±2sec(秒)</td> </tr> <tr> <td>0.5&lt;d≤0.8</td> <td>10</td> </tr> <tr> <td>0.8&lt;d≤1.25</td> <td>20</td> </tr> </tbody> </table> <p>2) 抗弯强度 (Bending) 端子应该在每一方向上折弯一次，总共两次 The terminal shall be subjected to 1 bend in each direction to give a total 2 bends.</p> <table border="1" data-bbox="464 674 1449 848"> <thead> <tr> <th>d(mm)</th> <th>[N]</th> </tr> </thead> <tbody> <tr> <td>0.3&lt;d≤0.5</td> <td>2.5 (0.25KG)</td> </tr> <tr> <td>0.5&lt;d≤0.8</td> <td>5.0 (0.51KG)</td> </tr> <tr> <td>0.8&lt;d≤1.25</td> <td>10.0(1.0KG)</td> </tr> </tbody> </table> <p>端子没有破损或松动 SPEC: No breaking and loosening of terminal</p>	d(mm)	[N]	Duration time	0.3<d≤0.5	5	10±2sec(秒)	0.5<d≤0.8	10	0.8<d≤1.25	20	d(mm)	[N]	0.3<d≤0.5	2.5 (0.25KG)	0.5<d≤0.8	5.0 (0.51KG)	0.8<d≤1.25	10.0(1.0KG)
d(mm)	[N]	Duration time																		
0.3<d≤0.5	5	10±2sec(秒)																		
0.5<d≤0.8	10																			
0.8<d≤1.25	20																			
d(mm)	[N]																			
0.3<d≤0.5	2.5 (0.25KG)																			
0.5<d≤0.8	5.0 (0.51KG)																			
0.8<d≤1.25	10.0(1.0KG)																			
11	可焊性 solderability	<p>焊料(Solder) : H60A. H60S or(或)H63A 焊接温度(Solder temperature) : 245±2℃ 浸入时间(Immersion time) : 3±0.5sec(秒) 浸入深度(Immersion depth) : 2mm 熔化: 松香在酒精的浓度是 25% Flux: 25% by weight of rosin in ethanol 从含浸处到顶部，至少要有 3/4 的部分覆盖有新焊料 SPEC:1)3/4 of the circumference of the surface up to the immersed shall be covered with new solder.</p>																		
12	耐焊接热 Resistance to soldering heat	<p>焊料(Solder) : H60A. H60S or(或)H63A 焊槽温度(Solder temperature) : 260±5℃(or 或 350±10℃ 浸入时间(Immersion time) : 10±1sec(秒) (or 或 3.5±0.5sec) 绝热屏蔽板的厚度 (Thickness of heat shunt:1.6mm) : 1.6mm SPEC:1) <b>电容量变化</b> Change in capacitance: ±10%初始值以内 Within±10% of the initial value 2) <b>损耗角正切</b> tangent of the loss angle: 小于等于初始规定值 The initial specified value or less 3) <b>漏电流</b> leakage current: 小于等于初始规定值 The initial specified value or less</p>																		
13	抗振性 Vibration	<p>试验电容器的耐振性。在整个频率范围内，从 10 赫兹到 55 赫兹，然后再返回到 10 赫兹，就这样在一分钟内往返循环。振幅为 1.5mm。在三个垂直方向上，每一方向要持续 2 小时，总共 6 小时 Only endurance conditioning by sweeping shall be made. The entire frequency range, from 10 to 55VT and return to 10VT, shall be transversed in 1min. Amplitude(total excursion)1.5mm, This motion shall be applied for a period of 2hours in each of 3 mutually perpendicular directions(a total of 6 hours) SPEC:1) <b>电容量的变化</b>(change in capacitance): ±5%初始值以内 (within ±5%of the initial value) 2) <b>无可见损伤</b>(No visible damage)</p>																		

产品规格书 Product Specification

接上表

14	<p>稳态湿热 Damp heat</p>	<p>电容器要在温度 <math>40\pm 2^{\circ}\text{C}</math>，相对湿度 90%到 95%条件下存放 <math>500\pm 8</math> 个小时。然后在标准条件下放 1 到 2 小时后进行测量。</p> <p>the capacitor shall be stored at a temperature of <math>40\pm 2^{\circ}\text{C}</math> and relative humidity of 90 to 95% for <math>500\pm 8</math> hours. And then the capacitor shall be subjected to standard atmospheric conditions for 1 to 2 hours, after which measurements shall be made</p> <p>SPEC:1) <b>电容量的变化</b> change in capacitance: <math>\pm 15\%</math>初始值以内 within <math>\pm 15\%</math> of the initial value;</p> <p>2) <b>损耗角正切</b> tangent of loss angle: 小于等于初始规定值 The initial specified value or less;</p> <p>3) <b>漏电流</b> leakage current: 小于等于初始规定值 The initial specified value or less</p>
15	<p>高温储存 shelf life</p>	<p>在 <math>105^{\circ}\text{C}</math> 温度下不外加电压贮存，电容器存放 1000 小时。然后在标准条件下放 1 到 2 小时后进行测量，并且在测漏电流前，必须满足下列条件。The capacitor shall be stored at <math>105^{\circ}\text{C}</math> temperature specified below for 1000 hours. During which time no voltage shall be applied. And then the capacitor shall be subjected to standard atmospheric conditions for 1 to 2 hours, after which measurements shall be made, Prior to the measurement of leakage current, following conditioning may be made.</p> <p>SPEC:1) <b>电容量的变化</b> change in capacitance: <math>\pm 20\%</math>初始值以内 within <math>\pm 20\%</math> of the initial value; (<math>\leq 16\text{V}</math>: <math>\pm 25\%</math>初始值以内) (<math>\leq 16\text{V}</math>: within <math>\pm 25\%</math> of the initial value);</p> <p>2) <b>损耗角正切</b> tangent of loss angle: <math>\pm 200\%</math>初始规定值以内 within <math>\pm 200\%</math> of the initial value;</p> <p>3) <b>漏电流</b> leakage current: 小于等于初始规定值 The initial specified value or less</p>
16	<p>耐久性 load life</p>	<p>在 <math>105\pm 2^{\circ}\text{C}</math> 下，电容器加额定电压 1000 小时。在标准条件下放 1 到 2 小时后进行测量。</p> <p>The rated voltage shall be applied continuously to the capacitor at maximum operating temperature <math>105\pm 2^{\circ}\text{C}</math> for 1000 hours. And then the capacitor shall be subjected to standard atmospheric conditions for 1 to 2 hours, after which measurement shall be made.</p> <p>SPEC:1) <b>电容量的变化</b> change in capacitance: <math>\pm 20\%</math>初始值以内 within <math>\pm 20\%</math> of the initial value; (<math>\leq 16\text{V}</math>: <math>\pm 25\%</math>初始值以内) (<math>\leq 16\text{V}</math>: within <math>\pm 25\%</math> of the initial value);</p> <p>2) <b>损耗角正切</b> tangent of loss angle: <math>\pm 200\%</math>初始规定值以内 within <math>\pm 200\%</math> of the initial value;</p> <p>3) <b>漏电流</b> leakage current: 小于等于初始规定值 The initial specified value or less</p>

七、标志 Marking (见外形图及尺寸表)

说明：标识中的“VT”是东莞市创慧电子有限公司VT型贴片产品的专属标识。

Information: The mark of “VT” is the special mark of VT for SMD Type of DongGuan chuanguhui Electronics CO.,LTD

八、片式铝电解电容的编带

V- Chip Type Aluminum Electrolytic Capacitors

编带 Carrier tape

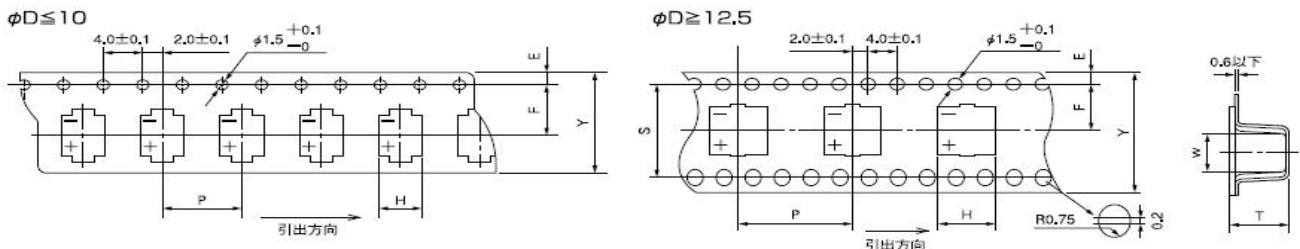

$\phi D \times L$	4×5.4	5×5.4	6.3×5.4	6.3×7.7	6.3*10.5	8×10.5	8×12.5	10×10.5	10×12.5	12.5×13.5	12.5×16.5	16×16.5	18×16.5	18×21.5	(mm)
W	12.0	12.0	16.0	16.0	16.0	24.0	24.0	24.0	24.0	32.0	32.0	44.0	44.0	44.0	
P	8.0	12.0	12.0	12.0	12.0	16.0	16.0	16.0	16.0	24.0	24.0	28.0	32.0	32.0	
F	5.5	5.5	7.5	7.5	7.5	11.5	11.5	11.5	11.5	14.2	14.2	20.2	20.2	20.2	
A <sub>0</sub>	5.0	6.0	7.0	7.0	7.0	8.7	8.7	10.7	10.7	13.2	13.2	17.5	19.5	19.5	
B <sub>0</sub>	5.0	6.0	7.0	7.0	7.0	8.7	8.7	10.7	10.7	13.2	13.2	17.5	19.5	19.5	
T <sub>2</sub>	5.8	5.8	5.8	8.0	11.0	11.0	13.3	11.0	13.3	14.3	17.3	17.3	17.8	22.5	

■ 编带包装盘 Reel

(mm)

$\phi D$	4	5	6.3 (8*6.2)	8	10	12.5	16	18
T	14	14	18	26	26	34	46	46

■ Package quantity 包装数量

$\Phi D \times L$	Quantity / Reel 数量 / 每盘	pcs/ Small packing box 数量/小包装箱	pcs/Large packing box 数量/大包装箱
4×5.4	2000pcs	24000pcs	48000pcs
5×5.4	1000pcs	12000pcs	24000pcs
6.3×5.4、6.3×7.7、8×6.2	1000pcs	10000pcs	20000pcs
8×10.5、10×10.5	500pcs	3500pcs	7000pcs
6.3×10.5	800pcs	8000pcs	16000pcs
8×12.5	400pcs	2800pcs	5600pcs
10×12.5	400pcs	2800pcs	5600pcs
12.5×13.5	200pcs	1200pcs	2400pcs
12.5×16.5	150pcs	900pcs	1800pcs
16×16.5	125pcs	625pcs	1250pcs
18×16.5	125pcs	625pcs	1250pcs
18×21.5	75pcs	375pcs	750pcs



10. 料号编码规则 Material number encoding rules :

<b>VT</b>	<b>1H</b>	<b>M</b>	<b>220</b>	<b>E054</b>	<b>S</b>	<b>T</b>
①系列Series	②电压Voltage	③容差Capacitance Tolerance	④容量Capacitance	⑤尺寸Size	⑥成型Finishing	⑦胶管Sleeve

①系列 Series	CD110	CD288H	CD288L	CD26G	CD26M	CD26L	CD110L	NP	LL	VT	LHD
	CD288S	CD26K	CD26C	CD293	CD294	CD296	CD133	CD134	CD136	VD	

②电压V	4	6.3	10	16	25	35	50	63	80	100	120	140	160	180	200	250	315	350	400	420	450	500	550
代号Code	OC	OJ	1A	1C	1E	1V	1H	1J	1K	2A	2B	2S	2C	2Z	2D	2E	2F	2V	2G	2J	2W	2H	2L

③容差代码code	J	K	M	W	T	Q	P
容差C. T.	±5%	±10%	±20%	-0%~+20%	-10%~+20%	-20%~+30%	-15%~+20%

④容量Cap.	0.1	0.22	0.33	0.47	1	2.2	3.3	4.7	6.8	10	22	33	47	68	100	220	330	3300	...
编码Code	R10	R22	R33	R47	1R0	2R2	3R3	4R7	6R8	100	220	330	470	680	101	221	331	332	...

<b>⑤尺寸</b>																							
直径D	4	5	6.3	8	10	12.5	13	16	18	20	22	25	30	35									
编码Code	C	D	E	F	G	H	K	L	M	N	O	P	Q	R									
高度H	5	5.4	6.2	7	7.7	10.5	11	12	12.5	13	13.5	16	16.5	17	18	20	21	21.5	27	25	30	35	45
编码Code	05	054	062	07	077	105	11	12	125	13	135	16	165	17	18	20	21	215	27	25	30	35	45

⑥成型 Finishing	散装 Bulk	编带 Taping P=2.5	编带 Taping P=5.0	剪脚 Cut Lead L=3.5	K脚 剪脚 L=4.5	S脚 剪脚L=4.5	卧式 H01=4.0	卧式 H02=4.0	贴片 SMD
编码Code	0	TP25	TP5	C35	K45	S45	H140	H240	S

⑦胶管Sleeve	PVC	PET
编码Code	C	T

VT 型产品承认书

参数 项目	电压: 50V	容量: 22uF	容量误差: ±20%	温度范围: -40℃~+105℃						
外型尺寸	直径 D: <u>6.3 mm</u> 高度 L: <u>5.4±0.5mm</u>									
性能	电容量 C: <u>17.6~26.4</u> (uF)    损失 (tgδ) : <u>12</u> %(Max)    漏电 (I) : <u>11</u> uA (Max)									
贮存试验	(105℃ 1000 小时试验后)		容量变化率: ±20%初始值以内 损失值 ≤ 200%初始规定值 漏电流 ≤ 初始规定值							
寿命试验	(105℃ 1000 小时试验后)		容量变化率: ±20%初始值以内 损失值 ≤ 200%初始规定值 漏电流 ≤ 初始规定值							
初始测试(25±3℃)										
No.	1	2	3	4	5	6	7	8	9	10
C	20.7	20.6	20.6	20.6	20.4	20.7	20.7	20.9	20.5	20.6
tgδ (%)	3.83	3.57	3.94	3.71	3.81	3.69	3.77	3.89	3.92	3.84
LC (uA)	1.1	1.3	1.2	1.1	1.0	0.9	1.2	1.0	1.1	1.3
制样: 邓瑶玲					审核: 石彬					批准: 刘劲松
结 论:  1. <input type="checkbox"/> 承 认 2. <input type="checkbox"/> 有条件承认 3. <input type="checkbox"/> 退 料						客户承认章:  客户签发_____ <div style="text-align: right; margin-top: 20px;">                     年 月 日                 </div>				