

产品规格书

PRODUCT SPECIFICATION

产品名称:	扣式超级电容器
Product Name:	Coin-type Supercapacitor
产品型号:	_____
Product Model:	WTC5V50F47Z-0513H
制 定:	_____
Prepared by:	耿梦梵
审 核:	_____
Checked by:	任倩倩
批 准:	_____
Approved by:	张晓丽
发布日期:	_____
Release date	2021-09-24

客户确认栏 / CUSTOMER APPROVAL:

客户确认 / Customer Confirmation:

客户签章 / APPROVAL SIGNET:

日 期 / DATE:

变更履历表
Modified List

版本 Revision	修订人 Approved by	变更内容 Modified content	变更日期 Effective date
WT24.01.01	任倩倩	版式变更	20241001

目 录 / List

质量声明 / Quality Statement.....	4
1. 适用范围 / Scope	5
2. 标准测试条件 / Standard Testing Condition.....	5
3. 一般特性 / General Characteristics	5
4. 环境性能指标 / Environmental Characteristics	6
5. 尺寸及外形 / Product Dimensions	6
6. 命名规则 / Part Number system	7
7. 测试方法 / The Measurement Methods.....	7
8. 注意事项与使用指导 / Handling Precautions and Guidelines.....	8
9. 免责声明 / Products Disclaimer	13

质量声明 / Quality Statement

正确的使用和维护保养才能确保您的电容(或电容系统)长期可靠稳定地运行。

Proper use and maintenance will ensure the supercapacitor operated reliably and consistently for long periods of time.

● 收到产品后, 请检查包装是否完好, 若包装破损, 可能导致产品损坏。若有损坏, 请于五个工作日内联系我司售后或销售人员。

After receiving the product, please check if the packaging is in good condition. If the packing is broken, it may cause damage to the product. If there is any damage, please contact our after-sales or sales staff within five working days.

● 凡不按本说明书规定进行使用或维护保养者, 视同放弃保修权利, 上海闻亭实业有限公司及其服务站有权不再予以保修, 对由此而产生的一切损失也不予以赔偿, 但可以根据情况提供相应的有偿服务。

Anyone who does not use or maintain the supercapacitor according to the manual shall be deemed to give up the warranty right. Shanghai WTSCAP Co,Ltd. and its service station have the right to no longer guarantee the warranty, and will not compensate for any losses arising from it. However, the corresponding paid service can be provided according to the situation.

● 贵司在收到产品及产品说明书后, 请于 7 日内回复。7 日内未回复, 我司将视客户承认此产品及产品说明书符合贵司要求。

Please reply and confirm us within seven working days after receiving your product and specification. We will regard that you agree with the product and the specification meets your requirements if you do not reply within seven working days.

公司总部

地址: 上海市黄浦区广西北路 528 号 1405 室

电话: +86-021-64202890

邮编: 200001

邮箱: service@wtscap.com

服务热线: +86-18818018996

Headquarter

Add: Room 1405, No. 528 Guangxi North Road, Huangpu District, Shanghai, China

Tel: +86-021-64202890

Postcode: 200001

Email: service@wtscap.com

Service Hotline: +86-18818018996

1. 适用范围 / Scope

本产品规格书描述了上海闻亭实业有限公司（以下简称闻亭实业）生产的超级电容器的产品性能指标。

This product specification describes the characteristics of supercapacitor produced by Shanghai WTSCAP Co.,Ltd

2. 标准测试条件 / Standard Testing Condition

一般情况下，在标准大气压下，温度 15~35℃，相对湿度在 25%~75%条件下进行测试，测试前样品在测试温度下放置 12 h 以上，本规格书的测试条件为标准大气压，温度为 25±2℃，相对湿度为 60±15%。

All test and measurements shall be made under standard atmospheric conditions (Temperature: 15~35°C, Relative humidity: 25%~75%) for testing. Before the measurements are made, the supercapacitor shall be store at the measuring temperature for a time sufficient to allow the entire supercapacitor to reach this temperature. All tests of the specification book were carried out under the following environmental conditions:

Temperature: 25±2 °C Humidity:(60±15)%RH Air pressure: standard atmospheric pressure

3. 一般特性 / General Characteristics

测试项目 / Item		规格/条件 / Specification	
1	型号 / Model	WTC5V50F47Z-0513H	
2	标称容量 / Rated discharge capacitance	0.47F	
3	容量偏差 / Capacitance tolerance	-20% ~+80%	
4	额定电压 / Rated voltage	5.5V	
5	浪涌电压 / Surge voltage	5.8 V	
6	标称内阻 Nominal impedance	交流阻抗 / AC Imp @1kHz	≤50Ω
		直流阻抗 / DC Imp	≤75Ω
7	最大峰值电流 / Maximum peak current (1 s)	35m A	
8	漏电流 / Leakage current (72 h)	≤0.005mA	
9	工作温度 / Working temperature range	-40 ~ +70°C	
10	储存温度 / Storage temperature range	-40 ~ +85°C	
11	循环寿命 / Cycle life	25 °C，额定电压到半额定电压间循环充放电 50 万次， ΔC/C ≤30%，ESR≤3 倍规定值(25 °C) 25°C, rated voltage-half rated voltage>500000 cycles, ΔC/C ≤30%, ESR≤ 3 times of specified ESR	

4. 环境性能指标 / Environmental Characteristics

项目 / Item	规格/条件 / Specification/Condition
1 温度特性 / Temperature characteristics	+70°C 时 $\Delta C/C$ $\leq 30\%$, ESR \leq 规定值 (25 °C) $\Delta C/C$ $\leq 30\%$, ESR \leq specified ESR(25°C) at +70°C -40 °C 时 $\Delta C/C$ $\leq 30\%$, ESR ≤ 3 倍规定值 (25 °C) $\Delta C/C$ $\leq 30\%$, ESR ≤ 3 times of specified ESR(25 °C) at -40°C
2 高温负荷特性 / High temperature load	+70°C 加额定电压, 1000h 后, $\Delta C/C$ $\leq 30\%$, ESR ≤ 3 倍规定值。 $\Delta C/C$ $\leq 30\%$, ESR ≤ 3 times of specified ESR(25°C) at +70°C/1000hrs/rated voltage
3 高温存储 / High temperature storage	+70°C, 放置 1000h 后, $\Delta C/C$ $\leq 30\%$, ESR ≤ 3 倍规定值。 $\Delta C/C$ $\leq 30\%$, ESR ≤ 3 times of specified ESR(25°C) at +70°C/1000hrs/standby after fully charge
4 湿热特性 / Hygrothermal characteristics	+40 \pm 2°C, 90--95%RH, 240h, $\Delta C/C$ $\leq 30\%$, ESR ≤ 3 倍规定值。 +40 \pm 2°C, 90--95%RH, 240h, $\Delta C/C$ $\leq 30\%$, ESR ≤ 3 times of specified ESR(25°C)

5. 尺寸及外形 / Product Dimensions

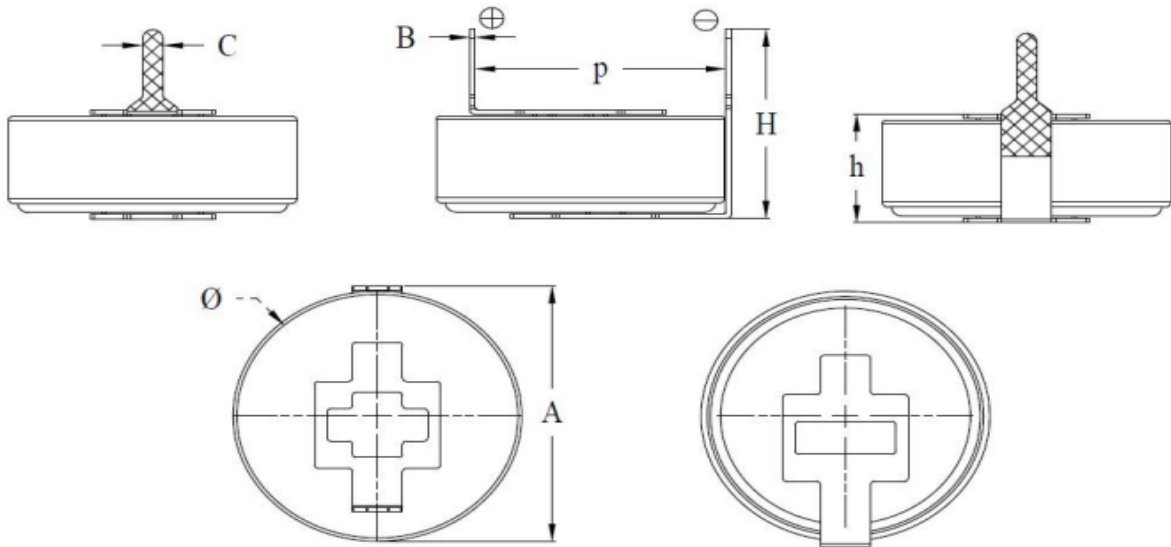

项目	标准	项目	标准
Φ	11.5 \pm 0.5 mm	H	8.6 \pm 0.5 mm
h	4.5 \pm 0.5 mm	p	10.0 \pm 0.5 mm
A	12.0 \pm 0.5 mm	B	0.20 \pm 0.05 mm
C	0.8 \pm 0.1 mm		

6. 命名规则 / Part Number system

WTR Series		3V0 Voltage		10F0 Capacitance		Z Tolerance		1025 Size		L Pin		Y Colour(selectable)	
代码/Code	系列/Series	代码/Code	电压/Voltage	代码/Code	容量/Capacitance	代码/Code	容量偏差/Tolerance	代码/Code	尺寸/Size	代码/Code	引脚/Pin	代码/Code	颜色/Colour
WTR	圆柱形/Cylindrical	2V7	2.7V	0F1	0.1F	Z	-20% ~ +80%	0510	5mm*10mm	V	V型/Type-V	BL	蓝色/Blue
WTC	纽扣型/Coin type	3V0	3.0V	1F5	1.5F	Q	-10% ~ +30%	0512	5mm*12mm	H	H型/Type-H	BK	黑色/Black
WTM	组合型/Module	3V6	3.6V	15F0	15F	K	-10% ~ +10%	0813	8mm*13mm	C	C型/Type-C	Y	黄色/Yellow
		5V5	5.5V	380F0	380F	M	-20% ~ +20%	1025	10mm*25mm	T	T型/Type-T	G	绿色/Green
		6V0	6.0V	600F0	600F	N	0 ~ +40%	0820	8mm*20mm	L	寻针/Guide pin type	R	红色/Red
		7V5	7.5V					3560	35mm*60mm	S	牛角/Horn pose	W	白色/White
		15V0	15.0V					3570	35mm*70mm	B	焊片/Solder lug type		
										M	螺栓/Bolt type		
										W	导线/Wire type		

7. 测试方法 / The Measurement Methods

7.1 容量测量（恒流放电法） / Capacitance（Constant current discharge method）

测试步骤 / Test Steps:

- 将转换开关 S 切换到恒流/恒压源，以恒定电流给待测电容器恒流充电；
Turn the switch S to the DC power supply, charge the supercapacitor with constant current to rated voltage(U_R);
- 在待测电容器的电压达到额定电压 U_R 后恒压充电 30 min；
Constant voltage charge at rated voltage(U_R) for 30min;
- 在恒压充电 30 min 后，将转换开关 S 切换到恒流放电装置以恒定电流恒流放电，放电截止到 0.1V；
Discharge the supercapacitor with constant current to 0.1V.

充放电曲线图 / Curve for charge-discharge

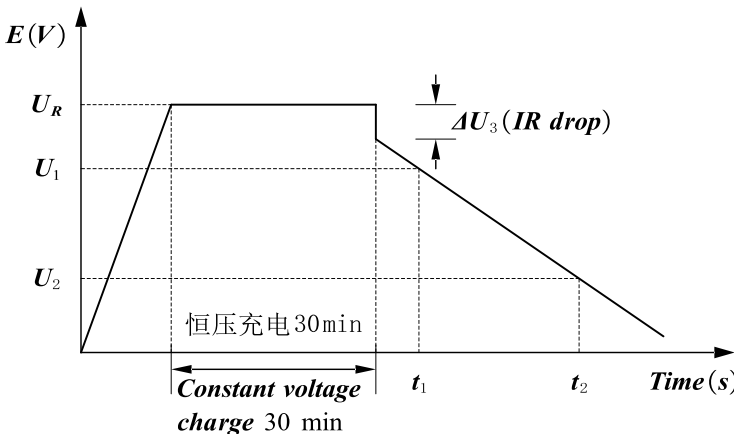

计算方法 / Computing method

$$C = \frac{I (t_2 - t_1)}{U_1 - U_2}$$

C: 容量 / The capacitance (F)

I: 放电电流 / The discharge current (A)

t_1 : 放电开始到电压达到 U_1 的时间 /

The time from discharge start to reach U_1 (s);

t_2 : 放电开始到电压达到 U_2 的时间 (s) /

The time from discharge start to reach U_2

U_1 : 80% U_R (V);

U_2 : 40% U_R (V)

7.2 内阻测量 / AC resistance method

内阻 / Resistance	计算方法 / Computing method
交流内阻 AC resistance	<p>交流阻抗通过交流内阻测试仪测量，测量电压的频率为 1 kHz。 Measure AC internal resistance by the LCR meter (Frequency: 1kHz).</p> $R_{AC} = \frac{U}{I}$ <p>R_{AC}: 交流电阻 / <i>The AC internal resistance</i> (Ω) U: 交流电压有效值 (<i>V r.m.s</i>) <i>The effective value of AC voltage</i> (<i>V r.m.s</i>) I: 交流电流有效值 (<i>A r.m.s</i>) <i>The effective value of AC current</i> (<i>A r.m.s</i>)</p>

7.3 漏电流测量 / Leakage current

测试步骤 / Test Steps:

- 测试漏电流前待测超级电容器应充分放电，一般放电 1 h 以上；
Before this measurement is made, the capacitors shall be fully discharge. Discharge procedure shall take more than 1h;
- 在电容器两端加额定电压 U_R ；
Apply rated voltage to the supercapacitor;
- 待超级电容器电压达到额定电压 U_R 后，测量串联保护电阻两端电压 U_V 。
After the voltage of the supercapacitor reaches the rated voltage U_R , the voltage U_V at both ends of the series protection resistor is measured.

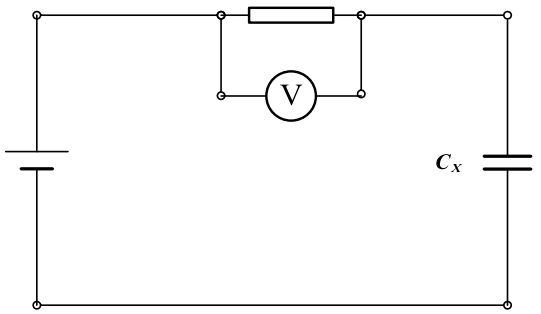
漏电流测试电路 / Circuit for leakage current method	计算方法 / Computing method
	$LC = \frac{U_V}{R} \times 10^3$ <p>LC: 漏电流 / <i>The Leakage current</i> (<i>mA</i>) U_V: 串联电阻两端电压 (<i>V</i>) <i>The voltage between capacitor terminals</i> (<i>V</i>) R: 串联保护电阻 (Ω) <i>The protective resistor</i> (Ω)</p>

8. 注意事项与使用指导 / Handling Precautions and Guidelines

为了确保安全，当设计的设备需使用超级电容器时，请与闻亭实业联系咨询超级电容器的技术规格以及使用要求。

For safety application, please contact Shanghai WTSCAP Co.,Ltd. directly for any technical specifications, handling precautions and guidelines critical to application.

8.1 超级电容器的极性和使用电压 / Polarity and voltage of supercapacitor

(1) 超级电容器具有极性，请勿施加反向的电压或者交流电压。若长时间施加反向电压的话不仅会缩短其使用寿命，还可能造成漏液等致命伤害。

Supercapacitor have polarities, Do not apply a reverse or AC voltage. If a reversed voltage is applied to a capacitor for a long period of time, then its life will be reduced and critical failures may occur such as electrolyte leakage.

(2) 超级电容器的额定电压为超级电容器正常工作可使用的最高电压，所以超级电容器两端请勿施加高过额定电压的电压，在高电压下使用不仅会缩短使用寿命，还会因电化学反应造成气体发生量增加，漏液，破裂等致命故障。

Do not apply an over-voltage (a voltage exceeding the rated voltage), If over-voltage is applied to the capacitor for a long time, then its life will be reduced and critical failures such as electrolyte leakage or physical damage due to gas generated by electrochemical reaction or explosion may occur.

8.2 超级电容器在有纹波电流流经电路的使用 / Circuits through which ripple currents pass:

(1) 超级电容器内部电阻要比其它电解电容器高，纹波电流会使其发热，在预测使用寿命时要加入考虑范围；

(2) 请在加上纹波电流造成的电压变动部分的最大使用电压以下使用；

(3) 超级电容器内部电阻较高，一般不适用于纹波吸收，请用符合用途的低内阻产品。

When using a supercapacitor in a circuit through which ripple currents pass, monitor the allowable temperature rang. The internal resistance of electric supercapacitors is higher than that of electrolytic capacitors. Supercapacitors may generate heat due to ripple currents.

8.3 周围温度对超级电容器的影响 / Effect of ambient temperature on the supercapacitor

超级电容器的使用寿命受使用温度的影响，一般情况下，使用温度降低 10℃，超级电容器的使用寿命会延长 2 倍，请尽量在低于最高使用温度的低温环境下使用。超过最高使用温度使用的话，可能会造成特性急剧劣化，破损。超级电容器的使用温度不仅要确认设备周围温度，内部温度，还要确认设备内发热体（功率晶体管、电阻等）的放射热，纹波电流引起的自行发热温度。此外，还请勿将发热体安装在超级电容器的背面。

Supercapacitor life is affected by usage temperatures. Generally speaking, supercapacitor life is approximately doubled when the temperature is decreased by 10°C. Please use in an environment below the maximum operating temperature. Using supercapacitors beyond the maximum operating temperature may cause rapid deterioration of their characteristics and cause them to break down. The temperature referred to here includes the ambient temperature within the equipment, the heat produced by heat generating devices (power transistor, resistors, etc.), self-heating due to ripple currents, etc. Take all of these factors into consideration when checking the supercapacitor's temperature. Do not place any heat generating devices on the back of the supercapacitor.

8.4 作为后备电源时的电压降 / Voltage drop

当主电源关闭时，超级电容器将从电源失效检验模式转为后备电源工作模式，此时由于瞬间启动电流及电容内阻将导致开路电压下降。请根据相关产品介绍中所列出的阻抗和使用电流确定正确的产品型号。

Pay particular attention to the instantaneous working current and voltage drop due to the supercapacitor's internal resistance when used in backup power operation. Please determine the correct product model based on the impedance and usage current listed in the relevant product introduction.

8.5 串联 / Series connection

串联超级电容器时要保证电压平衡，可考虑使用均压保护电路，保证产品电压低于额定电压使用。

When connecting supercapacitors in series, add a bleeder resistor in parallel with each supercapacitor by taking the leak current into consideration so that the balanced of voltages is not disrupted.

8.6 超级电容器的焊接 / Solder of supercapacitor

在印刷电路板焊接超级电容器产品时，如果超级电容器热过度应激的话，不仅其电气特性劣化，而且还会因气密性不良以及内压上升造成漏液，短路等超越外观的致命故障，请遵守以下内容：

When soldering a supercapacitor to a printed circuit board, excessive heat stress could cause the deterioration of the supercapacitor's electrical characteristics. For example, the integrity of the seal can be compromised, causing the electrolyte to leak, and short circuits could occur in addition to failure of appearance:

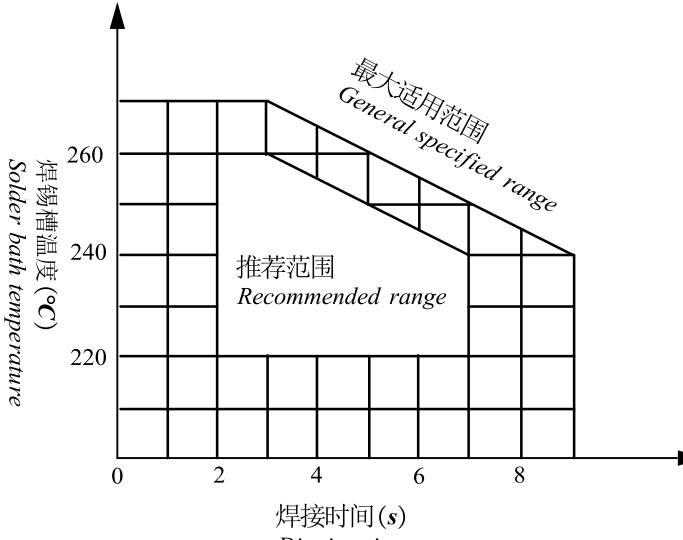
焊接方式	方法
手工焊 / Manual soldering	1) 烙铁请勿接触到产品主体; Do not touch the supercapacitor body with a soldering iron; 2) 请将烙铁的温度控制在 350 °C 以下，焊接持续时间小于 4s，如果连续焊接作业，请预留 15 秒的时间间隔在 3 次内焊接完成。 Solder the capacitor using a soldering tip temperature of 350°C or less for 4 seconds or less. Solder the capacitor three times or less at intervals of 15 seconds or more.
波峰焊 / Peak soldering	1) 焊接时超级电容器请勿接触焊锡槽; Do not dip the body of the supercapacitors into a soldering bath; 2) 焊接时请将产品主体温度控制在 100 °C 60 秒以内，峰值温度 105 °C 以内进行; Keep the supercapacitor's surface temperature at or below 100°C for no more than 60 seconds(the peak 105°C) when soldering; 3) 标准条件如下图所示。 Refer to the chart below to set soldering conditions.  <p>预热温度: 110°C 以下 (基板表面温度) 100°C 以下 (产品实体温度) Pre - heating temperature: 110°C or under (on the surface or circuit board), 100°C or under (on the surface of supercapacitor) 预热时间: 60s 以下 Pre - heating time: 60seconds or under 基板厚度: 0.8mm 以上 Board thickness: 0.8mm or more</p>

备注 / Note

- 1) 使用硬化烤箱烘烤电路板, 固定树脂时, 请将产品表面温度控制在 100 °C 以下 (最高 105 °C), 时间在 60 秒以内此外, 残余电压在 0.3V 以下;
Keep the supercapacitor's surface temperature at or below 100°C for no more than 60 seconds (the peak 105°C) when applying heat to bake the PCB or fixing resin, etc. The residual voltage must be 0.3V or less;
- 2) 在电路板上焊接过一次的产品拆下后请勿再使用, 拆卸可能会发生热应激, 进行手焊修正时请遵照电烙铁焊接要求;
Do not use the product that has been soldered on the circuit board once after removing it, thermal stress may occur when disassembling, please follow the soldering iron soldering requirements when making hand soldering corrections;
拆卸, 修正超级电容器周围的零部件时, 注意不要让超级电容器过度受热;
Be sure not to subject the supercapacitor to excessive heat stress when other parts in its surroundings are detached or adjusted;
- 3) 为提高可焊接性, 引线、焊脚上通常会有镀锡层, 加工过程中损伤镀锡层会造成产品的可焊接性降低;
The lead wires and terminals are tin-plating for solderability. Rasping lead wires or terminals may damage the tin-plating layer and degrade the solderability;
- 4) 对引线/焊脚施加强力的话, 可能会引起引线/焊脚断裂, 造成产品性能降低或者失效。
Excessive force on the leads or terminals can cause them to fracture, resulting in reduced performance or failure

8.7 超级电容器安装使用后的注意事项 / Precautions for using supercapacitor equipment

请勿在下列环境中使用装有超级电容器的设备:

Avoid using equipment with ultracapacitors in the following environments:

- (1) 水、盐水以及油会直接接触到超级电容器的环境;
Supercapacitors are exposed to water, salt water or oil.
- (2) 光直接照射到超级电容器的环境;
Supercapacitors are exposed to direct sunlight.
- (3) 高湿状态下, 容易在超级电容器表面形成露水的环境;
Supercapacitors are exposed to high-humidity where water can condense on the supercapacitor surface.
- (4) 超级电容器会接触到各种活性气体的环境;
Supercapacitors are exposed to various active gases;
- (5) 空气中充满酸、碱的环境;
Supercapacitors are exposed to acidic or alkaline environments;
- (6) 高频感应环境;
Supercapacitors are subject to high-frequency induction;
- (7) 过度振动, 冲击的环境。
Supercapacitors are subject to excessive vibrations or mechanical impact.

8.8 发生紧急情况时注意事项 / Emergency procedures

超级电容器发生异常发热的情況时，会从外封装树脂里面产生烟雾。因此应迅速将设备主电源切断终止使用。此外，超级电容器处于高温状态时，请勿将脸部、手等身体部位接近超级电容器，以免造成烫伤。

If the supercapacitors generate heat, then smoke may come out of the exterior resin. Under these conditions turn off the equipment immediately and stop using it.

Do not place your face or hands close to the supercapacitor, burns may be caused.

8.9 超级电容器的维护和保存 / Maintenance and storage of supercapacitors

8.9.1 超级电容的维护 / Maintenance of supercapacitor

如果超级电容器长时间没有使用，建议每隔 3 个月（最长不建议超过 6 个月）充放电 5 次进行维护。

If the supercapacitor has not been used for a long time, it is recommended to charge and discharge it 5 times every 3 months (not more than 6 months) for maintenance.

8.9.2 超级电容器的保存 / Storage of supercapacitor

请勿将超级电容器保存在高温、高湿的环境中，建议在温度 $25 \pm 10^\circ\text{C}$ ，相对湿度小于 80% 的环境中且包装完好的状态下保存（建议保存期限不要超过 6 个月）。

Do not store supercapacitors in a high-temperature or high-humidity environment. Store supercapacitor at a room temperature of $25 \pm 10^\circ\text{C}$ and a relative humidity of 80% or less (It is recommended that the storage period should not exceed 6 months).

请勿在以下环境中保存：

Avoid storing capacitors under the following conditions:

(1) 水接触到超级电容器或高温高湿，产生结露的环境；

Exposed to water, high temperatures or humidity, or when condensation can occurs;

(2) 油接触到超级电容器或充满油成分空气的环境；

Exposed to oil or in environments filled with gaseous oil contents;

(3) 盐水接触到超级电容器或充满盐分的环境；

Exposed to salt water or environments filled with saline substances;

(4) 充满酸性有害气体（硫化氢、亚硫酸、氯气、溴、甲基溴等）的环境；

In environments filled with harmful gases (hydrogen disulfide, sulfurous acid, nitrous acid, chlorine, bromine, bromomethane, etc.);

(5) 酸性、碱性溶剂会接触到的环境；

Exposed to acid or alkaline solvents;

(6) 直射阳光，臭氧，紫外线以及放射线直接照射的环境；

Exposed to direct sunlight, ozone, ultraviolet or radial rays;

(7) 会给超级电容器带来振动冲击的环境。

Exposed to vibrations or mechanical impact.

8.10 超级电容器的报废 / Discarding of supercapacitor

超级电容器由各种金属、树脂构成，因此报废时请按工业废弃物处理。

Dispose of supercapacitor as industrial waste. They are comprised of various metals and resin.

9. 免责声明 / Products Disclaimer

产品使用前，请用户仔细阅读本产品规格书，上海闻亭实业有限公司对因没有按本规格书规定操作而导致的意外不负责任。若出现产品使用方法错误、电路连接不对或采用的输入电源产品说明书所标性能参数不符等现象均属使用不当，由使用不当造成产品、负载及周边连接件的损坏（人身安全），本公司均不承担相关责任。在不改变产品性能的情况下，产品如有升级，恕不另行通知。

上海闻亭实业有限公司对本说明书的内容保留更改的权利，内容如有变动，恕不另行通知；该资料的最终解释权归本公司所有。

Before using the supercapacitor, please read the specifications, usage instruction and some attentions carefully. Shanghai WTSCAP Co,Ltd. is not responsible for the incident caused by not obeying the Manual. The phenomenon such as incorrect using method or wrong circuit connection, working index are inconsistent with the Manual, cause damage to product, over load and its accessories, we are not responsible for it. Without changing the performance of the product, any upgrades to the product will be made without prior notice.

Shanghai WTSCAP Co,Ltd. has the right to change the content of specification without prior notice. The final explanation of specification belongs to Shandong Goldencell Energy Technology Co., Ltd.

Email: service@wtscap.com