

REVISIONS					
REV.	ECN NO.	LOCATION	DESCRIPTION	DATE	DESIGN
A1	N/A			2025.07.01	
A2	ECN-P-2026031705	(A)X3		2026.03.17	

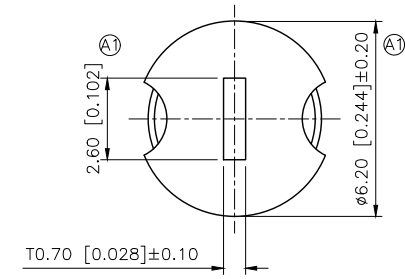
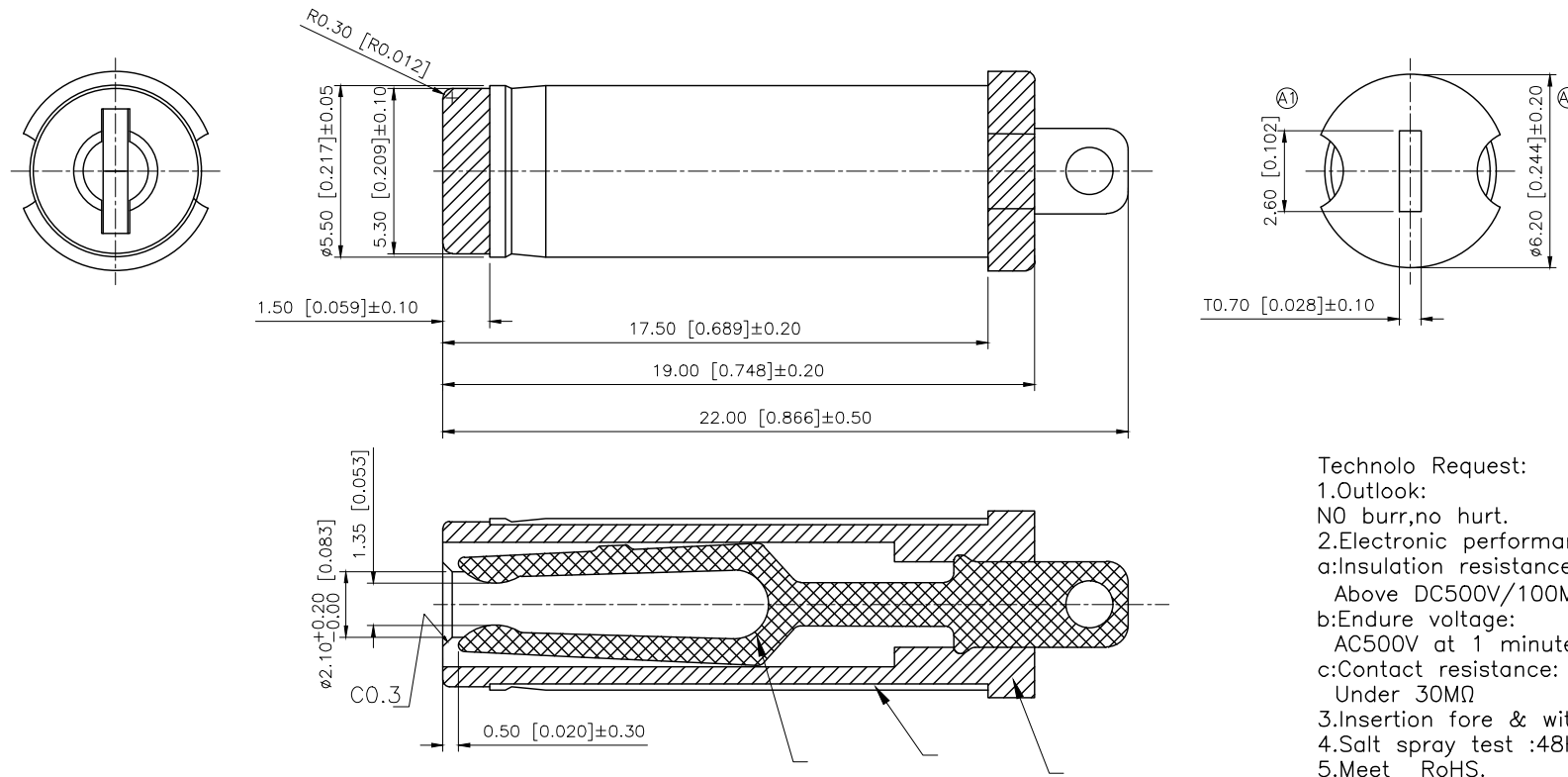

Technolo Request:

- 1.Outlook:  
NO burr,no hurt.
- 2.Electronic performance:  
a:Insulation resistance:  
Above DC500V/100MΩ  
b:Endure voltage:  
AC500V at 1 minute;  
c>Contact resistance:  
Under 30MΩ
- 3.Insertion fore & withdrawal force;0.3–3kgf.
- 4.Salt spray test :48H. (A)
- 5.Meet RoHS.
- 6.Remark \* is important specification

AuGLAR	±5°
X.	±0.40
X.x	±0.30
X.xx	±0.20
X.xxx	±0.15
UNSPECIFIED TOLERAUCES	



DESIGN	VIEW:	MODEL TYPE: DC PLUG
CHECKED	UNIT: mm/in	PART NO.: DT-2255521
APPROVED	SIZE: A4	DWG NO.: