

1. Introduction

The BMP388 is a miniaturized Digital Barometric Air Pressure Sensor with a high accuracy and a low current consumption. The BMP388 is both a pressure and a temperature sensor. The pressure sensor element is based on a capacitive sensing principle which guarantees a high precision during temperature changes. The small package makes the BMP388 ideal for mobile applications and wearable devices.

The BMP388s internal signal processor converts the output from the pressure and temperature sensor elements to 24-bit results. Each pressure sensor has been calibrated individually and contains calibration coefficients. The coefficients are used in the application to convert the measurement results to true pressure and temperature values.

The BMP388 has a FIFO that can store the latest 32 measurements. By using the FIFO, the host processor can remain in a sleep mode for a longer period of time between readouts. This can reduce the overall system power consumption. Sensor measurements and calibration coefficients are available through the serial I2C or SPI interface.

Key features

- Pressure range: 300 ... 1100hPa (+9000m ... -500m relating to sea level)
- Temperature Range: -40...+85°C
- Supply voltage: 1.7 ... 3.6V (VDD), 1.08... 3.6V (VDDIO)
- Package: LGA package with metal lid
Small footprint: 2.0mm x 2.0mm; Super-flat:0.76mm
- Relative accuracy: typ.±0.03hPa, equiv. to ±0.25 m
- Absolute accuracy: typ. ±0.5hPa (300 ... 1100hPa)
- Temperature accuracy: typ. ± 1°C.
- Pressure temperature sensitivity: typ. 0.5Pa/K
- Measurement time: 3.6ms for low precision mode
- Average current consumption: 1.7 µA for pressure measurement, 1.5 µA for temperature measurement at 1Hz sampling rate, 1x oversampling rate, Standby: 0.5 µA
- I2C and SPI interface, Embedded 24-bit ADC
- FIFO: Stores latest 32 pressure or temperature measurements
- Pb-free, halogen-free and RoHS compliant
- MSL 1

Typical applications

- Enhancement of GPS navigation (dead-reckoning, slope detection, etc.)
- In-door and out-door navigation
- Leisure and sports
- Weather forecast
- Vertical velocity indication (rise/sink speed)

Specific notes

Particles can influence the performance of the pressure sensor, we strongly recommend you to introduce special measures to avoid deposition of particles on the MEMS membrane or screen particles after assembly as the assembly process is considered to be the main root cause for particle generation.

2. Absolute maximum ratings

Table 1: Absolute maximum ratings

Parameter	Condition	Min	Max	Units
Storage temperature		-40	+125	°C
Supply Voltage	All pins		+4	V
Voltage at all IO Pins	All pins		+4	V
ESD rating	JESD22-A114	-2	+2	kV
Overpressure			10000	hPa

3. Electrical characteristics

VDD = 1.8V, VDDIO=1.8V, T=25°C, unless otherwise noted. If not stated otherwise, the minimum/maximum values are ± 3 -Sigma values in the given operation mode.

Table 2: Operating conditions, output signal and mechanical characteristics

Parameter	Symbol	Condition	Min	Typ	Max	Units	
Operating temperature	TA	Operational	-40	25	85	°C	
		Full accuracy	0	25	65	°C	
Operating Pressure	P		300		1100	hPa	
Supply voltage	VDD		1.7		3.6	V	
Interface supply voltage	VDDIO		1.08		3.6	V	
Supply current (with 1 measurement per second.)	I _{dd}	1 Hz	Low Power		3	5	μA
			Standard		11	15	
			High precision		40	50	

Note: The current consumption depends on both pressure measurement precision and rate. Please refer to the Pressure Configuration (PRS_CFG) register description for an overview of the current consumption in different combinations of measurement precision and rate.

Peak current	I _{peak}	During conversion		400	500	μA
Standby current	I _{ddsbm}			0.5	1	μA
Relative accuracy pressure	P _R	950...1050hPa +25...+40°C	-6	±3	6	Pa
			-0.5	±0.25	0.5	m
Absolute accuracy pressure	P _A	300...1100hPa 0...+65°C	-3	±0.5	3	hPa
Resolution of output data		Pressure	0.04	0.06	0.07	Pa
		Temperature	0.00056		0.00063	°C
Noise in pressure	P _{Noise}	Low Power mode		1	4	PaRMS
		Standard mode		0.5	1.2	
		High precision mode		0.3	0.6	

Note: Pressure noise is measured as the average standard deviation. Please refer to the Pressure Configuration (PRS_CFG) register description for all precision mode options.

Offset temperature coefficient	TCO	1000hPa +25...+40°C	-1	± 0.5	1	Pa/K
			-8.4	± 4.2	8.4	cm/K
Absolute accuracy temperature		0...+65°C	-3	± 1	3	°C
Pressure/Temperature measurement rate	f		1		200	Hz
Pressure measurement time	t	Low Power mode		5	8	ms
		Standard mode		28	35	
		High precision mode		105	115	

Note: The pressure measurement time (and thus the maximum rate) depends on the pressure measurement precision. Please refer to the Pressure Configuration (PRS_CFG) register description for an overview of the possible combinations of measurement precision and rate.

Supply voltage ramp-up time	t _{vddup}	Time for supply voltage to reach 90% of final value	0.001		5	ms
Serial data clock	f _{I2C}	For I2C			3.4	MHz
	f _{SPI}	For SPI			10	MHz
Long term stability		12month	-0.7	± 0.5	0.7	hPa
Solder drift		Drift measured 24 hours after reflow.	-1	± 0.3	1	hPa
Time to sensor ready	TSensor_rdy	The SENSOR_RDY bit in the Measurement Configuration register will be set when the sensor is ready			12	ms
Time to coefficients are available	TCoef_rdy	The COEF_RDY bit in the Measurement Configuration register will be set when the coefficients can be read out			40	ms

4. Operation

4.1 Operating Modes

The BMP388 supports 3 different modes of operation: Standby, Command, and Background mode.

- Standby Mode
 - Default mode after power on or reset. No measurements are performed.
 - All registers and compensation coefficients are accessible.

- Command Mode
 - One temperature or pressure measurement is performed according to the selected precision.
 - The sensor will return to Standby Mode when the measurement is finished, and the measurement result will be available in the data registers.
- Background Mode
 - Pressure and/or temperature measurements are performed continuously according to the selected measurement precision and rate. The temperature measurement is performed immediately after the pressure measurement.
 - The FIFO can be used to store 32 measurement results and minimize the number of times the sensor must be accessed to read out the results.

Note: Operation mode and measurement type are set in the Sensor Operating Mode and Status (MEAS_CFG) register.

4.2 Measurement Precision and Rate

Different applications require different measurement precision and measurement rates. Some applications, like weather stations, require lower precision and measurement rates than for instance indoor navigation and sports applications.

The BMP388's measurement precision and rate (in background mode) can be configured to match the requirements of the application in which it is being used. This reduces current consumption of the sensor and the system.

In order to achieve a higher precision, the BMP388 will read the sensor multiple times (oversampling), and combine the readings into one result. This increases the current consumption and the measurement time, which again reduces the maximum measurement rate.

The measurement precision, rate and time is set in the Pressure Configuration (PRS_CFG) and Temperature Configuration (TMP_CFG) registers. The register descriptions contain information about the current consumption and the possible combinations of measurement precision, time, and rate.

Please note that the pressure sensor is temperature dependent. Temperature measurements must be made together with the pressure measurements in order to compensate for the temperature dependency. This reduces the maximum pressure measurement rate, *since*: $\text{Rate}_{\text{temperature}} \cdot \text{Time}_{\text{temperature}} + \text{Rate}_{\text{pressure}} \cdot \text{Time}_{\text{pressure}} < 1 \text{ second}$. Measurement Settings and Use Case Examples contains a table with examples of combinations of pressure and temperature precision and rates for different use cases.

4.3 Sensor Interface

The BMP388 can be accessed as a slave device through either SPI 3-wire, SPI 4-wire, or I2C serial interface

4.3.1 I2C interface

- The sensor's default interface.
- The sensor's address is 0x77 (default) or 0x76 (if the SDO pin is pulled-down to GND)

I2C write

Writing is done by sending the slave address in write mode ($RW='0'$), resulting in slave address 111011X0 ('X' is determined by state of SDO pin). Then the master sends pairs of register addresses and register data. The transaction is ended by a stop condition.

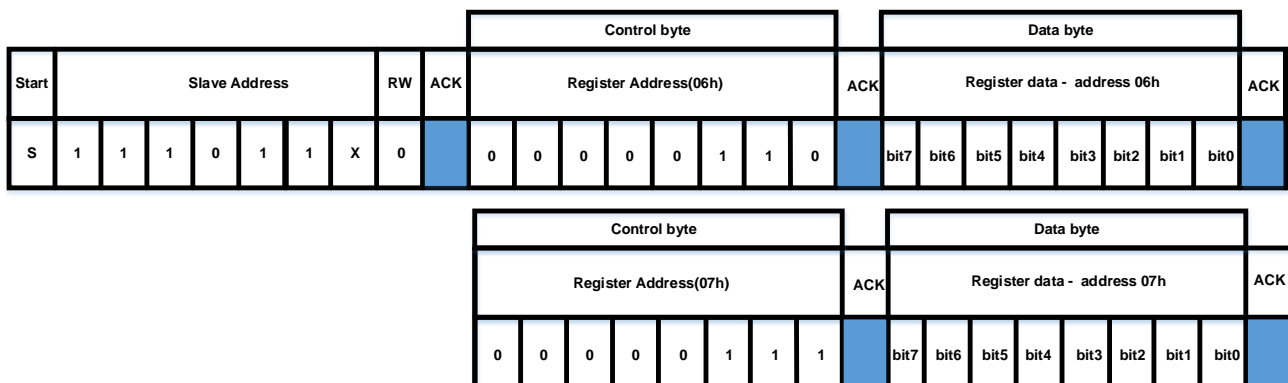

I2C read

To be able to read registers, first the register address must be sent in write mode (slave address 111011X0). Then either a stop or a repeated start condition must be generated. After this the slave is addressed in read mode ($RW='1'$) at address 111011X1, after which the slave sends out data from auto-incremented register addresses until a NOACKM and stop condition occurs.

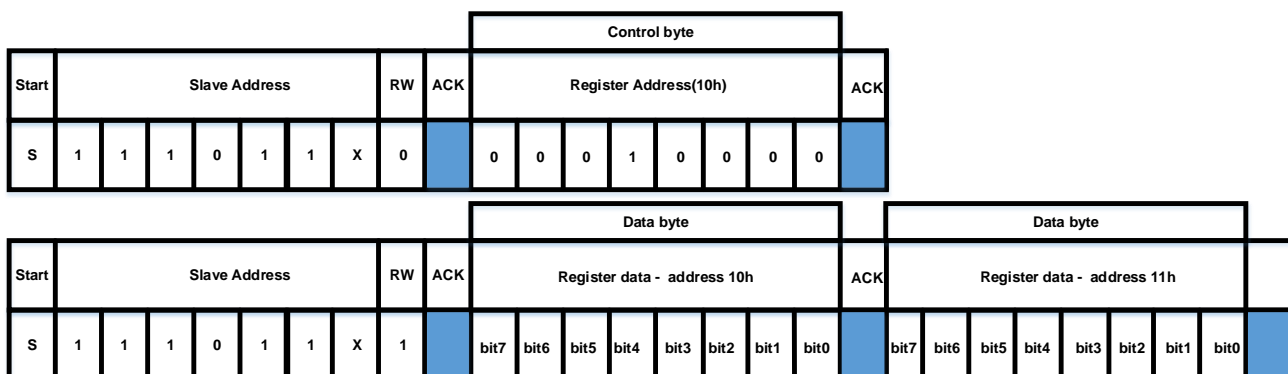

4.3.2 SPI interface

- The sensor will switch to SPI mode, if it detects an active low on the CSB pin. SPI 4-wire is the default SPI interface.
- To enable SPI 3-wire configuration, a bit must be set in the Interrupt and FIFO configuration

(CFG_REG) register after start up.

CSB is active low and has an integrated pull-up resistor. Data on SDA is latched by the device at SCL rising edge and SDO is changed at SCL falling edge. Communication starts when CSB goes to low and stops when CSB goes to high; during these transitions on CSB, SCL must be stable.

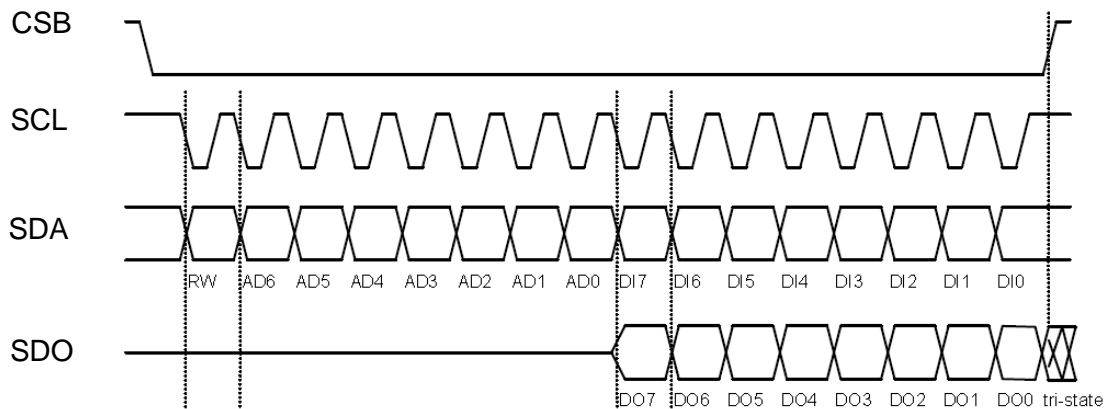

Mode 3(CPOL=1, CPHA=1)

In SPI mode, only 7 bits of the register addresses are used; the MSB of register address is not used and replaced by a read/write bit (RW='0' for write and RW='1' for read).

Example: address 0x10 for read access, the byte 0x90 is transferred, for write access, the byte 0x10 is transferred

SPI write

Writing is done by lowering CSB and sending pairs control bytes and register data. The control bytes consist of the SPI register address (=full register address without bit 7) and the write command (bit7=RW='0'). Several pairs can be written without raising CSB. The transaction is ended by a raising CSB.

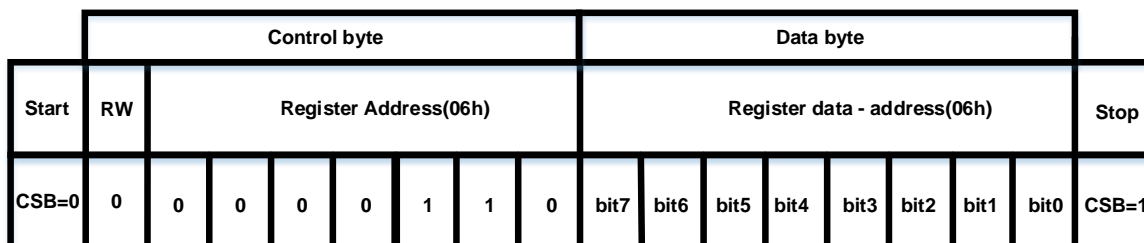

SPI read

Reading is done by lowering CSB and first sending one control byte. The control bytes consist of the SPI register address (= full register address without bit 7) and the read command (bit7=RW='1'). After writing the control byte, data is sent out of the SDO pin (SDA in 3-wire mode); the register address is automatically incremented.

		Control byte								Data byte								Data byte								
Start	RW	Register Address(10h)								Register data - address 10h								Register data - address 11h								Stop
CSB=0	1	0	0	1	0	0	0	0	0	bit7	bit6	bit5	bit4	bit3	bit2	bit1	bit0	bit7	bit6	bit5	bit4	bit3	bit2	bit1	bit0	CSB=1

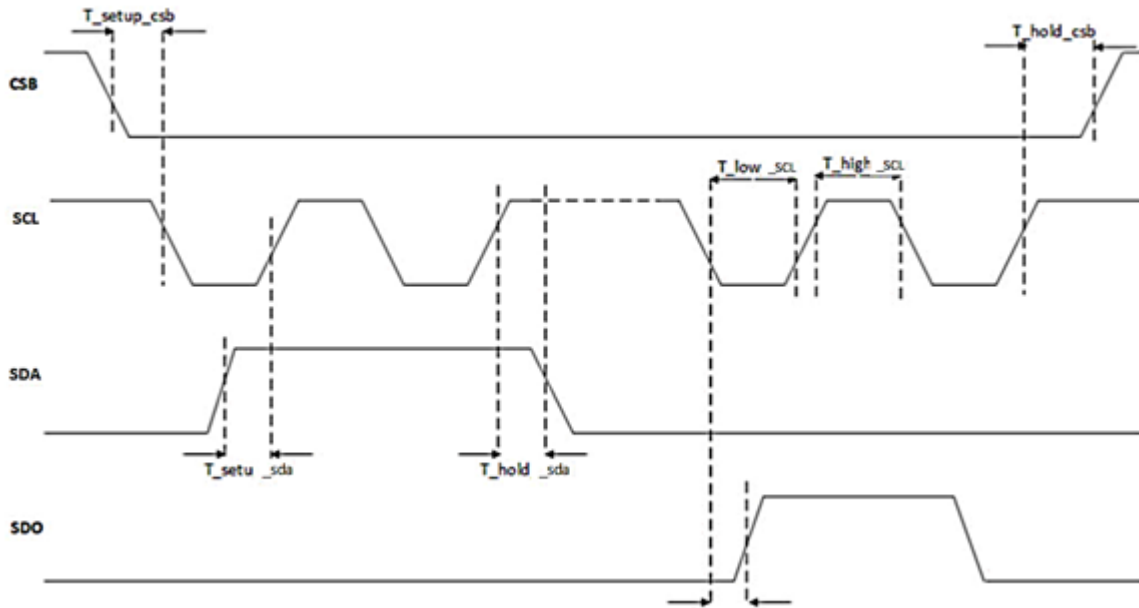
Table 3 SPI timings

Parameter	Symbol	Values			Unit	Note
		Min.	Typ.	Max.		
Duty Cycle	SPI_DC	30			%	$V_{DDIO} = 1.2V$
		20			%	$V_{DDIO} = 1.8V/3.6V$
SDA setup time	T_{setup_sda}	2			ns	
SDA hold time	T_{hold_sda}	2			ns	
Clock	SPI_CLK			10	MHz	
CSB setup time	T_{setup_csb}			30	ns	
CSB setup time	T_{setup_csb}	15			ns	
CSB hold time	T_{hold_csb}	15			ns	

4.4 Interrupt

The BMP388 can generate an interrupt when a new measurement result is available and/or when the FIFO is full. The sensor uses the SDO pin for the interrupt signal, and interrupt is therefore not supported if the interface is 4-wire SPI.

The interrupt is enabled and configured in the Interrupt and FIFO configuration (CFG_REG) register. The SDO pin serves as both interrupt and as the least significant bit in the device address. If the SDO pin is pulled low the interrupt polarity must be set to active high and vice versa.

The interrupt status can be read from the Interrupt Status (INT_STS) register.

4.5 FIFO Operation

The BMP388 FIFO can store the last 32 measurements of pressure or temperature. This reduces the overall system power consumption when the host processor does not need to continuously pull data from the sensor but can go into standby mode for longer periods of time.

The FIFO will store any combination of temperature and pressure measurements since the measurement rate of temperature and pressure can be set up independently in Background Mode. The pressure rate can for instance be set 4 times higher than the temperature rate and thus only every fifth result will be a temperature result. The measurement type can be seen in the result data. The sensor will set the least significant bit to:

- '1' if the result is a pressure measurement.
 - '0' if it is a temperature measurement.
- The sensor uses 24 bits to store the measurement result. Because this is more bits than is needed to cover the full dynamic range of the pressure sensor, using the least significant bit to label the measurement type will not affect the precision of the result.

The FIFO can be enabled in the Interrupt and FIFO configuration (CFG_REG) register. The data from the FIFO is read out from the Pressure Data (PRS_Bn) registers regardless of the next result in the FIFO is a temperature or a pressure measurement.

When a measurement has been read out, the FIFO will auto increment and place the next result in the data register. A flag will be set in the FIFO Status (FIFO_STS) register when the FIFO is empty and all following reads will return 0x800000.

If the FIFO runs full a flag will be set in the FIFO Status (FIFO_STS) register and the sensor will generate an interrupt if this has been enabled in the Interrupt and FIFO configuration (CFG_REG) register.

4.6 Calibration and Measurement Compensation

The BMP388 is a calibrated sensor and contains calibration coefficients. These are used in the

application (for instance by the host processor) to compensate the measurement results for sensor non-linearity's.

The sections that follow, describe how to calculate the compensated results and convert them into Pa and °C values.

4.6.1 How to Calculate Compensated Pressure Values

1. Read the calibration coefficients (c00, c10, c20, c30, c40, c01, c11, c21 and c31) from the Calibration Coefficient register.

Note: The coefficients c00 and c10 are 20 bit 2's complement numbers, c20, c30, c01, c11, c21 are 16 bit 2's complement numbers and c31, c40 are 12 bit 2's complement numbers.

2. Choose scaling factors kT (for temperature) and kP (for pressure) based on the chosen precision rate. The scaling factors are listed in Table 4.

3. Read the pressure and temperature result from the registers or FIFO.

Note: The measurements read from the result registers (or FIFO) are 24 bit 2's complement numbers.

Depending on the chosen measurement rates, the temperature may not have been measured since the last pressure measurement.

4. Calculate scaled measurement results.

$$T_{raw_sc} = T_{raw}/kT$$

$$P_{raw_sc} = P_{raw}/kP$$

5. Calculate compensated measurement results.

$$P_{comp}(Pa) = c00 + c10 * P_{raw_sc} + c20 * P_{raw_sc}^2 + c30 * P_{raw_sc}^3 + c40 * P_{raw_sc}^4 + T_{raw_sc} * (c01 + c11 * P_{raw_sc} + c21 * P_{raw_sc}^2 + c31 * P_{raw_sc}^3)$$

4.6.2 How to Calculate Compensated Temperature Values

1. Read the calibration coefficients (c0 and c1) from the Calibration Coefficients (COEF) register.

Note: The coefficients read from the coefficient register are 12 bit 2's complement numbers.

2. Choose scaling factor kT (for temperature) based on the chosen precision rate. The scaling factors are listed in Table 4.

3. Read the temperature result from the temperature register or FIFO.

Note: The temperature measurements read from the temperature result register (or FIFO) are 24 bit 2's complement numbers.

4. Calculate scaled measurement results.

$$T_{raw_sc} = T_{raw}/kT$$

5. Calculate compensated measurement results

$$T_{\text{comp}}(^{\circ}\text{C}) = c_0 \cdot 0.5 + c_1 \cdot T_{\text{raw_sc}}$$

4.6.3 Compensation Scale Factors

Table 4 Compensation Scale Factors

Oversampling Rate	Scale Factor (kP or kT)
1 (single)	524288
2 times (Low Power)	1572864
4 times	3670016
8 times	7864320
16 times (Standard)	253952
32 times	516096
64 times (High Precision)	1040384
128 times	2088960

4.6.4 Pressure and Temperature calculation flow

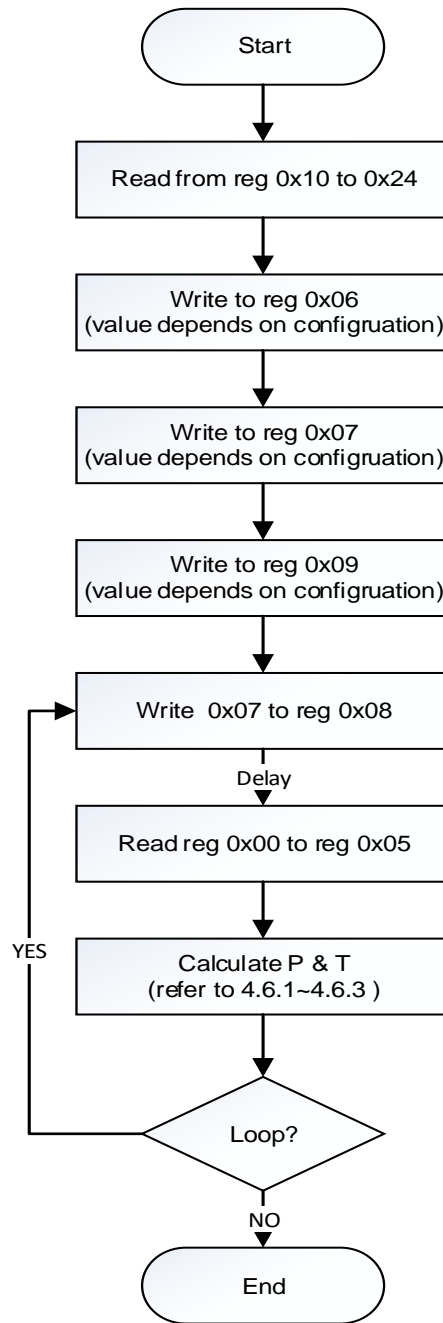

5 Applications

5.1 Measurement Settings and Use Case Examples

Table 5 Measurement Settings and Use Case Examples (TBD)

Use Case	Performance	Pressure Register Configuration Address: 0x06	Temperature Register Configuration Address: 0x07	Other
Weather Station (Low power, Background mode)	5 Pa precision. 1 pr sec. 6 μ A	0x01	0x00	Start background measurements (addr 0x08)
Indoor navigation (Standard precision, Background mode)	10 cm precision. 2 pr sec. 30 μ A	0x14	0x00	Enable P shift (addr 0x09) Start background measurements (addr 0x08)
Sports (High precision, high rate, background mode)	5 cm precision 4 pr sec. 200 μ A	0x26	0x20	Enable P shift (addr 0x09) Start background measurements (addr 0x08)

5.2 Application Circuit Example

The example application circuit example uses the I2C and SPI serial interface. The SDO pin can be used for interrupt or to set least significant bit of the device address.

- In I2C mode, the SDO pin can be used for interrupt output and/or to set the least significant bit of the device address.
- In 3-wire SPI mode, the SDO pin can be used for interrupt output.
- In 4-wire SPI mode, the SDO pin can only be used as the serial data output.

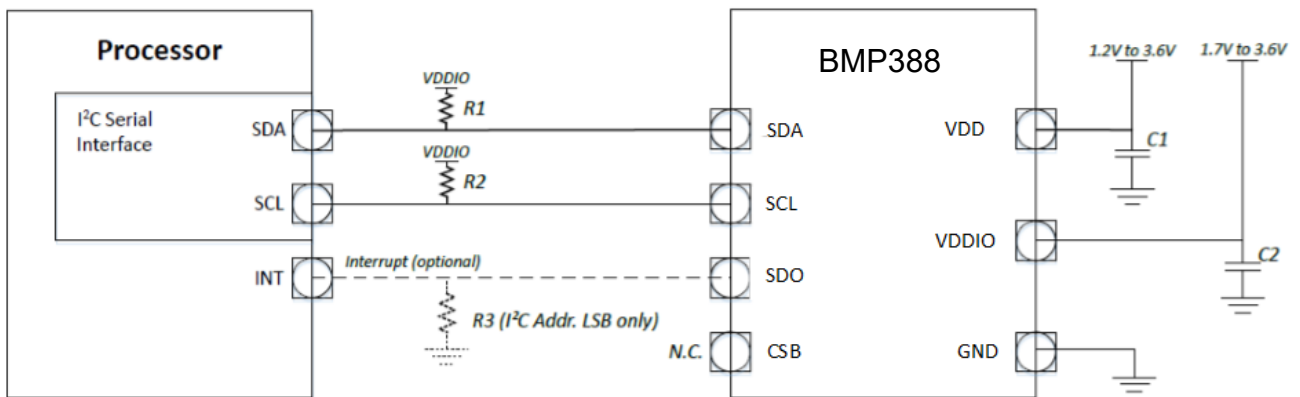

Figure 1: Application circuit example using the I2C serial interface

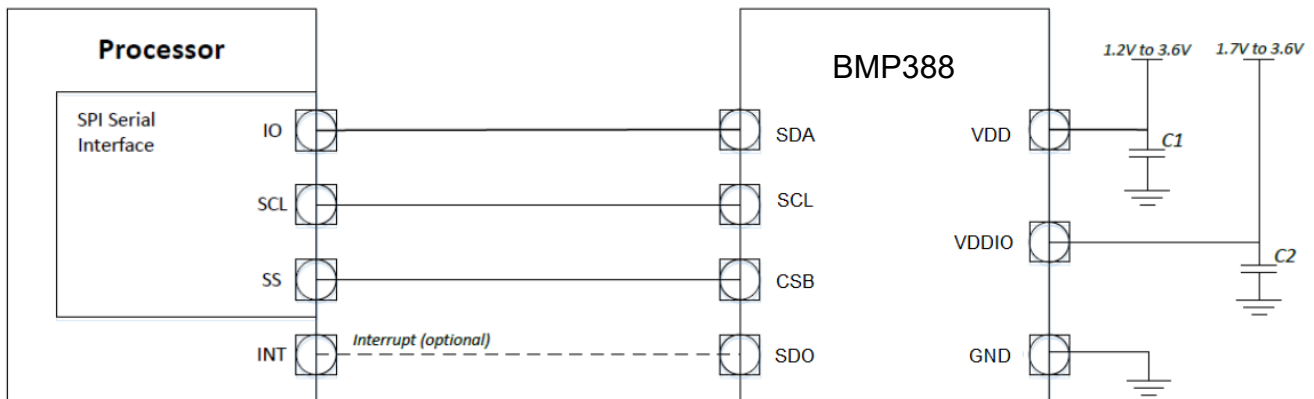

Figure 2: Application circuit example using the SPI 3-wires serial interface

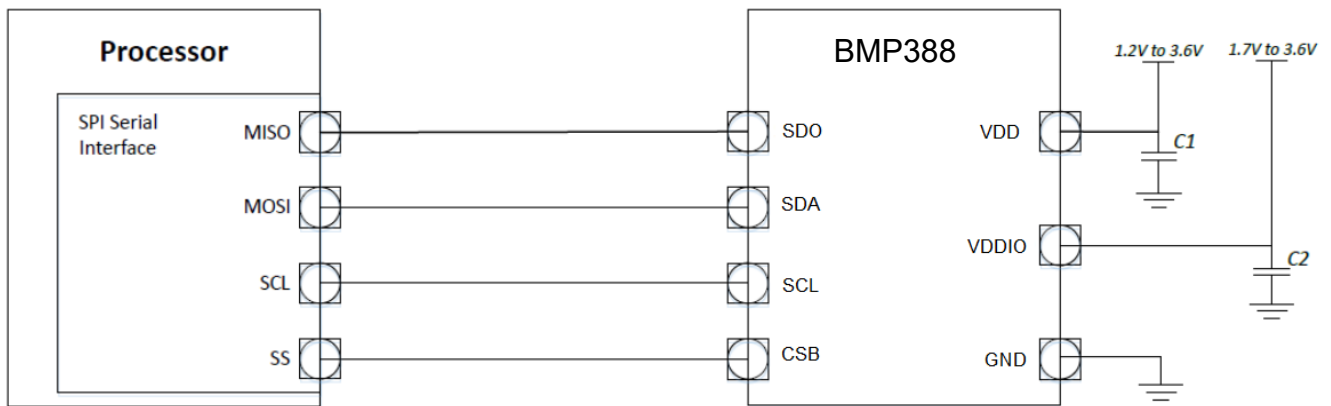

Figure 3: Application circuit example using the SPI 4-wires serial interface

Table 6 Component Values

Component	Symbol	Values			Unit	Note / Test Condition
		Min.	Typ.	Max.		
Pull-up Resistor	R_1, R_2, R_3	2.2	4.7	10	K Ω	
Supply Blocking Capacitor	C_1, C_2		100		nF	The blocking capacitors should be placed as close to the package pins as possible.

5.3 Calculating absolute altitude and calculating pressure at sea level

With the measured pressure P and the pressure at sea level $P_0=1013.25\text{hPa}$, the altitude in meters can be calculated with the international barometric formula:

$$\text{Altitude} = 44330 \times \left[1 - \left(\frac{P}{P_0} \right)^{\frac{1}{5.255}} \right]$$

Thus, a pressure change of $\Delta p = 1\text{hPa}$ corresponds to 8.43m at sea level.

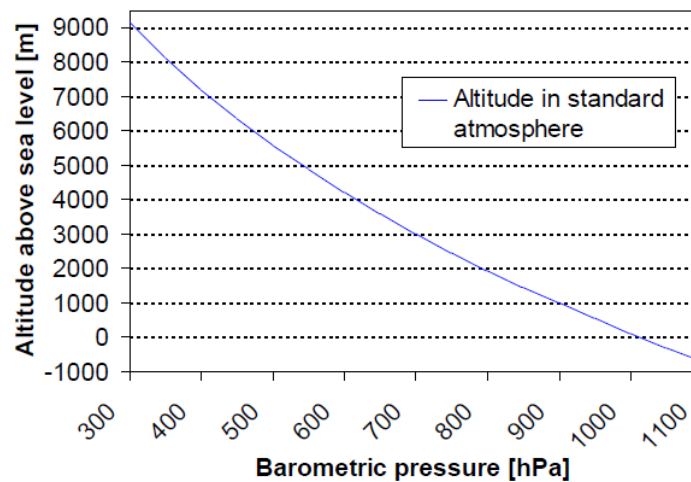

Figure 4: Transfer function: Altitude over sea level – Barometric pressure

With the measured pressure p and the absolute altitude the pressure at sea level can be calculated:

$$P_0 = \frac{p}{\left(1 - \frac{\text{altitude}}{44330} \right)^{5.255}}$$

Thus, a difference in altitude of $\Delta\text{altitude} = 10\text{m}$ corresponds to 1.2hPa pressure change at sea level.

6 Register Map

Table 7 Register Map

Register Name	Addr.	bit7	bit6	bit5	bit4	bit3	bit2	bit1	bit0	Reset State
PSR_B2	0x00	PSR[23:16] (r)								00h
PSR_B1	0x01	PSR[15:8](r)								00h
PSR_B0	0x02	PSR[7:0](r)								00h
TMP_B2	0x03	TMP[23:16] (r)								00h
TMP_B1	0x04	TMP[15:8] (r)								00h
TMP_B0	0x05	TMP[7:0] (r)								00h
PRS_CFG	0x06	PM_RATE [7:4] (rw)				PM_PRC [3:0] (rw)				00h
TMP_CFG	0x07	TMP_RATE [7:4] (rw)				TM_PRC [3:0] (rw)				00h
MEAS_CFG	0x08	COEF_RDY (r)	SENS OR _RDY	TMP _RDY (r)	PRS_RDY (r)	TMP_EXT (rw)	MEAS_CRTL [2:0] (rw)			c0h
CFG_REG	0x09	INT_HL (rw)	INT_SEL [2:0] (rw)			TMP_SHIFT_EN (rw)	PRS_SHIFT_EN (rw)	FIFO_EN (rw)	SPI_MODE (rw)	00h
INT_STS	0x0A	-	-	-	-	-	INT_FIFO_FULL(r)	INT_TMP (r)	INT_PRS (r)	00h
FIFO_STS	0x0B	-	-	-	-	-	-	FIFO_FULL (r)	FIFO_EMPTY (r)	00h
RESET	0x0C	FIFO_FLUSH (w)	-	-	-	SOFT_RST [3:0] (w)			00h	
ID	0x0D	REV_ID [7:4] (r)				PROD_ID [3:0] (r)				11h
COEF	0x10-0x24	< see register description >								XXh

7 Register Description

7.1 Pressure Data (PRS_Bn)

The Pressure Data registers contains the 24 bit (3 bytes) 2's complement pressure measurement value. If the FIFO is enabled, the register will contain the FIFO pressure and/or temperature results (please see FIFO Operation). Otherwise, the register contains the pressure measurement results and will not be cleared after read.

7.1.1 PRS_B2

The highest byte of the three bytes measured pressure value.

PRS_B2	Address	00H
Pressure (MSB data)	Reset value:	00H
7	6	5
4	3	2
1	0	

PRS23	PRS22	PRS21	PRS20	PRS19	PRS18	PRS17	PRS16
-------	-------	-------	-------	-------	-------	-------	-------

r

Field	Bits	Type	Description
PRS[23:16]	7:0	r	MSB of 24 bit 2's complement pressure data.

7.1.2 PRS_B1

The middle byte of the three bytes measured pressure value.

PRS_B1	Address	01H
Pressure (LSB data)	Reset value:	00H
7	6	5
4	3	2
1	0	

PRS15	PRS14	PRS13	PRS12	PRS11	PRS10	PRS9	PRS8-
-------	-------	-------	-------	-------	-------	------	-------

r

Field	Bits	Type	Description
PRS[15:8]	7:0	r	LSB of 24 bit 2's complement pressure data.

7.1.3 PRS_B0

The lowest byte of the three bytes measured pressure value.

PRS_B0	Address	02H					
Pressure (XLSB data)	Reset value:	00H					
7	6	5	4	3	2	1	0

PRS7	PRS6	PRS5	PRS4	PRS3	PRS2	PRS1	PRS0
------	------	------	------	------	------	------	------

r

Field	Bits	Type	Description
PRS[7:0]	7:0	r	XLSB of 24 bit 2's complement pressure data.

7.2 Temperature Data (TMP_Tn)

The Temperature Data registers contain the 24 bit (3 bytes) 2's complement temperature measurement value (unless the FIFO is enabled, please see FIFO Operation) and will not be cleared after the read.

7.2.1 TMP_B2

The highest byte of the three bytes measured temperature value.

TMP_B2	Address	03H
Temperature (MSB data)	Reset value:	00H

7 6 5 4 3 2 1 0

TMP23	TMP22	TMP21	TMP20	TMP19	TMP18	TMP17	TMP16
-------	-------	-------	-------	-------	-------	-------	-------

r

Field	Bits	Type	Description
TMP[23:16]	7:0	r	MSB of 24 bit 2's complement temperature data.

7.2.2 MP_B1

The middle byte of the three bytes measured temperature value.

TMP_B1	Address	04H					
Temperature (LSB data)	Reset value:	00H					
7	6	5	4	3	2	1	0

TMP15	TMP14	TMP13	TMP12	TMP11	TMP10	TMP9	TMP8
-------	-------	-------	-------	-------	-------	------	------

r

Field	Bits	Type	Description
TMP[15:8]	7:0	r	LSB of 24 bit 2's complement temperature data.

7.2.3 TMP_B0

The lowest part of the three bytes measured temperature value.

TMP_B0	Address	05H					
Temperature (XLSB data)	Reset value:	00H					
7	6	5	4	3	2	1	0

TMP7	TMP6	TMP5	TMP4	TMP3	TMP2	TMP1	TMP0
------	------	------	------	------	------	------	------

r

Field	Bits	Type	Description
TMP[7:0]	7:0	r	XLSB of 24 bit 2's complement temperature data.

7.3 Pressure Configuration (PRS_CFG)

Configuration of pressure measurement rate (PM_RATE) and resolution (PM_PRC).

PRS_CFG	Address:	06H
Pressure measurement configuration	Reset value:	00H

7	6	5	4	3	2	1	0
-PM_RATE[3:0]				PM_PRC[3:0]			

-

rw

rw

Field	Bits	Type	Description
PM_RATE[3:0]	7:4	rw	Pressure measurement rate: 0000 - 1 measurements pr. sec. 0001 - 2 measurements pr. sec. 0010 - 4 measurements pr. sec. 0011 - 8 measurements pr. sec. 0100 - 16 measurements pr. sec. 0101 - 32 measurements pr. sec. 0110 - 64 measurements pr. sec. 0111 - 128 measurements pr. sec. 1000 - 25/16 sample/sec 1001 - 25/8 sample/sec 1010 - 25/4 sample/sec 1011 - 25/2 sample/sec 1100 - 25 sample/sec 1101 - 50 sample/sec 1110 - 100 sample/sec 1111 - 200 sample/sec Applicable for measurements in Background mode only
PM_PRC[3:0]	3:0	rw	Pressure oversampling rate: 0000 - Single. (Low Precision) 0001 - 2 times (Low Power). 0010 - 4 times. 0011 - 8 times. 0100 *)- 16 times (Standard). 0101 *) - 32 times. 0110 *) - 64 times (High Precision). 0111 *) - 128 times. 1xxx – Reserved

*) Note: Use in combination with a bit shift. See Interrupt and FIFO configuration (CFG_REG) register

Table 8 Pressure measurement time (ms) and precision (PaRMS)

Oversampling (PRC[3:0])	Single (0000)	2 times (0001)	4 times (0010)	8 times (0011)	16 times (0100)	32 times (0101)	64 times (0110)	128 times (0111)
Measurement time (ms)	3.6	5.2	8.4	14.8	27.6	53.2	104.4	206.8
Precision (PaRMS)	2	1	0.7	0.6	0.5	0.4	0.3	0.3

Table 9 Estimated current consumption (μ A)

Oversampling (PRC[3:0])	Single (0000)	2 times (0001)	4 times (0010)	8 times (0011)	16 times (0100)	32 times (0101)	64 times (0110)	128 times (0111)
Measurements pr sec.(PM_RATE([2:0]))								
1 (0000)	2.6	3.3	4.8	7.7	13.5	25.0	48.1	94.3
2 (0001)								
4 (0010)								
8 (0011)	Note: The current consumption can be calculated as the Measurement Rate * Current Consumption of 1 measurement							n.a.
16 (0100)							n.a.	n.a.
32 (0101)						n.a.	n.a.	n.a.
64 (0110)					n.a.	n.a.	n.a.	n.a.
128 (0111)			n.a.	n.a.	n.a.	n.a.	n.a.	n.a.
200 (1111)		n.a.	n.a.	n.a.	n.a.	n.a.	n.a.	n.a.

Note: The table shows the possible combinations of Pressure Measurement Rate and oversampling when no temperature measurements are performed. When temperature measurements are performed the possible combinations are limited to $\text{Rate}_{\text{temperature}} \times \text{Measurement Time}_{\text{temperature}} + \text{Rate}_{\text{pressure}} \times \text{Measurement Time}_{\text{pressure}} < 1 \text{ second}$.

7.4 Temperature Configuration (TMP_CFG)

Configuration of temperature measurement rate (TMP_RATE) and resolution (TMP_PRC).

TMP_CFG	Address:	07H
Temperature measurement configuration	Reset value:	00H
7	6	5
4	3	2
1	0	

TMP_RATE[3:0]	-TMP_PRC[3:0]
rw	rw

Field	Bits	Type	Description
TMP_RATE[3:0]	7:4	rw	Temperature measurement rate: 0000 - 1 measurement pr. sec. 0001 - 2 measurements pr. sec. 0010 - 4 measurements pr. sec. 0011 - 8 measurements pr. sec. 0100 - 16 measurements pr. sec. 0101 - 32 measurements pr. sec. 0110 - 64 measurements pr. sec. 0111 - 128 measurements pr. sec. 1001 - 25/8 sample/sec 1010 - 25/4 sample/sec 1011 - 25/2 sample/sec 1100 - 25 sample/sec 1101 - 50 sample/sec 1110 - 100 sample/sec 1111 - 200 sample/sec Applicable for measurements in Background mode only
TMP_PRC[3:0]	3:0	rw	Temperature oversampling (precision): 000 - single. (Default) - Measurement time 3.6 ms. Note: Following are optional, and may not be relevant: 0001 - 2 times. 0010 - 4 times. 0011 - 8 times. 0100 - 16 times. 0101 - 32 times. 0110 - 64 times.. 0111 - 128 times. 1xxx – Reserved

7.5 Sensor Operating Mode and Status (MEAS_CFG)

Setup measurement mode.

MEAS_CFG	Address						08H	
Measurement configuration	Reset value:						c0H	
	7	6	5	4	3	2	1	0

COEF_RDY	SENSOR_RDY	TMP_RDY	PRS_RDY	TMP_EXT	MEAS_CTR
r	r	r	r		rw

Field	Bits	Type	Description
COEF_RDY	7	r	Coefficients will be read to the Coefficients Registers after start- up: 0 - Coefficients are not available yet. 1 - Coefficients are available.
SENSOR_RDY	6	r	The pressure sensor is running through self-initialization after start-up. 0 - Sensor initialization not complete 1 - Sensor initialization complete It is recommend not to start measurements until the sensor has completed the self-initialization.
TMP_RDY	5	r	Temperature measurement ready 1 - New temperature measurement is ready. Cleared when temperature measurement is read.
PRS_RDY	4	r	Pressure measurement ready 1 - New pressure measurement is ready. Cleared when procurement measurement is read.
TMP_EXT	3		0 - Internal temperature sensor (of ASIC) recommended 1- External temperature sensor (of pressure sensor MEMS element if any)

MEAS_CTRL	2:0	rw	Set measurement mode and type: Standby Mode 000 - Idle / Stop background measurement Command Mode 001 - Pressure measurement 010 - Temperature measurement 011 - na. 100 - na. Background Mode 101 - Continuous pressure measurement 110 - Continuous temperature measurement 111 - Continuous pressure and temperature measurement
-----------	-----	----	--

7.6 Interrupt and FIFO configuration (CFG_REG)

Configuration of interrupts, measurement data shift, and FIFO enable.

CFG_REG	Address							09H
Configuration register	Reset value:							00H
	7	6	5	4	3	2	1	0

INT_HL	INT_FIFO	INT_TMP	INT_PRS	T_SHIFT	P_SHIFT	FIFO_EN	SPI_MODE
rw	rw	rw	rw	rw	rw	rw	rw

Field	Bits	Type	Description
INT_HL	7	rw	Interrupt (on SDO pin) active level: 0 - Active low. 1 - Active high.
INT_FIFO	6	rw	Generate interrupt when the FIFO is full: 0 - Disable. 1 - Enable.
INT_TMP	5	rw	Generate interrupt when a temperature measurement is ready: 0 - Disable. 1 - Enable.

INT_FIFO_FULL	2	r	Status of FIFO interrupt 0 - Interrupt not active 1 - Interrupt active
INT_TMP	1	r	Status of temperature measurement interrupt 0 - Interrupt not active 1 - Interrupt active
INT_PRS	0	r	Status of pressure measurement interrupt 0 - Interrupt not active 1 - Interrupt active

7.8 FIFO Status (FIFO_STS)

FIFO status register

FIFO_STS	Address	0BH					
FIFO status register	Reset value:	00H					
7	6	5	4	3	2	1	0

-	FIFO_ FULL	FIFO_ EMPTY
-	r	R

Field	Bits	Type	Description
-	7:2	-	Reserved.
FIFO_FULL	1	r	0 - The FIFO is not full 1 - The FIFO is full
FIFO_EMPTY	0	r	0 - The FIFO is not empty 1 - The FIFO is empty

7.9 Soft Reset and FIFO flush (RESET)

Flush FIFO or generate soft reset.

RESET	Address:	0CH
FIFO flush and soft reset	Reset value:	00H

Table 10 Calibration Coefficients

Coefficient	Addr.	bit7	bit6	bit5	bit4	bit3	bit2	bit1	bit0
c0	0x10	c0 [11:4]							
c0/c1	0x11	c0 [3:0]				c1 [11:8]			
c1	0x12	c1[7:0]							
c00	0x13	c00 [19:12]							
c00	0x14	c00 [11:4]							
c00/c10	0x15	c00 [3:0]				c10 [19:16]			
c10	0x16	c10 [15:8]							
c10	0x17	c10 [7:0]							
c01	0x18	c01 [15:8]							
c01	0x19	c01 [7:0]							
c11	0x1A	c11 [15:8]							
c11	0x1B	c11 [7:0]							
c20	0x1C	c20 [15:8]							
c20	0x1D	c20 [7:0]							
c21	0x1E	c21 [15:8]							
c21	0x1F	c21 [7:0]							
c30	0x20	c30 [15:8]							
c30	0x21	c30 [7:0]							
C31	0x22	c31 [11:4]							
C40	0x23	c31 [3:0]				C40 [11:8]			
C40	0x24	C40 [7:0]							

8 Mechanical characteristics

8.1 Pin configuration

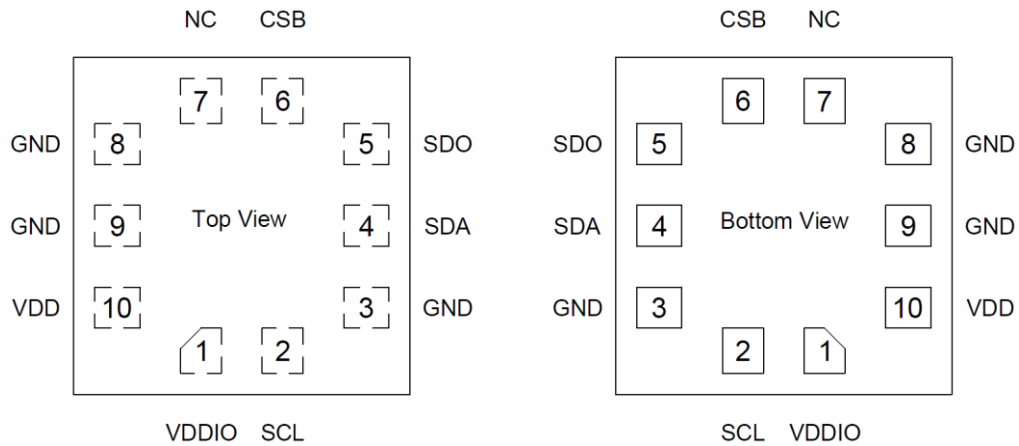

Figure 5: Layout pin configuration BMP388

Table 11: Pin configuration of BMP388

Pin	Name	SPI 3-wire	SPI 3-wire with interrupt	SPI 4-wire	I2C	I2C with interrupt
1	VDDIO	Digital supply voltage for digital blocks and I/O interface				
2	SCL	Serial Clock				
3	GND	Ground				
4	SDA	Serial data in/out	Serial data in/out	Serial data in	Serial data in/out	Serial data in/out
5	SDO	Not used	Interrupt	Serial data out	Least significant bit in the device address	Interrupt pin and least significant bit in the device address
6	CSB	Chip select – active low	Chip select – active low	Chip select – active low	Not used - open (internal pull-up) or tie to VDDIO	Not used - open (internal pull- up) or tie to VDDIO
7	NC	Not connected				
8,9	GND	Ground				
10	VDD	Supply voltage for analog blocks				

8.2 Outline dimensions

The sensor housing is a 10 Pin LGA package with metal lid. Its dimensions are 2.0 x 2.0 x 0.76 mm (typ.), undeclared tolerance are ± 0.05 mm.

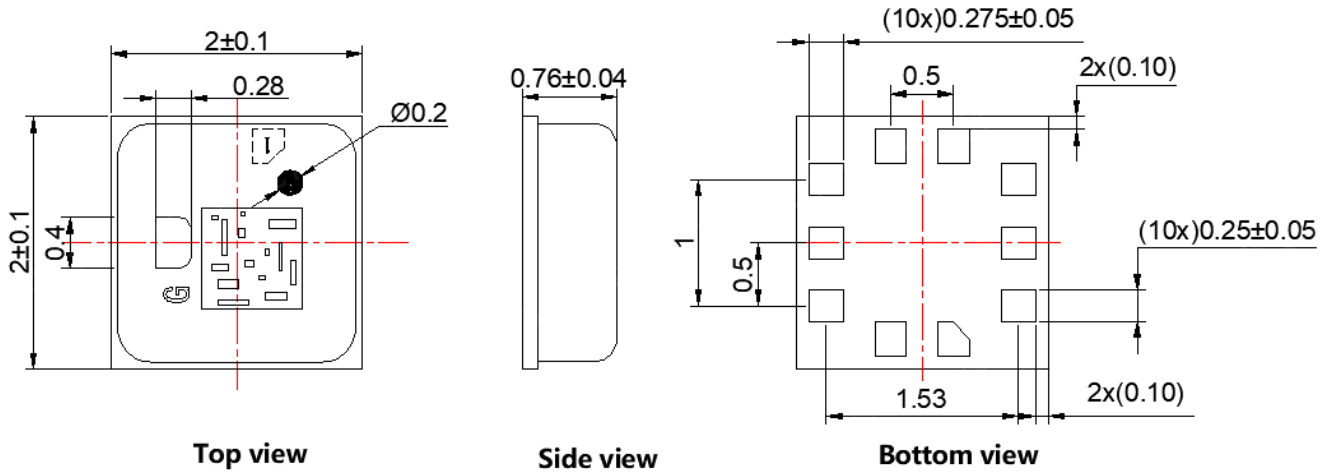

Figure 6: Top view and bottom view of BMP388

9 Storage and transportation

- Keep in warehouse with less than 75% humidity and without sudden temperature change, acid air, any other harmful air or strong magnetic field.
- The MEMS pressure sensor with normal pack can be transported by ordinary conveyances. Please protect products against moist, shock, sunburn and pressure during transportation.
- Storage Temperature Range: $-40^{\circ}\text{C} \sim +125^{\circ}\text{C}$
- Operating Temperature Range: $-40^{\circ}\text{C} \sim +85^{\circ}\text{C}$

10 Soldering recommendation

Recommended Solder Reflow

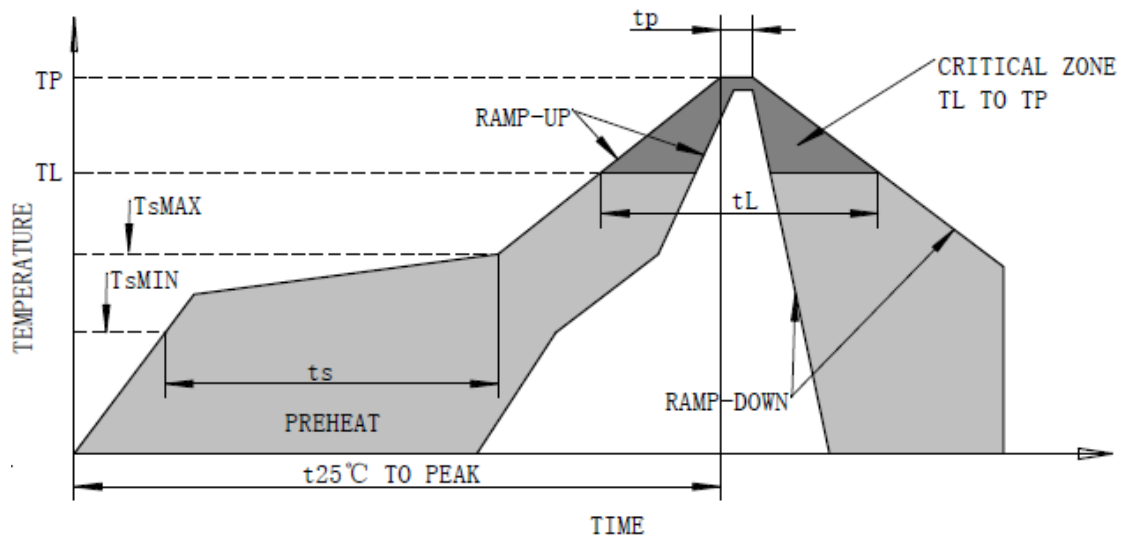

Profile Feature	Pb-Free Assembly
Average ramp-up rate(T_{sMAX} to T_P)	$3^{\circ}\text{C}/\text{seconds max.}$
Preheat	
-Temperature Min.(T_{sMIN})	150°C
-Temperature Max.(T_{sMAX})	200°C
-Time(T_{sMIN} to T_{sMAX})(T_s)	$60 \sim 80\text{seconds}$
Time maintained above:	
-Temperature(T_L)	217°C
-Time(t_L)	$60 \sim 150\text{seconds}$
Peak temperature(T_P)	260°C
Time within 5°C of actual peak temperature(T_P) ²	$20 \sim 40\text{seconds}$
Ramp-down rate	$4^{\circ}\text{C}/\text{seconds max.}$
Time 25°C to peak temperature	8 minutes max.

11 Package Specifications

Carrier Tape Information [Unit: mm]

Quantity per reel: 10kpcs.

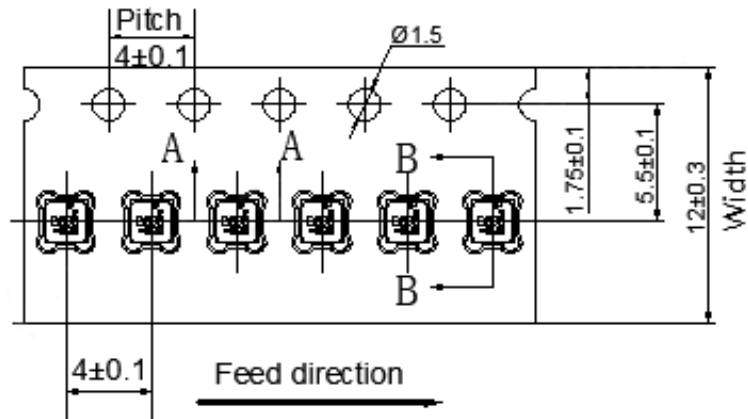

A-A 2:1

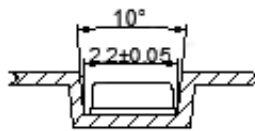

B-B 2:1

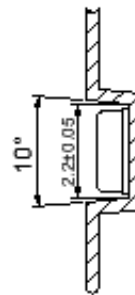

Direction

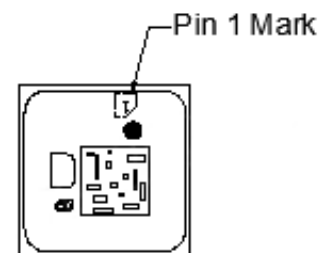

Figure 7: Carrier Tape