

## 5.5V, 2.5A Low Loss Power Distribution Switch

### Features

- Input voltage: 2.7V to 5.5V
- Typical 70mΩ on-resistance
- 2.5A load current capability
- Programmable current limit
- Enable polarity:  
STMPS2151STR: Active high  
STMPS2151ST: Active Low
- Over current protection, short circuit protection and over temperature protection
- Reverse blocking (no body diode)
- No reverse current when power ON or power OFF
- Compact SOT23-5 package minimizes the board space

### Applications

- USB Ports/Hubs
- Digital TV
- Set-Top Boxes
- VOIP Phones

### Typical Application

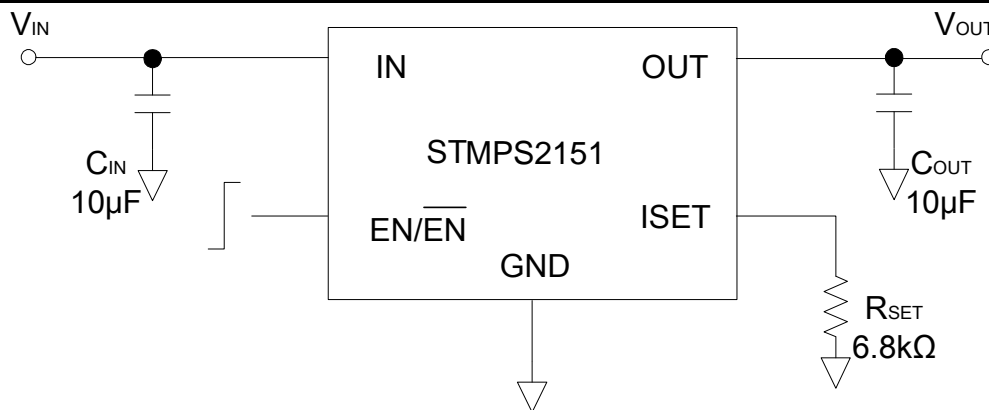

### Ordering Information

Order Part Number	Top Marking	Enable		T <sub>A</sub>	Package	
STMPS2151STR	YW2A	Active High	Green	-40 to +85°C	SOT23-5	Tape & Reel, 3000
STMPS2151ST	YW2B	Active Low	Green	-40 to +85°C	SOT23-5	Tape & Reel, 3000

## Pin Assignments

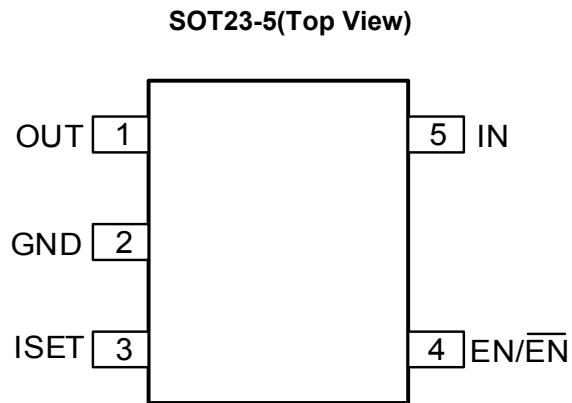

**Figure 1 Pin Assignment**

## Pin Description

Pin Name	Pin number	Pin Description
OUT	1	Output pin, decoupled with a 10 $\mu$ F capacitor to GND
GND	2	Ground pin
ISET	3	External resistor used to set current limit threshold
EN/ $\overline{\text{EN}}$	4	ON/OFF control. Do not leave it floating
IN	5	Input pin, decoupled with a 10 $\mu$ F capacitor to GND

## Absolute Maximum Ratings

Parameter		Rating	Unit
All pins		-0.3 to 6	V
Power Dissipation ( $P_D$ @ $T_A = 25^\circ\text{C}$ , SOT23-5)		0.6	W
Package Thermal Resistance	$\theta_{JA}$ , SOT23-5	250	$^\circ\text{C/W}$
	$\theta_{JC}$ , SOT23-5	130	
Junction Temperature Range		150	$^\circ\text{C}$
Lead Temperature (Soldering, 10 sec.)		260	$^\circ\text{C}$
Storage Temperature Range ( $T_{STG}$ )		-65 to 150	$^\circ\text{C}$
ESD Susceptibility	HBM (Human Body Mode)	6	kV
	CDM (Charged Device Mode)	2	

Note: Input and output negative ratings may be exceeded if input and output diode current ratings are observed.

## Recommended Operating Conditions

Parameter	Rating	Unit
IN	2.7 to 5.5	V
All other pins	0 to 5.5	V
Junction Temperature Range	-40 to 125	$^\circ\text{C}$
Ambient Temperature Range	-40 to 85	$^\circ\text{C}$

## Electrical Characteristics

$T_A=25\text{ }^\circ\text{C}$   $V_{IN} = 5\text{V}$ , unless otherwise noted.

Symbol	Parameter	Conditions	Min.	Typ.	Max.	Unit
$V_{IN}$	Input Voltage Range		2.7		5.5	V
$I_{SHDN}$	Shut down Input Current	Open load, IC Disabled		0.2	1	$\mu\text{A}$
$I_Q$	Quiescent Supply Current	Open load, IC Disabled		60		$\mu\text{A}$
$R_{DS(ON)}$	FET $R_{ON}$			70		m $\Omega$
$V_{EN(H)}$	EN Rising Threshold		2			V
$V_{EN(L)}$	EN Falling Threshold				0.8	V
$I_{EN}$	EN Leakage Current	$V_{EN}=5.0\text{V}$			1	$\mu\text{A}$
$V_{IN\_UVLO}$	IN UVLO Threshold				2.5	V
$V_{IN\_HYS}$	IN UVLO Hysteresis			0.25		V
$I_{LIM}$	Over Current Limit	$R_{SET}=6.8\text{k}\Omega$	0.9	1	1.2	A
$I_{LIM(min)}$				0.4		
$I_{LIM(max)}$				2.5		
$T_{ON}$	Turn-on Time	$R_L=10\Omega$ , $C_{OUT}=1\mu\text{F}$		700		$\mu\text{s}$
$T_{OFF}$	Turn-off Time	$R_L=10\Omega$ , $C_{OUT}=1\mu\text{F}$		20		$\mu\text{s}$
$T_{SD}$	Thermal Shut down Temperature			140		$^\circ\text{C}$
	Thermal Shut down Hysteresis			20		$^\circ\text{C}$

## Block Diagram

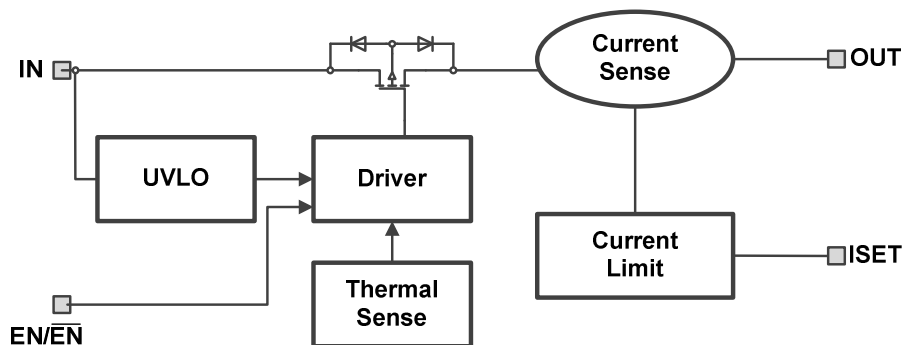

## Application Information

### Power Supply Considerations

A 10µF ceramic capacitor from  $V_{IN}$  to GND to prevent the input voltage from dropping during the hot-plug condition is strongly recommended. However higher capacitance could help reduce the voltage drop. Furthermore, bypassing the output with a 10µF ceramic capacitor improves the immunity of the device to short-circuit transients, because an output short will cause ringing on the input without the input capacitor. It could destroy the internal circuitry when the input transient voltage exceeds the absolute maximum supply voltage even for a short duration.

### Enable

The logic enable controls the power switch, the bias for the charge pump, driver, and other circuitry to reduce the supply current. The supply current is reduced to less than 1µA when a logic low is present on EN pin. A logic high input on EN restores bias to the drive and control circuits and turns the power on. The enable input is compatible with both TTL and CMOS logic levels.

### Current Limiting Setting

Current limit is programmable to protect the power source from over current and short circuit conditions. Connecting a resistor  $R_{SET}$  from  $I_{SET}$  pin to GND to control the current limit:

$$I_{LIM} (A) = 6800/R_{SET} (\Omega).$$

Current limit beyond 2.5A is not recommended.

### Over-Current Protection

The 2151STR responds to over current conditions by limiting output current to the  $I_{LIM}$  levels. When an over current condition is detected, the device maintains a constant output current and reduces the output voltage accordingly. Complete shut down occurs only if the fault is present long enough to activate thermal limit.

Two possible overload conditions can occur. In the first condition, an excessive load occurs while the device is enabled. When the excessive load occurs, very high currents may flow for a short time before the current limit circuit can react. After the current limit circuit has tripped (reached the over current trip threshold) the device switches into constant current mode to limit the current close to  $I_{LIM}$ .

In the second condition, the load is gradually increasing beyond the recommended operating current. The current is permitted to rise until the current limit threshold ( $I_{LIM}$ ) is reached or until the thermal limit of the device is exceeded. The 2151STR is capable of delivering current up to the current limit threshold ( $I_{LIM}$ ) without damaging the device. Once the threshold has been reached, the device switches into its constant current mode.

### **Thermal Protection**

Thermal protection prevents damage to the IC when heavy overload or short circuit conditions are present for extended periods of time. The conditions force the 2151STR into constant current mode, and under shortcircuit conditions, the voltage across the switch is equal to the input voltage. The increased dissipation causes the junction temperature to rise to high levels. The protection circuit senses the junction temperature of the switch and shuts it off. Hysteresis is built into the thermal sense circuit, and after the device has cooled approximately 20 degrees, the switch turns back on. The switch continues to cycle in this way until the overload or input power is removed.

# Typical Performance Characteristics

$T_A=25^\circ\text{C}$ ,  $V_{IN}=5\text{V}$ ,  $C_{IN}=C_{OUT}=10\mu\text{F}$ , unless otherwise noted.

**$I_Q$  vs.  $V_{IN}$**

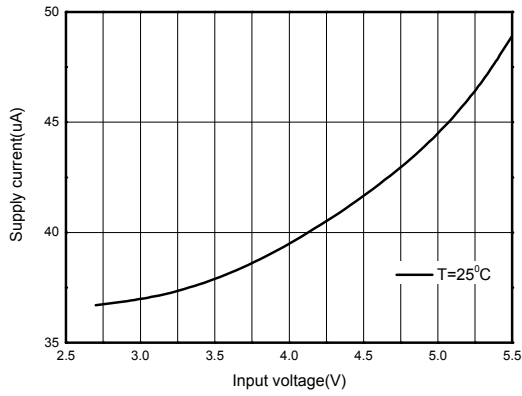

**$I_Q$  vs. Temperature**

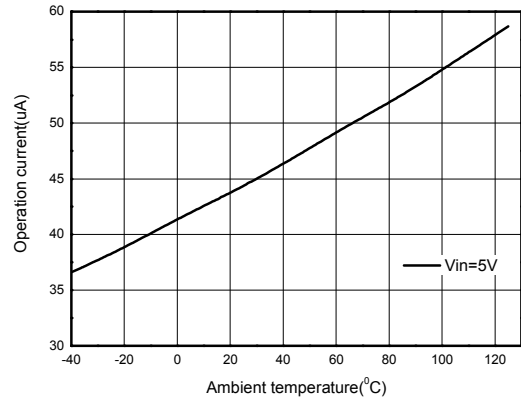

**$I_{SHDN}$  vs.  $V_{IN}$**

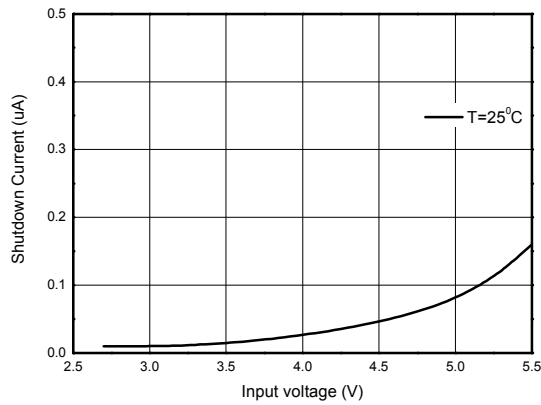

**$V_{EN}$  vs.  $V_{IN}$**

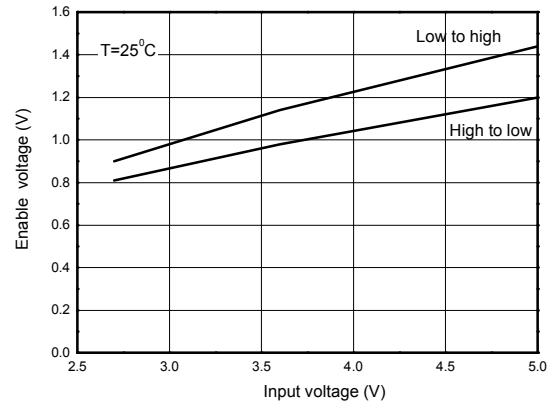

**$R_{DS(ON)}$  vs.  $V_{IN}$**

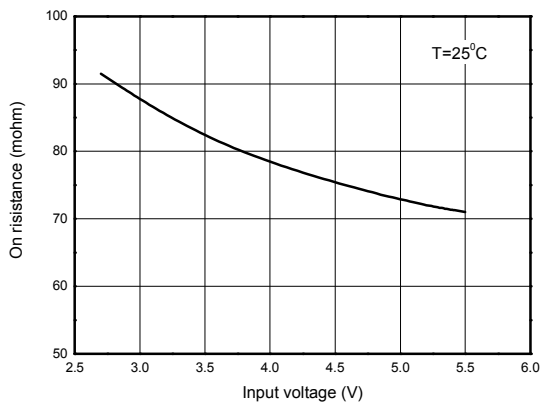

**$R_{DS(ON)}$  vs. Temperature**

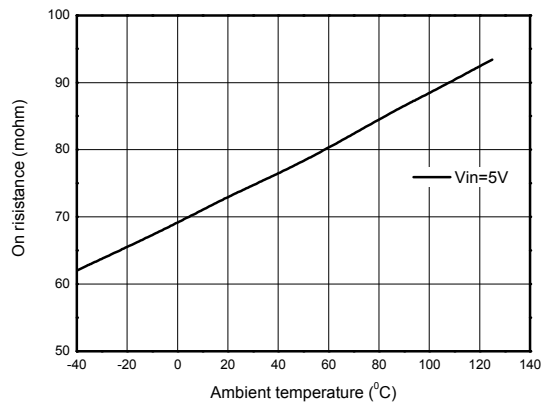

$I_{LIM}$  vs.  $V_{IN}$

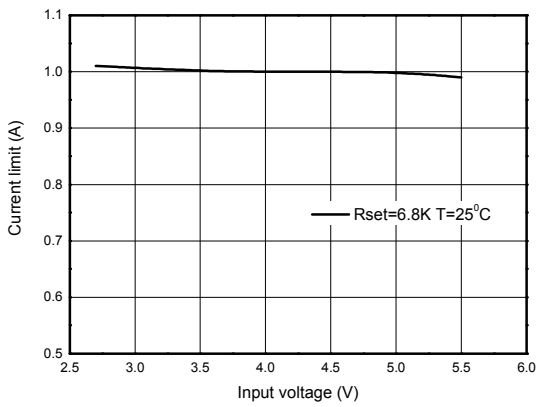

$I_{LIM}$  vs. Temperature

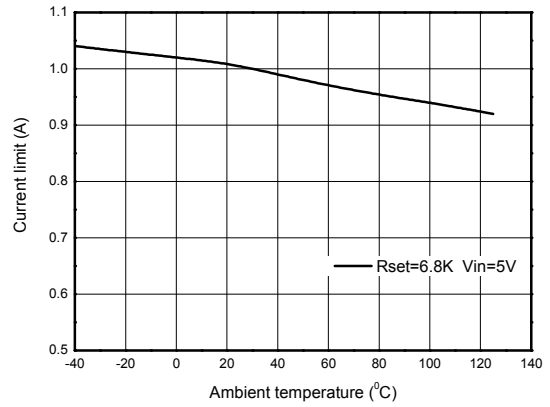

$V_{IN}$  Start up ( $R_{OUT}=2.5\Omega$ )

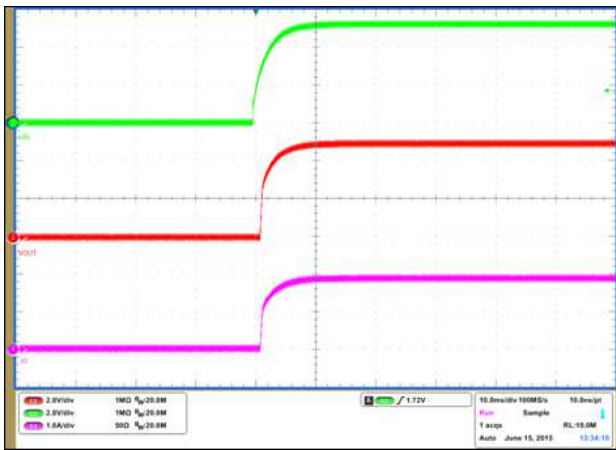

$V_{IN}$  Shut down ( $R_{OUT}=2.5\Omega$ )

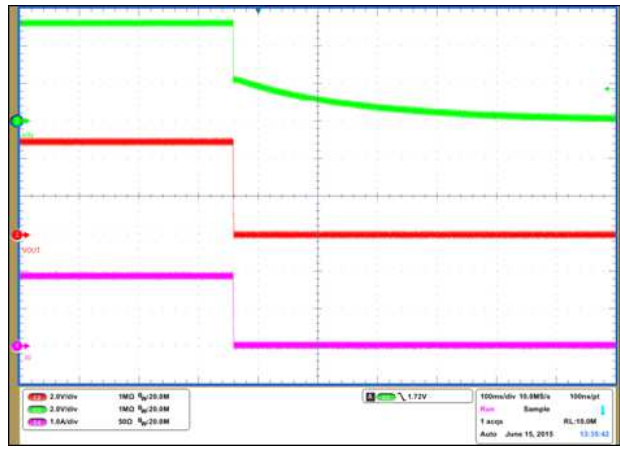

EN Start up ( $R_{OUT}=2.5\Omega$ )

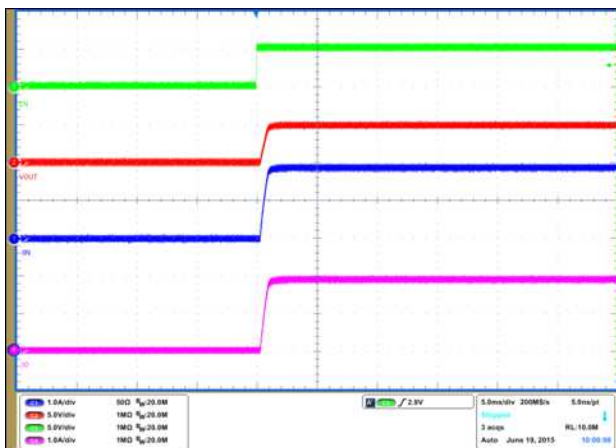

EN Shut down ( $R_{OUT}=2.5\Omega$ )

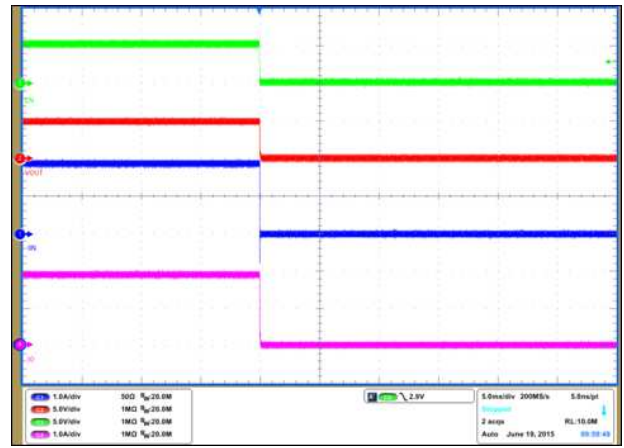

**Over Temperature Protection**  
( $R_{OUT}=10\Omega$ )

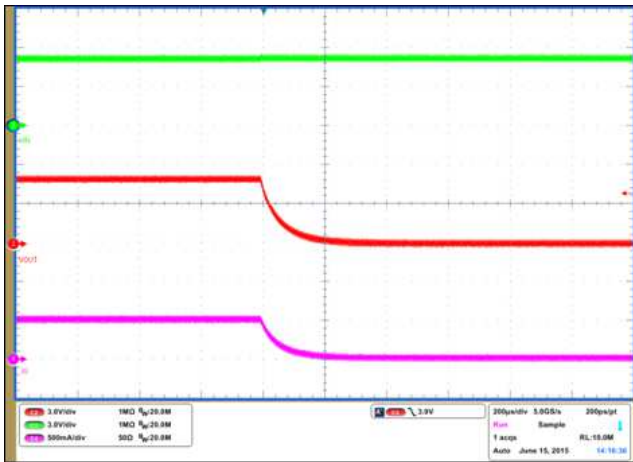

**Over Temperature Recovery**  
( $R_{OUT}=10\Omega$ )

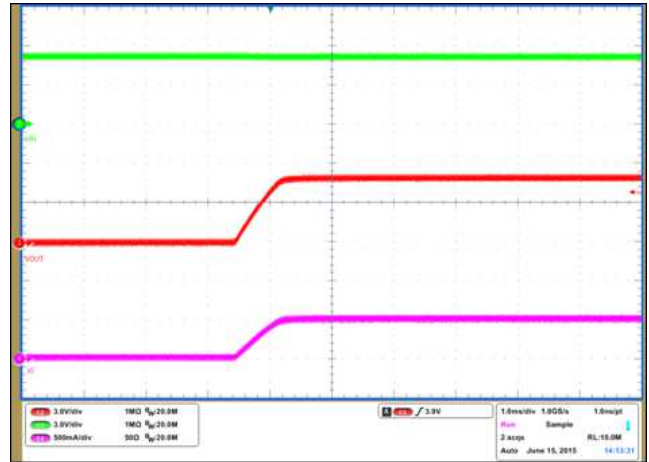

**Over Current Protection**  
( $R_{OUT}=2.5\Omega$ )

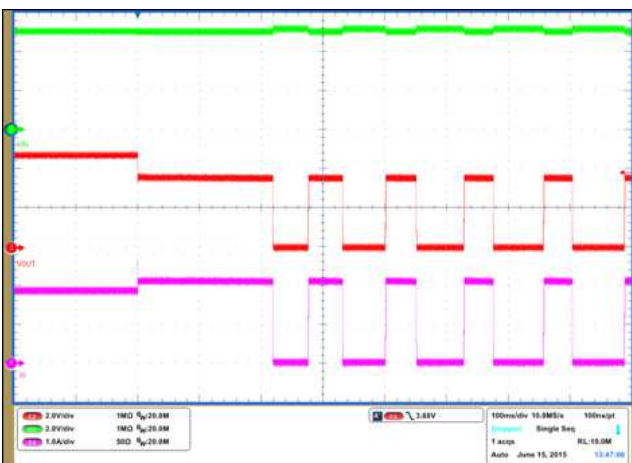

**Over Current Recovery**  
( $R_{OUT}=2.5\Omega$ )

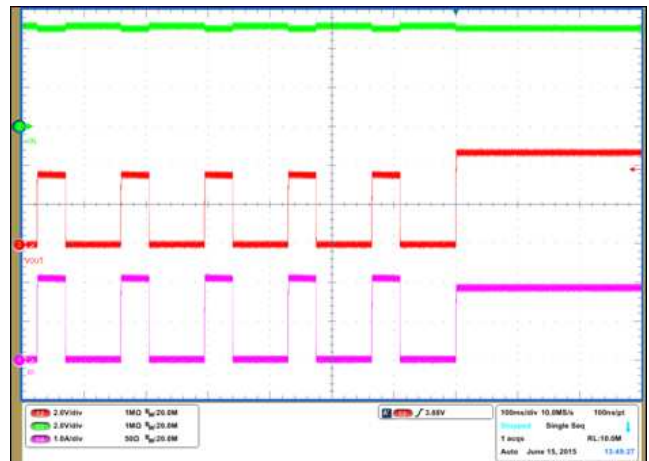

**Short Circuit**  
( $R_{OUT}=10\Omega$ )

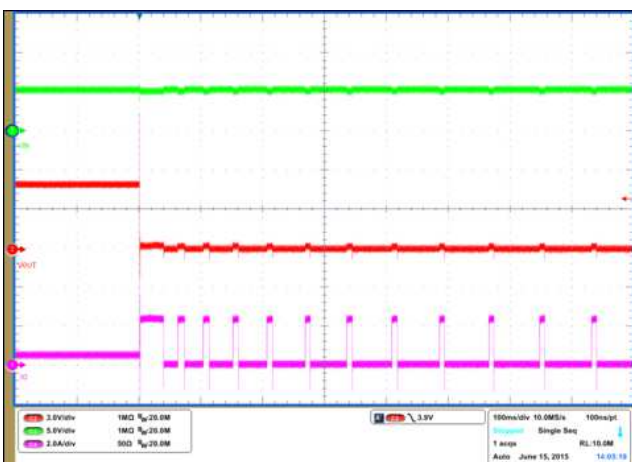

**Short Circuit Recovery**  
( $R_{OUT}=10\Omega$ )

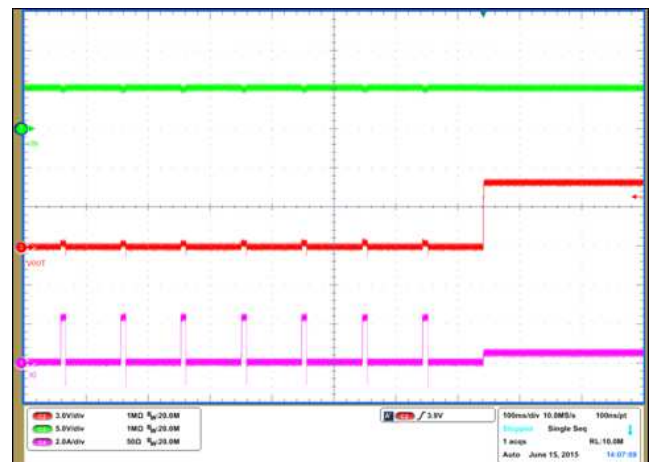

$V_{IN\_UVLO\_H} (R_{OUT}=10\Omega)$

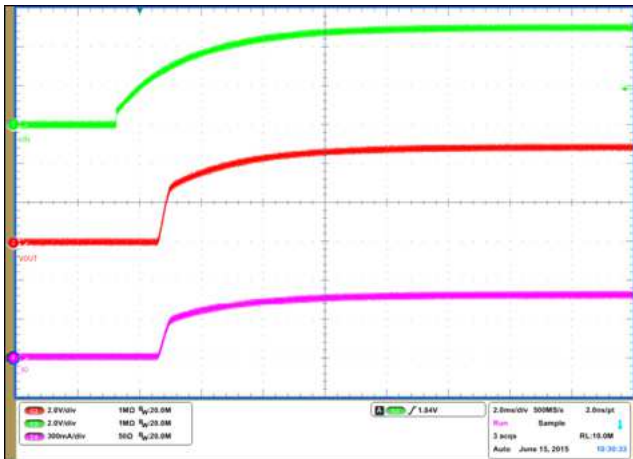

$V_{IN\_UVLO\_L} (R_{OUT}=10\Omega)$

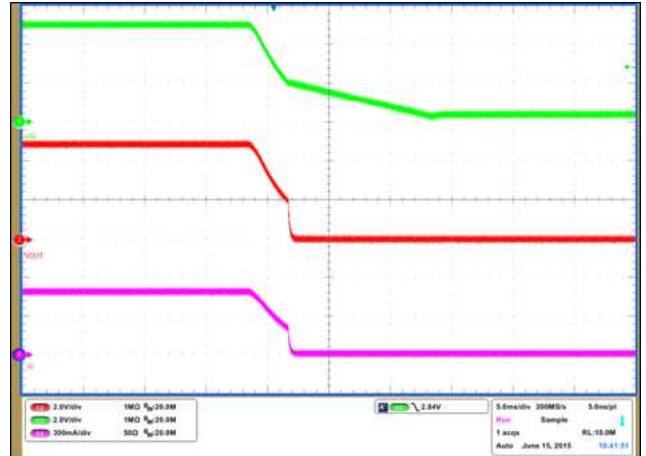

Turn on Time  
( $R_{OUT}=10\Omega, C_{OUT}=1\mu F$ )

Turn off Time  
( $R_{OUT}=10\Omega, C_{OUT}=1\mu F$ )

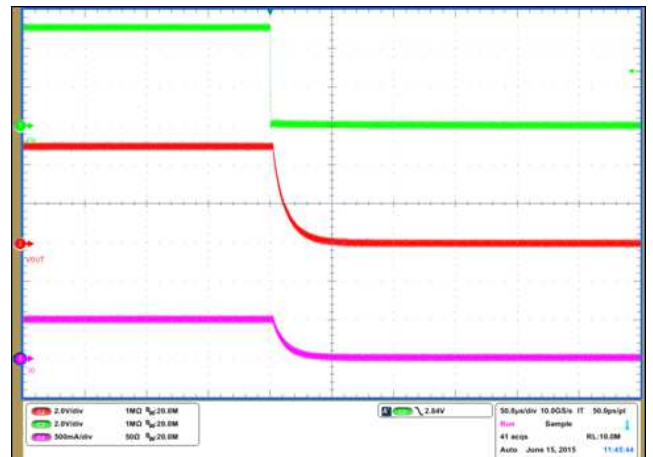
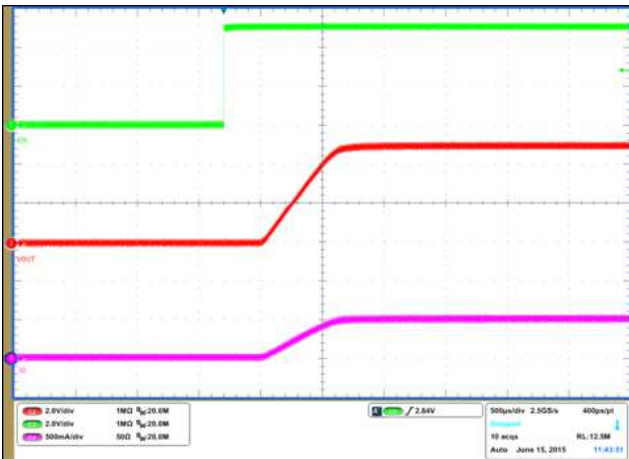

## Physical Dimensions: SOT23-5

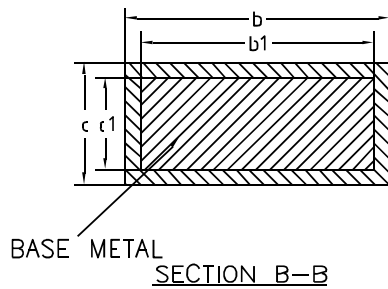
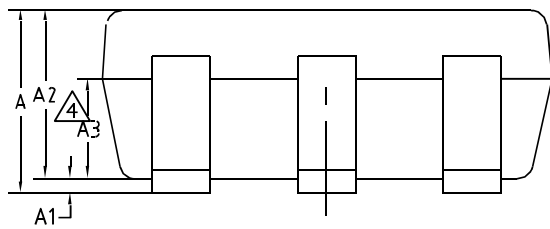
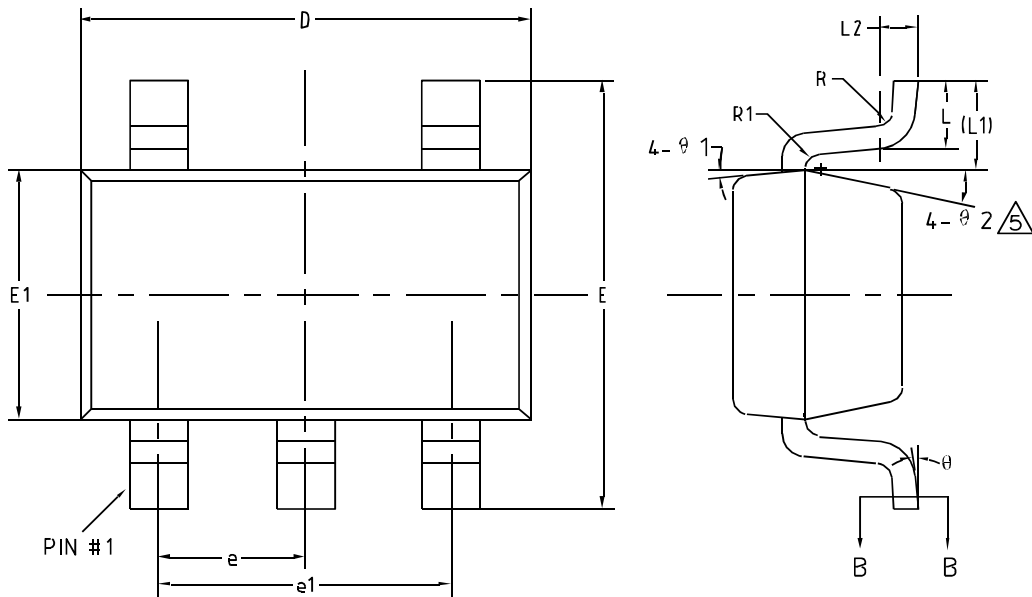

COMMON DIMENSIONS (UNITS OF MEASURE=MILLIMETER)			
Symbol	MIN	NOM	MAX
A	-	-	1.25
A1	0	-	0.15
A2	1.00	1.10	1.20
A3	0.60	0.65	0.70
b	0.36	-	0.50
b1	0.36	0.38	0.45
c	0.14	-	0.20
c1	0.14	0.15	0.16
D	2.826	2.926	3.026
E	2.60	2.80	3.00
E1	1.526	1.626	1.726
e	0.90	0.95	1.00
e1	1.80	1.90	2.00
L	0.35	0.45	0.60
L1	0.59REF		
L2	0.25BSC		
R	0.10	-	-
R1	0.10	-	0.20
$\Theta$	0°	-	8°
$\Theta 1$	3°	5°	7°
$\Theta 2$	6°	-	14°