

SPT 5/ 2-V-7,5-ZB RD - PCB terminal block



1764930

<https://www.phoenixcontact.com/us/products/1764930>

Please be informed that the data shown in this PDF document is generated from our online catalog. Please find the complete data in the user documentation. Our general terms of use for downloads are valid.

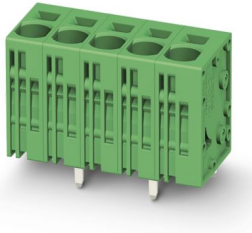

Printed circuit board terminal, nominal current: 41 A, rated voltage (III/2): 1000 V, nominal cross section: 6 mm², number of rows: 1, number of positions per row: 2, product range: SPT 5/..-V, pitch: 7.5 mm, connection method: Push-in spring connection, mounting: Wave soldering, conductor/PCB connection direction: 90 °, color: red, Pin layout: Zigzag pinning W, Solder pin [P]: 4.6 mm, number of solder pins per potential: 1, type of packaging: packed in cardboard

Your advantages

- Time saving push-in connection, tools not required
- Defined contact force ensures that contact remains stable over the long term
- Clamping space opened by means of fixed screwdriver enables convenient conductor connection
- Unrestricted 600-V-UL approval thanks to compact zig-zag pinning
- Vertical connection enables multi-row arrangement on the PCB

Commercial data

Item number	1764930
Packing unit	50 pc
Minimum order quantity	1 pc
Product key	AANBBB
GTIN	4046356418607
Weight per piece (including packing)	8.022 g
Weight per piece (excluding packing)	7.416 g
Country of origin	DE

SPT 5/ 2-V-7,5-ZB RD - PCB terminal block



1764930

<https://www.phoenixcontact.com/us/products/1764930>

Technical data

Product properties

Product type	Printed circuit board terminal
Product family	SPT 5/..-V
Product line	COMBICON Terminals L
Number of positions	2
Pitch	7.5 mm
Number of rows	1
Pin layout	Zigzag pinning W
Solder pins per potential	1

Electrical properties

Properties

Nominal current I_N	41 A
Nominal voltage U_N	1000 V
Rated voltage (III/3)	800 V
Rated surge voltage (III/3)	8 kV
Rated voltage (III/2)	1000 V
Rated surge voltage (III/2)	8 kV
Rated voltage (II/2)	1000 V
Rated surge voltage (II/2)	6 kV

Connection data

Connection technology

Nominal cross section	6 mm ²
-----------------------	-------------------

Conductor connection

Connection method	Push-in spring connection
Conductor cross-section rigid	0.2 mm ² ... 10 mm ² (Conductor connection with open terminal point) 0.75 mm ² ... 10 mm ² (Push-in connection)
Conductor cross-section flexible	0.2 mm ² ... 6 mm ²
Conductor cross-section AWG	24 ... 8
Conductor cross-section flexible, with ferrule without plastic sleeve	0.25 mm ² ... 6 mm ²
Conductor cross-section, flexible, with ferrule, with plastic sleeve	0.25 mm ² ... 6 mm ²
2 conductors with the same cross section, flexible, with TWIN ferrule with plastic sleeve	0.25 mm ² ... 1.5 mm ²
Stripping length	15 mm

Mounting

Mounting type	Wave soldering
Pin layout	Zigzag pinning W

SPT 5/ 2-V-7,5-ZB RD - PCB terminal block



1764930

<https://www.phoenixcontact.com/us/products/1764930>

Material specifications

Material data - contact

Note	WEEE/RoHS-compliant, free of whiskers according to IEC 60068-2-82/JEDEC JESD 201
Contact material	Cu alloy
Surface characteristics	Tin-plated
Metal surface terminal point (top layer)	Tin (4 - 8 µm Sn)
Metal surface soldering area (top layer)	Tin (4 - 8 µm Sn)

Material data - housing

Color (Housing)	red (3001)
Insulating material	PA
Insulating material group	I
CTI according to IEC 60112	600
Flammability rating according to UL 94	V0
Glow wire flammability index GWFI according to EN 60695-2-12	850
Glow wire ignition temperature GWIT according to EN 60695-2-13	775
Temperature for the ball pressure test according to EN 60695-10-2	125 °C

Dimensions

Dimensional drawing	
Pitch	7.5 mm
Width [w]	16.8 mm
Height [h]	28.75 mm
Length [l]	18.5 mm
Installed height	24.15 mm
Solder pin length [P]	4.6 mm
Pin dimensions	1.7 x 0.8 mm

PCB design

Pin spacing	14 mm
Hole diameter	2.1 mm

Mechanical tests

Test for conductor damage and slackening

Specification	IEC 60999-1:1999-11
Result	Test passed

SPT 5/ 2-V-7,5-ZB RD - PCB terminal block



1764930

<https://www.phoenixcontact.com/us/products/1764930>

Pull-out test

Specification	IEC 60999-1:1999-11
Conductor cross-section/conductor type/tractive force setpoint/actual value	0.2 mm ² / solid / > 10 N
	0.2 mm ² / flexible / > 10 N
	10 mm ² / solid / > 90 N
	6 mm ² / flexible / > 80 N
	0.75 mm ² / solid / > 30 N

Electrical tests

Temperature-rise test

Specification	IEC 60947-7-4:2019-01
Requirement temperature-rise test	The sum of ambient temperature and temperature rise of the PCB terminal block shall not exceed the upper limiting temperature.

Short-time withstand current

Specification	IEC 60947-7-4:2019-01
---------------	-----------------------

Insulation resistance

Specification	IEC 60512-3-1:2002-02
Insulation resistance, neighboring positions	> 5 MΩ

Air clearances and creepage distances |

Specification	IEC 60947-7-4:2019-01
Insulating material group	I
Comparative tracking index (IEC 60112)	CTI 600
Rated insulation voltage (III/3)	800 V
Rated surge voltage (III/3)	8 kV
minimum clearance value - non-homogenous field (III/3)	8 mm
minimum creepage distance (III/3)	10 mm
Rated insulation voltage (III/2)	1000 V
Rated surge voltage (III/2)	8 kV
minimum clearance value - non-homogenous field (III/2)	8 mm
minimum creepage distance (III/2)	8 mm
Rated insulation voltage (II/2)	1000 V
Rated surge voltage (II/2)	6 kV
minimum clearance value - non-homogenous field (II/2)	5.5 mm
minimum creepage distance (II/2)	5.5 mm

Environmental and real-life conditions

Vibration test

Specification	IEC 60068-2-6:1995-03
Frequency	10 - 150 - 10 Hz
Sweep speed	1 octave/min
Amplitude	0.35 mm (10 Hz ... 60.1 Hz)

SPT 5/ 2-V-7,5-ZB RD - PCB terminal block



1764930

<https://www.phoenixcontact.com/us/products/1764930>

Acceleration	5g (60.1 Hz ... 150 Hz)
Test duration per axis	2.5 h
Test directions	X-, Y- and Z-axis

Glow-wire test

Specification	IEC 60695-2-10:2013-04
Temperature	850 °C
Time of exposure	5 s

Aging

Specification	IEC 60947-7-4:2019-01
---------------	-----------------------

Ambient conditions

Ambient temperature (operation)	-40 °C ... 105 °C (Depending on the current carrying capacity/derating curve)
Ambient temperature (storage/transport)	-40 °C ... 70 °C
Relative humidity (storage/transport)	30 % ... 70 %
Ambient temperature (assembly)	-5 °C ... 100 °C

Packaging specifications

Type of packaging	packed in cardboard
-------------------	---------------------

SPT 5/ 2-V-7,5-ZB RD - PCB terminal block



1764930

<https://www.phoenixcontact.com/us/products/1764930>

Drawings

Dimensional drawing

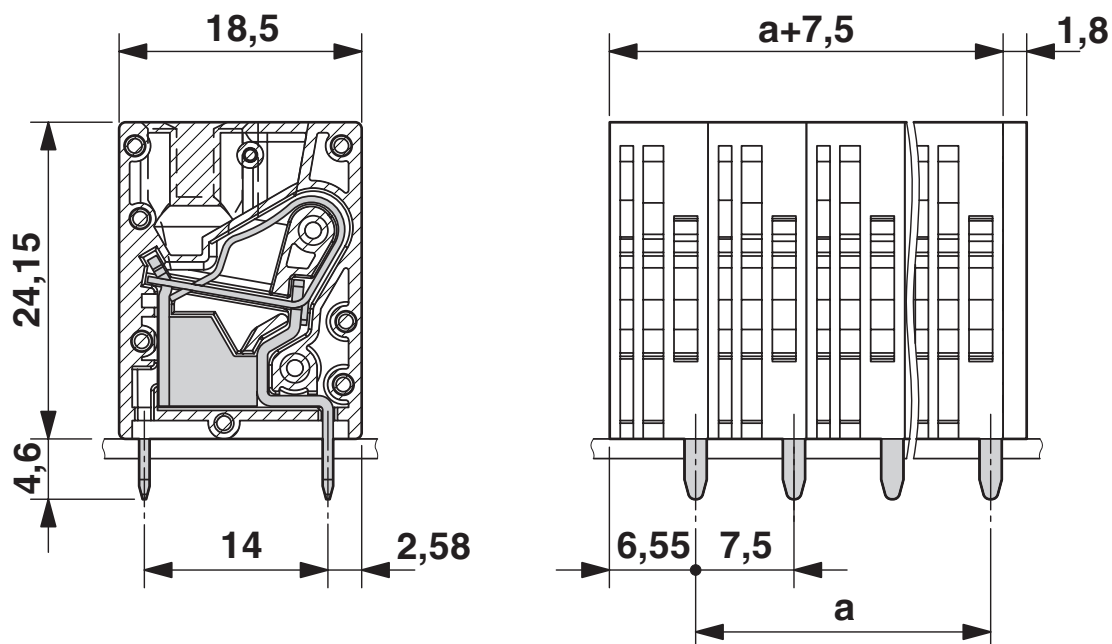

Diagram

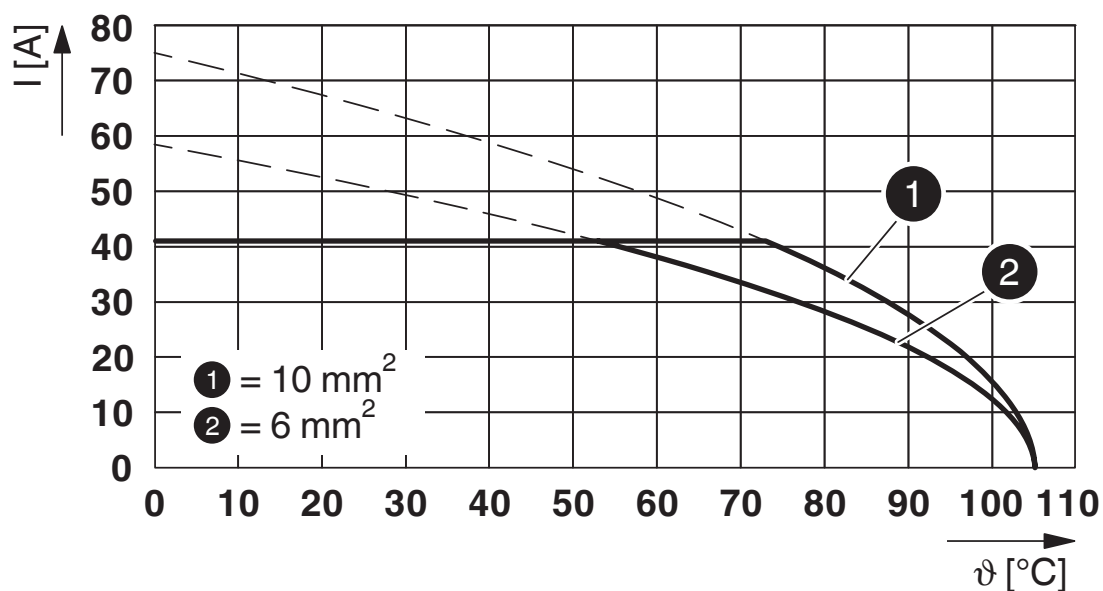

Type: SPT 5/...-V-7,5-ZB

SPT 5/ 2-V-7,5-ZB RD - PCB terminal block



1764930

<https://www.phoenixcontact.com/us/products/1764930>

Drilling plan/solder pad geometry

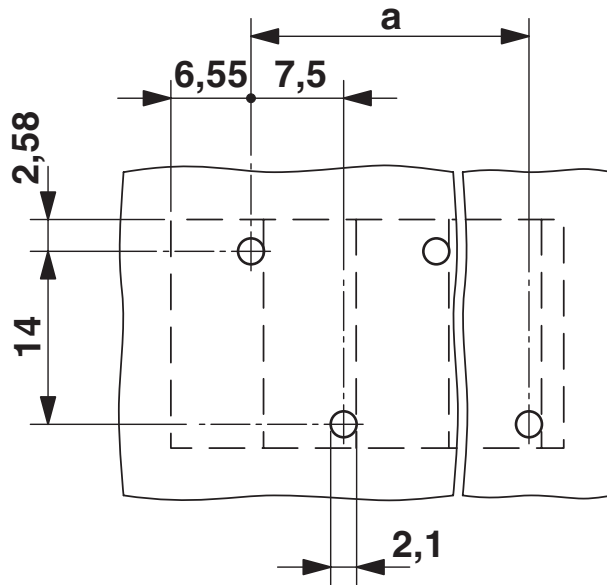

SPT 5/ 2-V-7,5-ZB RD - PCB terminal block



1764930

<https://www.phoenixcontact.com/us/products/1764930>

Approvals

To download certificates, visit the product detail page: <https://www.phoenixcontact.com/us/products/1764930>

 VDE Zeichengenehmigung Approval ID: 40042909				
	Nominal voltage U_N	Nominal current I_N	Cross section AWG	Cross section mm^2
keine				
	1000 V	41 A	-	0.2 - 10

 cULus Recognized Approval ID: E60425-20061129				
	Nominal voltage U_N	Nominal current I_N	Cross section AWG	Cross section mm^2
B				
	600 V	36 A	24 - 8	-
C				
	600 V	36 A	24 - 8	-

SPT 5/ 2-V-7,5-ZB RD - PCB terminal block



1764930

<https://www.phoenixcontact.com/us/products/1764930>

Classifications

ECLASS

ECLASS-13.0	27460101
ECLASS-15.0	27460101

ETIM

ETIM 9.0	EC002643
----------	----------

UNSPSC

UNSPSC 21.0	39121400
-------------	----------

SPT 5/ 2-V-7,5-ZB RD - PCB terminal block



1764930

<https://www.phoenixcontact.com/us/products/1764930>

Environmental product compliance

EU RoHS

Fulfills EU RoHS substance requirements	Yes, No exemptions
---	--------------------

China RoHS

Environment friendly use period (EFUP)	EFUP-E
	No hazardous substances above the limits

EU REACH SVHC

REACH candidate substance (CAS No.)	No substance above 0.1 wt%
-------------------------------------	----------------------------

EF3.0 Climate Change

CO2e kg	0.076 kg CO2e
---------	---------------

Phoenix Contact 2025 © - all rights reserved
<https://www.phoenixcontact.com>

Phoenix Contact USA
586 Fulling Mill Road
Middletown, PA 17057, United States
(+717) 944-1300
info@phoenixcon.com