

Very low offset single bipolar operational amplifier

Features

- Extremely low offset: 150 μ V/ max.
- Low input bias current: 1.8nA
- LOW Vio drift: 0.5 μ V/ $^{\circ}$ C
- Ultra stable with time: 2 μ V/month max.
- Wide supply voltage range: \pm 3V to \pm 16V
- Temperature range: 0 $^{\circ}$ C to 70 $^{\circ}$ C

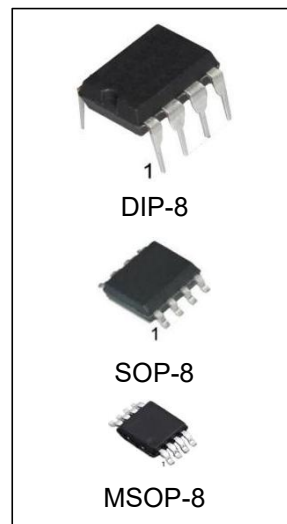

Ordering Information

DEVICE	Package Type	MARKING	Packing	Packing Qty
OP07CPG	DIP-8	OP07C	TUBE	2000/box
OP07DPG	DIP-8	OP07D	TUBE	2000/box
OP07CDRG	SOP-8	OP07C	REEL	2500/reel
OP07DDRG	SOP-8	OP07D	REEL	2500/reel
OP07CDGKRG	MSOP-8	OP07C	REEL	3000/reel
OP07DDGKRG	MSOP-8	OP07D	REEL	3000/reel

Description

The OP07 is a very high precision op-amp with an offset voltage maximum of 150 μ V. Offering also low input current (1.8nA) and high gain (400V/mV), the OP07 is particularly suitable for instrumentation applications.

Pin Configuration

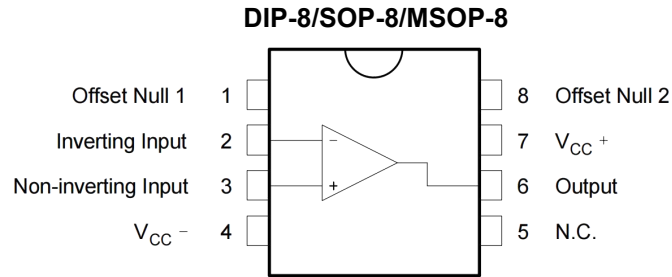

Schematic diagram

Figure 1. Schematic diagram

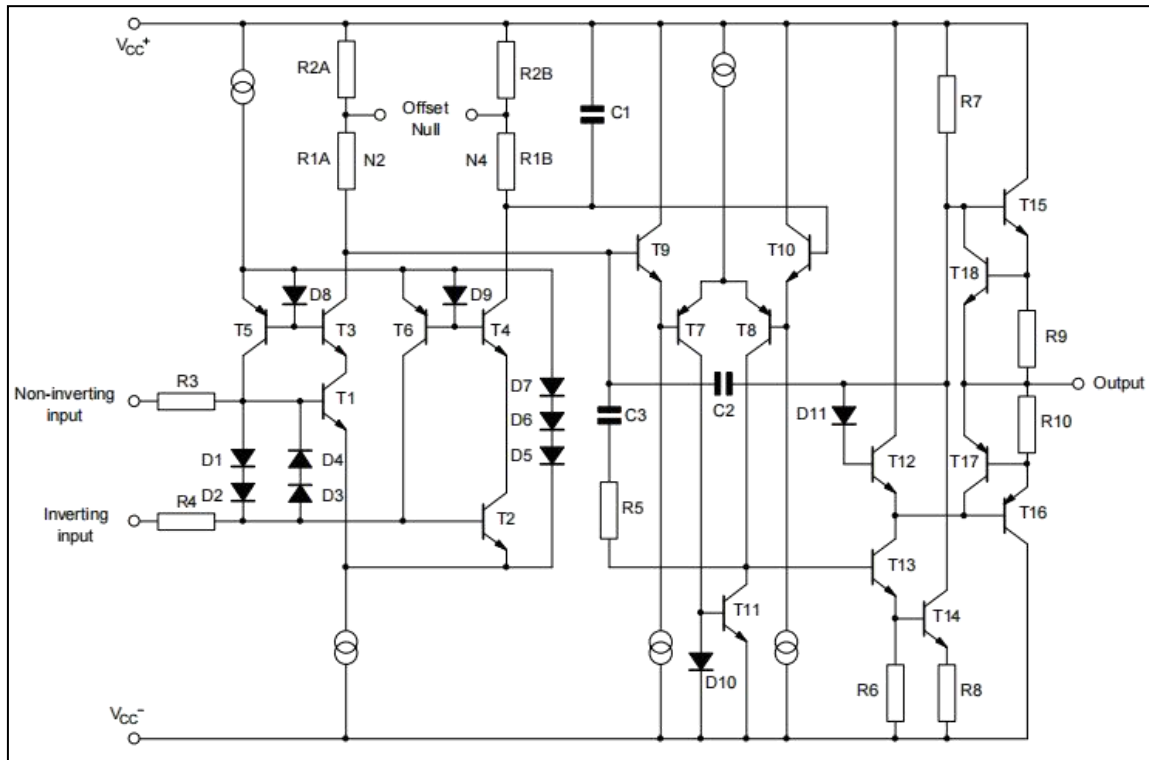
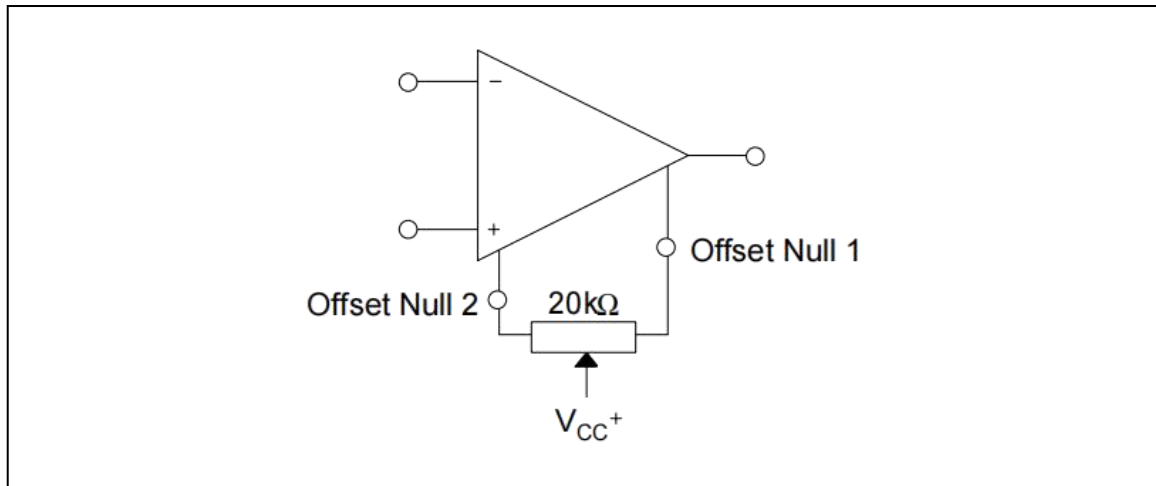

Figure 2. Input offset voltage nulling circuit



Absolute maximum ratings

Table 1. Absolute maximum ratings

Symbol	Parameter	Value	Unit
V_{CC}	Supply voltage	± 16	V
V_{id}	Differential input voltage	± 30	V
V_i	Input voltage	± 16	V
T_{oper}	Operating temperature	0 to 70	$^{\circ}\text{C}$
T_{stg}	Storage temperature	-65 to 150	$^{\circ}\text{C}$
R_{thja}	Thermal resistance junction to ambient DIP8	85	$^{\circ}\text{C}/\text{W}$
R_{thjc}	Thermal resistance junction to case DIP8	41	$^{\circ}\text{C}/\text{W}$
T_L	Lead Temperature (Soldering, 10 seconds)	260	$^{\circ}\text{C}$
ESD	HBM: human body model	1.5	kV
	MM: machine model	200	V
	CDM: charged device model	1.5	kV

Note:

1. Absolute Maximum Ratings indicate limits beyond which damage to the device may occur. Operating Ratings indicate conditions for which the device is intended to be functional, but specific performance is not ensured.
2. Short-circuits can cause excessive heating and destructive dissipation.
3. R_{th} are typical values.
4. Human body model: 100pF discharged through a 1.5k Ω resistor between two pins of the device, done for all couples of pin combinations with other pins floating.
5. Machine model: a 200pF cap is charged to the specified voltage, then discharged directly between two pins of the device with no external series resistor (internal resistor < 5 Ω). Done for all couples of pin combinations with other pins floating.
6. Charged device model: all pins plus package are charged together to the specified voltage and then discharged directly to the ground.

Electrical characteristics

Table 2. VCC = ±15 V, Tamb = 25° C (unless otherwise specified)

Symbol	Parameter	OP07C			OP07D			Unit
		Min.	Typ.	Max.	Min.	Typ.	Max.	
V _{io}	Input offset voltage 0°C ≤ T _{amb} ≤ +70°C		60				150	μV
			85				250	
	Long term input offset - voltage stability (1)		0.4					uV/Mo
DV _{io}	Input offset voltage drift		0.5				2.5	uV/°C
I _{io}	Input offset current (V _{ic} = 0V) 0°C ≤ T _{amb} ≤ +70°C		0.8	6		0.8	6	nA
				7			7	
DI _{io}	Input offset current drift		15	50		15	50	pA/°C
DI _{ib}	Input bias current drift		15	50		15	50	pA/°C
R _o	Open loop output resistance		60			60		Ω
R _{id}	Differential input resistance		33			33		MΩ
R _{ic}	Common mode input resistance		120			120		GΩ
V _{icm}	Input common mode voltage range 0°C ≤ T _{amb} ≤ +70°C	±13	±13.5		±13	±13.5		V
		±13			±13			
CMR	Common-mode rejection ratio (V _{ic} = V _{icm} -min) 0°C ≤ T _{amb} ≤ +70°C	100	120		94	110		dB
		97			94	106		
SVR	Supply voltage rejection ratio (VCC = ±3 to ±16V) 0°C ≤ T _{amb} ≤ +70°C	90	104		90	104		dB
		86			86			
A _{vd}	Large signal voltage gain VCC = ±15, R _L = 2kΩ, V _o = ±10V 0°C ≤ T _{amb} ≤ +105°C VCC = ±3, R _L = 500Ω, V _o = ±0.5V	120	40		120	400		V/mV
		100			100			
		100	400		100	400		
V _{opp}	Output voltage swing R _L = 10kΩ R _L = 2kΩ R _L = 1kΩ 0°C ≤ T _{amb} ≤ +105°C R _L = 2kΩ	±12	±13		±12	±13		V
		±11.5	±12.8		±11.5	±12.8		
			±12			±12		
		±11			±11			
SR	Slew rate (R _L = 2kΩ, C _L = 100pF)		0.17			0.17		V/us
GBP	Gain bandwidth product (R _L = 2kΩ, C _L = 100pF, f = 100kHz)		0.5			0.5		MHz
I _{CC}	Supply current - no load 0°C ≤ T _{amb} ≤ +70°C VCC = ±3V		2.7	5		2.7	5	mA
			0.67	1.3		0.67	1.3	
e _n	Equivalent input noise voltage f = 10Hz f = 100Hz f = 1kHz		11	20		11	20	$\frac{nV}{\sqrt{Hz}}$
			10.5	13.5		10.5	13.5	
			10	11.5		10	11.5	
i _n	Equivalent input noise current f = 10Hz f = 100Hz f = 1kHz		0.3	0.9		0.3	0.9	$\frac{pA}{\sqrt{Hz}}$
			0.2	0.3		0.2	0.3	
			0.1	0.2		0.1	0.2	

1. Long term input offset voltage stability refers to the average trend line of V_{io} vs time over extended periods after the first 30 days of operation.

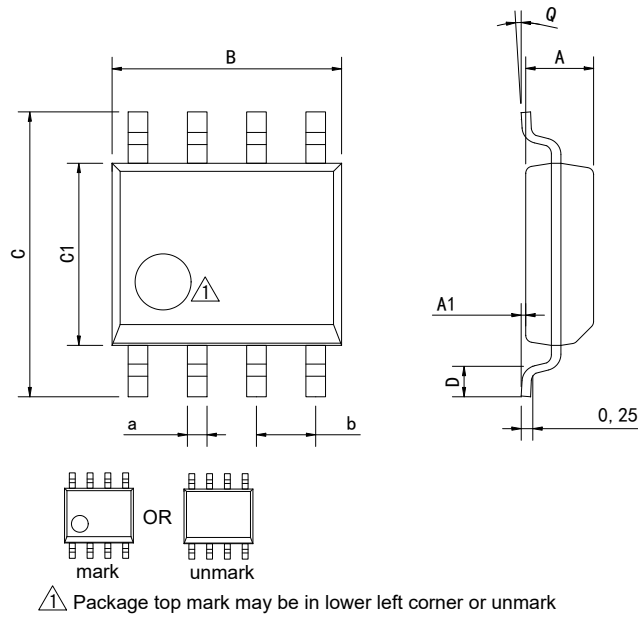
Physical Dimensions
SOP-8

Dimensions In Millimeters(SOP-8)									
Symbol:	A	A1	B	C	C1	D	Q	a	b
Min:	1.35	0.05	4.90	5.80	3.80	0.40	0°	0.35	1.27 BSC
Max:	1.55	0.20	5.10	6.20	4.00	0.80	8°	0.45	

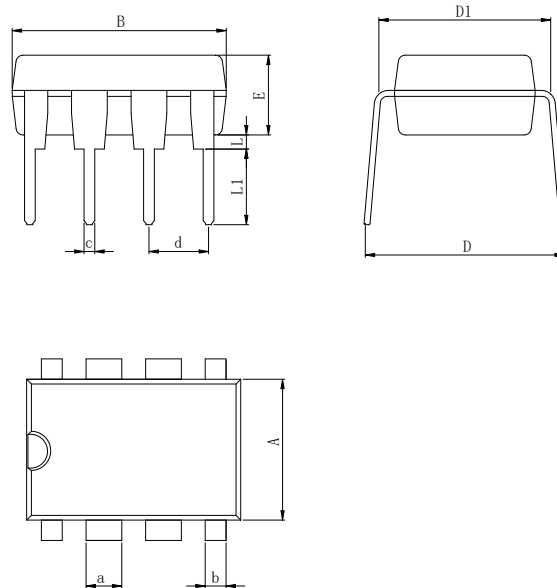
DIP-8

Dimensions In Millimeters(DIP-8)											
Symbol:	A	B	D	D1	E	L	L1	a	b	c	d
Min:	6.10	9.00	8.10	7.42	3.10	0.50	3.00	1.50	0.85	0.40	2.54 BSC
Max:	6.68	9.50	10.9	7.82	3.55	0.70	3.60	1.55	0.90	0.50	

Physical Dimensions

MSOP-8

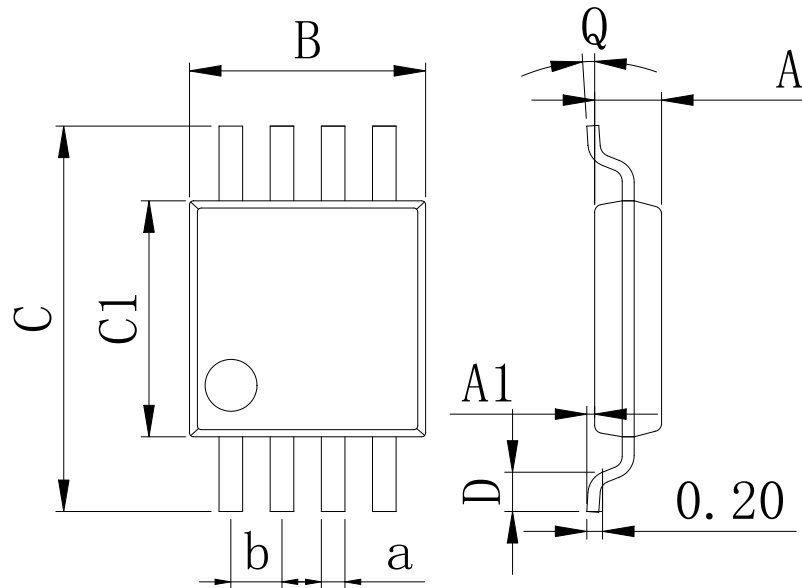
Dimensions In Millimeters(MSOP-8)

Symbol:	A	A1	B	C	C1	D	Q	a	b
Min:	0.80	0.05	2.90	4.75	2.90	0.35	0°	0.25	0.65 BSC
Max:	0.90	0.20	3.10	5.05	3.10	0.75	8°	0.35	

Revision History

REVISION NUMBER	DATE	REVISION	PAGE
V1.0	2019-8	New	1-8
V1.1	2021-9	Update encapsulation type、 Updated DIP-8 dimension	1、 5
V1.2	2024-10	Update Lead Temperature	3
V1.3	2025-12	Update important statements、 Update SOP-8 Dimension drawing	5、 8

IMPORTANT STATEMENT:

hanschip Semiconductor reserves the right to change products and services offered without prior notice. Customers should obtain the latest relevant information before placing orders and verify that such information is current and complete. hanschip Semiconductor assumes no responsibility or liability for altered documents.

Customers are responsible for complying with safety standards and implementing safety measures when using hanschip Semiconductor products in system design and end-product manufacturing. You assume full responsibility for: selecting the appropriate hanschip Semiconductor products for your application; designing, validating, and testing your application; and ensuring that your application complies with applicable standards and all other safety, security, or other requirements. This is to prevent potential risks that may lead to personal injury or property damage.

hanschip Semiconductor products are not approved for use in life support, military, aerospace, or other high-risk applications. hanschip products are neither intended nor warranted for use in such systems or equipment. Any failure or malfunction may lead to personal injury or severe property damage. Such applications are deemed "Unsafe Use." Unsafe Use includes, but is not limited to: surgical and medical equipment, nuclear energy control equipment, aircraft or spacecraft instruments, control or operation of vehicle power, braking, or safety systems, traffic signal instruments, all types of safety devices, and any other applications intended to support or sustain life. hanschip Semiconductor shall not be liable for consequences resulting from Unsafe Use in these fields. Users must independently evaluate and assume all risks. Any issues, liabilities, or losses arising from the use of products beyond their approved applications shall be solely borne by the user. Users may not claim any compensation from hanschip Semiconductor based on these terms. If any third party claims against hanschip Semiconductor due to such Unsafe Use, the user shall compensate hanschip Semiconductor for all resulting damages and liabilities.

hanschip Semiconductor provides technical and reliability data (including datasheets), design resources (including reference designs), application or other design advice, web tools, safety information, and other resources for its semiconductor products. However, no guarantee is made that these resources are free from defects, and no express or implied warranties are provided. The use of testing and other quality control techniques is limited to hanschip Semiconductor's quality assurance scope. Not all parameters of each device are tested.

hanschip Semiconductor's documentation authorizes you to use these resources only for developing applications related to the products described herein. You are not granted rights to any other intellectual property of hanschip Semiconductor or any third party. Any other reproduction or display of these resources is strictly prohibited. You shall fully indemnify hanschip Semiconductor and its agents against any claims, damages, costs, losses, and liabilities arising from your use of these resources. hanschip Semiconductor shall not be held responsible.