

### Features

- Wide supply voltage range from 0.8V to 2.7V
- Inputs accept voltages up to 2.7V
- I<sub>OFF</sub> supports partial-power-down mode
- Low static power consumption; I<sub>CC</sub>=0.5μA (Max.)
- ESD Protection Exceeds JESD 22
  - 2000-V Human-Body Model (A114-A)
  - 200-V Machine Model (A115-A)
  - 1000-V Charged-Device Model (C101)

### Applications

- AV Receiver
- Audio Dock: Portable
- Blu-ray Player and Home Theater
- Embedded PC
- Personal Digital Assistant(PDA)
- Power: Telecom/Server AC/DC Supply: Single Controller: Analog and Digital
- Solid State Drive(SSD): Client and Enterprise
- Wireless Headset, Keyboard, and Mouse

### General Description

The is a single 2-input EXCLUSIVE -OR gate which provides the Function  $Y = A \oplus B$  or  $Y = \bar{A}B + A\bar{B}$  in positive logic.

This device ensures a very low static and dynamic power consumption across the entire VCC range from 0.8V to 2.7V.

### Logic Diagram

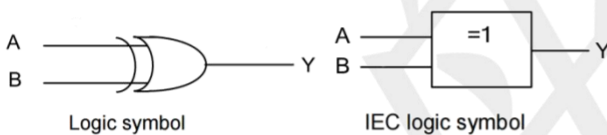

### Pin Configuratio (TOP VIEW)

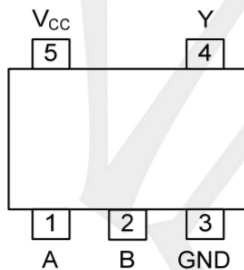

SOT-353

### Function Table (each gate)

INPUT(A)	INPUT(B)	OUTPUT(Y)
L	L	L
L	H	H
H	L	H
H	H	L

Note:H: HIGH voltage level;L: LOW voltage level.

## Absolute Maximum Ratings

PARAMETER	SYMBOL	CONDITIONS	RATINGS	UNIT
Supply Voltage	V <sub>CC</sub>		-0.5 ~ +3.6	V
Input Voltage	V <sub>IN</sub>		-0.5 ~ +3.6	V
Output Voltage	V <sub>OUT</sub>	Output in the high or low state	-0.5 ~ +V <sub>CC</sub> +0.5V	V
		Output in the power-off state	-0.5 ~ +3.6	V
VCC or GND Current	I <sub>CC</sub>		±50	mA
Continuous Output Current	I <sub>OUT</sub>	V <sub>OUT</sub> =0~V <sub>CC</sub>	±20	mA
Input Clamp Current	I <sub>IK</sub>	V <sub>IN</sub> <0	-50	mA
Output Clamp Current	I <sub>OK</sub>	V <sub>OUT</sub> <0	-50	mA
Storage Temperature Range	T <sub>STG</sub>		-65 ~ +150	°C
Junction to Ambient	θ <sub>JA</sub>		280	°C/W

Note: Absolute maximum ratings are those values beyond which the device could be permanently damaged. Absolute maximum ratings are stress ratings only and functional device operation is not implied.

## Recommended Operating Conditions

PARAMETER	SYMBOL	TEST CONDITIONS	MIN	TYP	MAX	UNIT
Supply Voltage	V <sub>CC</sub>	Operating	0.8	--	2.7	V
Input Voltage	V <sub>IN</sub>		0	--	3.6	V
Output Voltage	V <sub>OUT</sub>	High or low state	0	--	V <sub>CC</sub>	V
Input Transition Rise or Fall Rate	Δt/Δv	V <sub>CC</sub> =0.8V ~ 2.7V	--	--	200	ns/V
Operating Temperature	T <sub>A</sub>		-40	--	+125	°C

### Electrical Characteristics (T<sub>A</sub>=25°C ,unless otherwise specified)

PARAMETER	SYMBOL	TEST CONDITIONS	MIN	TYP	MAX	UNIT	
High-level Input Voltage	V <sub>IH</sub>	V <sub>CC</sub> =0.8V	V <sub>CC</sub>	--	--	V	
		V <sub>CC</sub> =1.1V ~ 1.95V	0.65×V <sub>CC</sub>	--	--	V	
		V <sub>CC</sub> =2.3V ~ 2.7V	1.6	--	--	V	
Low-level Input Voltage	V <sub>IL</sub>	V <sub>CC</sub> =0.8V	--	--	0	V	
		V <sub>CC</sub> =1.1V ~ 1.95V	--	--	0.35×V <sub>CC</sub>	V	
		V <sub>CC</sub> =2.3V ~ 2.7V	--	--	0.7	V	
High-Level Output voltage	V <sub>OH</sub>	V <sub>CC</sub> =0.8 ~ 3.6V, I <sub>OH</sub> =-20μA	V <sub>CC</sub> -0.1	--	--	V	
		V <sub>CC</sub> =1.1V, I <sub>OH</sub> =-1.1mA	0.75×V <sub>CC</sub>	--	--	V	
		V <sub>CC</sub> =1.4V, I <sub>OH</sub> =-1.7mA	1.11	--	--	V	
		V <sub>CC</sub> =1.65V, I <sub>OH</sub> =-1.9mA	1.32	--	--	V	
		V <sub>CC</sub> =2.3V	I <sub>OH</sub> =-2.3mA	2.05	--	--	V
			I <sub>OH</sub> =-3.1mA	1.9	--	--	V
		V <sub>CC</sub> =2.7V	I <sub>OH</sub> =-2.7mA	2.72	--	--	V
I <sub>OH</sub> =-4mA	2.6		--	--	V		
Low-Level Output voltage	V <sub>OL</sub>	V <sub>CC</sub> =0.8 ~ 2.7V, I <sub>OL</sub> =20μA	--	--	0.1	V	
		V <sub>CC</sub> =1.1V, I <sub>OL</sub> =1.1mA	--	--	0.3×V <sub>CC</sub>	V	
		V <sub>CC</sub> =1.4V, I <sub>OL</sub> =1.7mA	--	--	0.31	V	
		V <sub>CC</sub> =1.65V, I <sub>OL</sub> =1.9mA	--	--	0.31	V	
		V <sub>CC</sub> =2.3V	I <sub>OL</sub> =2.3mA	--	--	0.31	V
			I <sub>OL</sub> =3.1mA	--	--	0.44	V
		V <sub>CC</sub> =2.7V	I <sub>OL</sub> =2.7mA	--	--	0.31	V
I <sub>OL</sub> =4mA	--		--	0.44	V		
Input Leakage Current	I <sub>I(LEAK)</sub>	V <sub>CC</sub> =0 ~ 2.7V, V <sub>IN</sub> =GND ~ 2.7V	--	--	±0.1	μA	
Power OFF Leakage Current	I <sub>OFF</sub>	V <sub>CC</sub> =0 V, V <sub>IN</sub> or V <sub>OUT</sub> =0 ~ 2.7V	--	--	±0.2	μA	
Additional Power OFF Leakage Current	ΔI <sub>OFF</sub>	V <sub>CC</sub> =0 V~0.2V, V <sub>IN</sub> or V <sub>OUT</sub> =0 ~ 2.7V	--	--	±0.2	μA	
Quiescent Supply Current	I <sub>CC</sub>	V <sub>CC</sub> =0.8 ~2.7V, V <sub>IN</sub> =V <sub>CC</sub> or GND, I <sub>OUT</sub> =0	--	--	0.5	μA	
Additional Quiescent Supply Current	ΔI <sub>CC</sub>	V <sub>CC</sub> =2.7 V, V <sub>IN</sub> =V <sub>CC</sub> -0.6V, I <sub>OUT</sub> =0	--	--	40	μA	
Input Capacitance	C <sub>I</sub>	V <sub>CC</sub> =0V-2.7V, V <sub>IN</sub> =V <sub>CC</sub> or GND	--	1.5	--	pF	
Output Capacitance	C <sub>OUT</sub>	V <sub>CC</sub> =0V, V <sub>OUT</sub> =GND	--	3	--	pF	

**OPERATING CHARACTERISTICS** (f=10MHz, TA =25°C , unless otherwise specified)

PARAMETER	SYMBOL	TEST CONDITIONS	MIN	TYP	MAX	UNIT
Power Dissipation Capacitance	C <sub>PD</sub>	V <sub>CC</sub> =0.8V	--	2.7	--	pF
		V <sub>CC</sub> =1.2±0.1V	--	2.9	--	pF
		V <sub>CC</sub> =1.5±0.1V	--	3.0	--	pF
		V <sub>CC</sub> =1.8±0.15V	--	3.1	--	pF
		V <sub>CC</sub> =2.5±0.2V	--	3.6	--	pF
		V <sub>CC</sub> =2.7±0.3V	--	4.2	--	pF

**SWITCHING CHARACTERISTICS** ( TA =25°C, unless otherwise specified)

PARAMETER	SYMBOL	TEST CONDITIONS	MIN	TYP	MAX	UNIT	
Propagation delay from inputs (A or B) to output(Y)	t <sub>PD</sub>	CL=5pF, RL=1MΩ	V <sub>CC</sub> =0.8V	--	21.2	--	ns
			V <sub>CC</sub> =1.2±0.1V	2.3	5.9	--	ns
			V <sub>CC</sub> =1.5±0.1V	1.8	4.1	--	ns
			V <sub>CC</sub> =1.8±0.15V	1.5	3.3	--	ns
			V <sub>CC</sub> =2.5±0.2V	1.2	2.6	--	ns
			V <sub>CC</sub> =2.7±0.3V	1	2.3	--	ns
		CL=10pF, RL=1MΩ	V <sub>CC</sub> =0.8V	--	24.7	--	ns
			V <sub>CC</sub> =1.2±0.1V	2.6	6.8	--	ns
			V <sub>CC</sub> =1.5±0.1V	2.2	4.8	--	ns
			V <sub>CC</sub> =1.8±0.15V	1.8	3.9	--	ns
			V <sub>CC</sub> =2.5±0.2V	1.5	3.1	--	ns
			V <sub>CC</sub> =2.7±0.3V	1.3	2.9	--	ns
		CL=15pF, RL=1MΩ	V <sub>CC</sub> =0.8V	--	28.2	--	ns
			V <sub>CC</sub> =1.2±0.1V	3.0	7.6	--	ns
			V <sub>CC</sub> =1.5±0.1V	2.4	5.3	--	ns
			V <sub>CC</sub> =1.8±0.15V	2.1	4.4	--	ns
			V <sub>CC</sub> =2.5±0.2V	1.8	3.6	--	ns
			V <sub>CC</sub> =2.7±0.3V	1.6	3.3	--	ns
		CL=30pF, RL=1MΩ	V <sub>CC</sub> =0.8V	--	38.5	--	ns
			V <sub>CC</sub> =1.2±0.1V	3.9	9.9	--	ns
			V <sub>CC</sub> =1.5±0.1V	3.2	6.9	--	ns
			V <sub>CC</sub> =1.8±0.15V	2.8	5.7	--	ns
			V <sub>CC</sub> =2.5±0.2V	2.4	4.7	--	ns
			V <sub>CC</sub> =2.7±0.3V	2.2	4.4	--	ns

**TEST CIRCUIT AND WAVEFORMS**

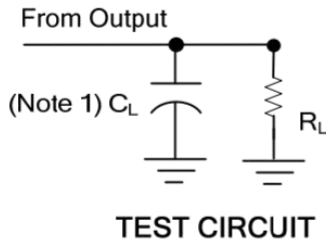

$V_{CC}$	$V_{IN}$	$t_R / t_F$	$V_M$	$C_L$	$R_L$
0.8V	$V_{CC}$	$\leq 3ns$	$V_{CC}/2$	5, 10, 15, 30pF	1M $\Omega$
1.2V $\pm$ 0.1V	$V_{CC}$	$\leq 3ns$	$V_{CC}/2$	5, 10, 15, 30pF	1M $\Omega$
1.5V $\pm$ 0.1V	$V_{CC}$	$\leq 3ns$	$V_{CC}/2$	5, 10, 15, 30pF	1M $\Omega$
1.8V $\pm$ 0.15V	$V_{CC}$	$\leq 3ns$	$V_{CC}/2$	5, 10, 15, 30pF	1M $\Omega$
2.5V $\pm$ 0.2V	$V_{CC}$	$\leq 3ns$	$V_{CC}/2$	5, 10, 15, 30pF	1M $\Omega$

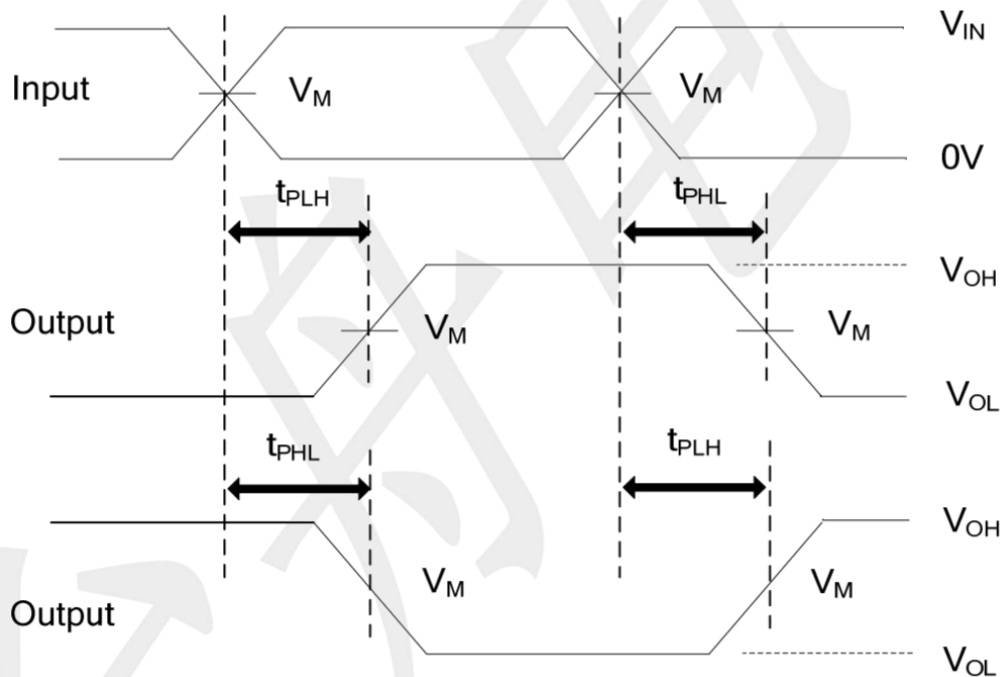

Notes:

1.  $C_L$  includes probe and jig capacitance.
2. All input pulses are supplied by generators having the following characteristics: PRR  $\leq$  10MHz,  $Z_O = 50\Omega$ .

**Package information (Unit: mm)**

SOT-353

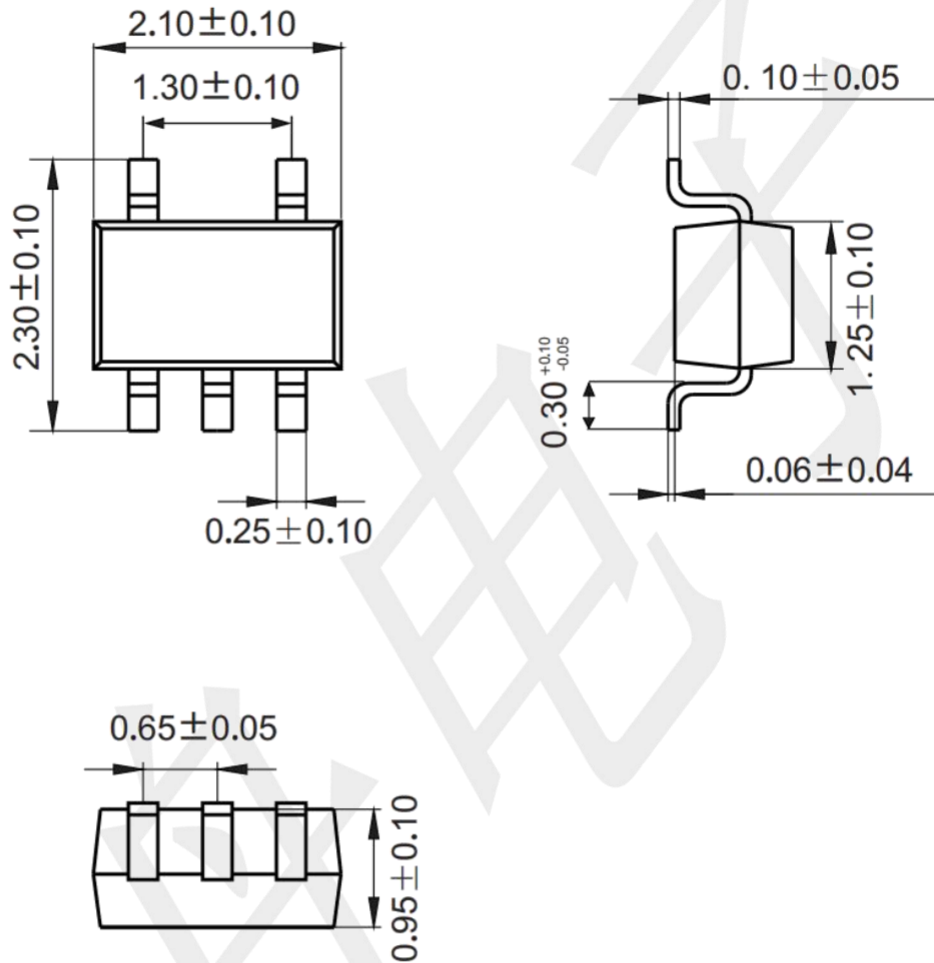

**Mounting Pad Layout (unit: mm)**

