

Features

- Low operating voltage: 8V
- Ultra low capacitance: 120pF
- Ultra low leakage: nA level
- Low clamping voltage
- -IEC 61000-4-2 (ESD) immunity test
 - Air discharge: $\pm 30\text{kV}$
 - Contact discharge: $\pm 30\text{kV}$
- -IEC61000-4-4 (EFT) 40A (5/50ns)
- 2-pin leadless package
- These are Pb-Free Devices
- Response Time is Typically $< 1\text{ ns}$

Mechanical Characteristics

- Package: SOD323(0805)
- Lead Finish: Matte Tin
- Case Material: "Green" Molding Compound
- Terminal Connections: See Diagram Below
- -IEC 61000-4-2 (ESD) immunity test

Applications

- Cellular Handsets and Accessories
- Personal Digital Assistants
- Notebooks and Handhelds
- Portable Instrumentation
- Peripherals

Dimensions and Pin Configuration

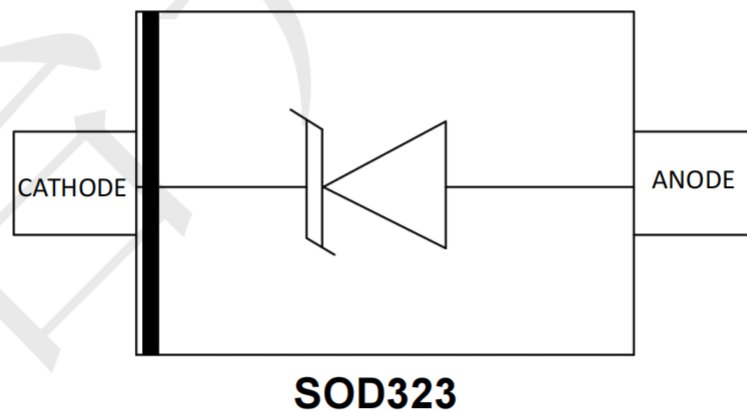

Absolute Maximum Ratings (Tamb=25°C unless otherwise specified)

Parameter	Symbol	Value	Unit
Peak Pulse Power (8/20µs)	Ppk	400	W
Peak Pulse Current (8/20µs)	Ipp	20	A
ESD per IEC 61000-4-2 (Air) ESD per IEC 61000-4-2 (Contact)	VESD	±30 ±30	KV
Operating Temperature Range	TJ	-55 to +125	°C
Storage Temperature Range	Tstg	-55 to +150	°C

Electrical Characteristics (TA=25°C unless otherwise specified)

Parameter	Symbol	Min	Typ	Max	Unit	Test Condition
Reverse Working Voltage	VRWM	--	--	8	V	
Breakdown Voltage	VBR	9	--	12	V	IT= 1mA
Reverse Leakage Current	IR	--	--	0.1	uA	VRWM=8V
Forward voltage	VF	--	0.8	1.2	V	IF=1mA
Clamping Voltage	VC	--	15	--	V	Ipp=1A(8x 20us pulse)
Clamping Voltage	VC	--	--	20	V	Ipp=20A(8x 20us pulse)
Junction Capacitance	CJ	--	--	120	pF	VR = 0V, f = 1MHz

Symbol	Parameter
I _{PP}	Maximum Reverse Peak Pulse Current
V _C	Clamping Voltage @ I _{PP}
V _{RWM}	Working Peak Reverse Voltage
I _R	Maximum Reverse Leakage Current @ V _{RWM}
V _{BR}	Breakdown Voltage @ I _T
I _T	Test Current
I _F	Forward Current
V _F	Forward Voltage @ I _F
P _{pk}	Peak Power Dissipation
C	Capacitance @ V _R = 0 and f = 1.0 MHz

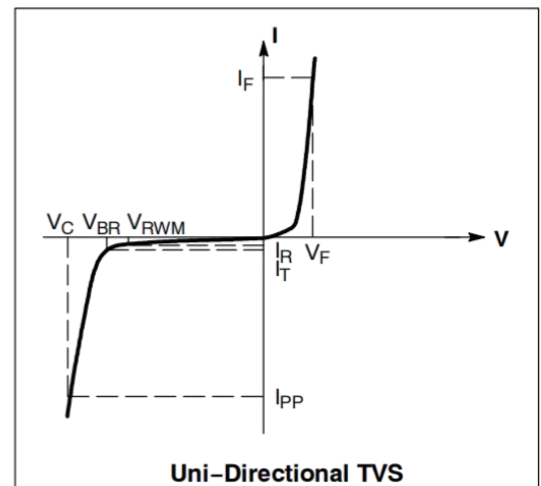

Characteristic Curves

Fig1. 8/20 μ s Pulse Waveform

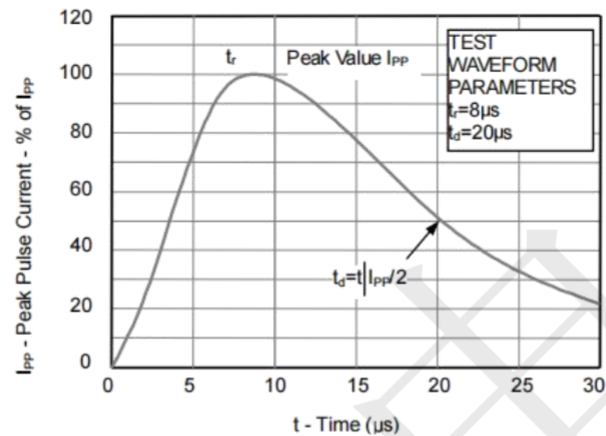

Fig2. ESD Pulse Waveform (according to IEC 61000-4-2)

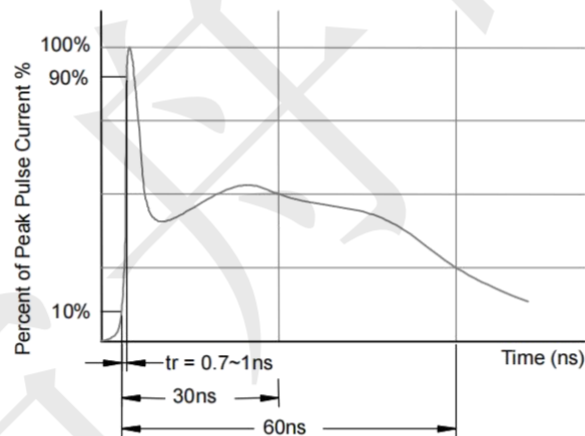
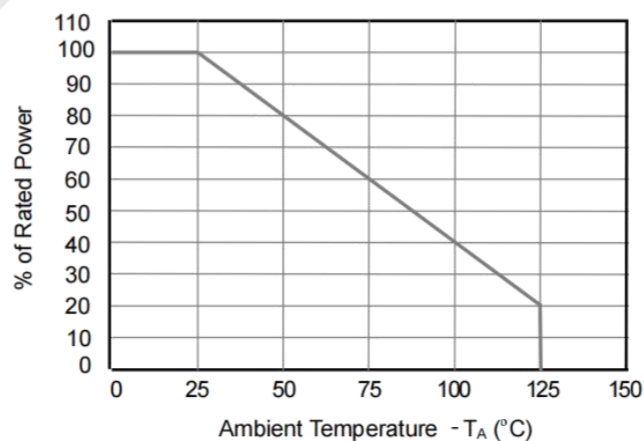
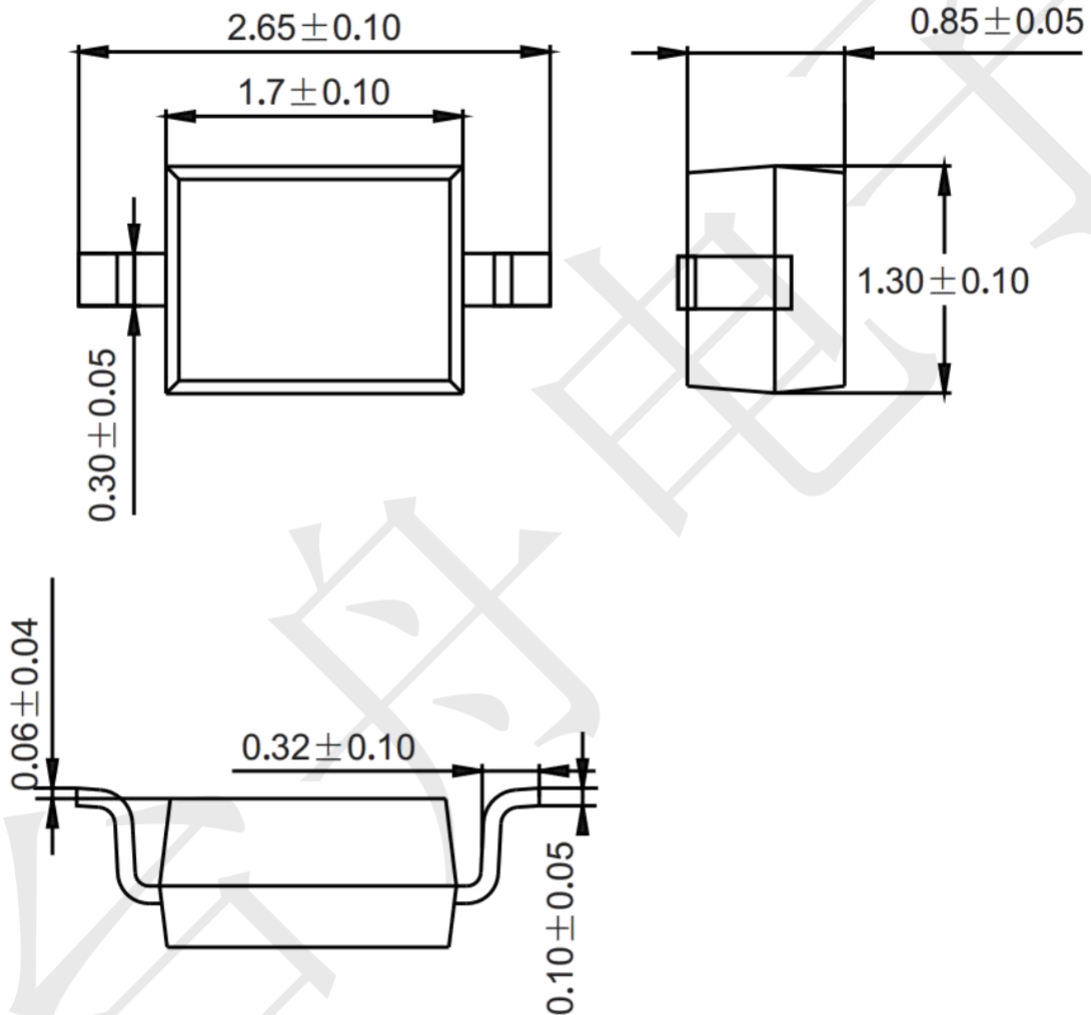

Fig3. Power Derating Curve



Package Outline Dimensions (unit: mm)

SOD323 (0805)



Mounting Pad Layout (unit: mm)

