

BNPESD5V0X1BCAL

ESD Protection Diode

Features

- 125Watts peak pulse power ($t_p = 8/20\mu s$)
- Bidirectional configurations
- Solid-state silicon-avalanche technology
- Low clamping Voltage
- Low leakage current
- Low capacitance ($C_j=0.3pF$ typ.)
- Protection one data/power line
- IEC 61000-4-2 $\pm 20kV$ contact ; $\pm 25kV$ air
- IEC 61000-4-4 (EFT) 40A (5/50ns)
- IEC 61000-4-5 (Lightning) 5A (8/20 μs)

Package

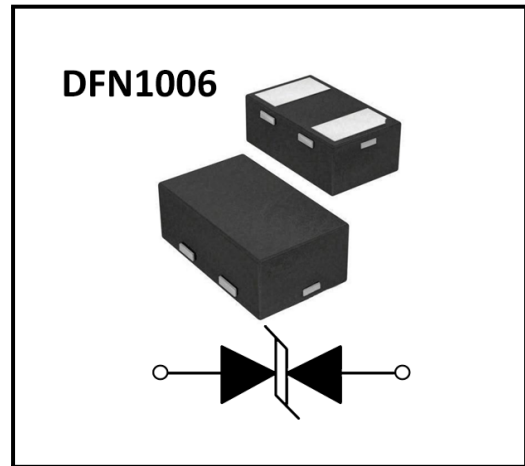

Applications

- Cell Phone Handsets and Accessories
- Microprocessor based equipment
- Personal Digital Assistants (PDA's)
- Notebooks, Desktops, and Servers
- Portable Instrumentation

Mechanical Characteristics

- DFN1006 package
- Molding compound flammability rating: UL 94V-0
- Packaging: Tape and Reel
- RoHS/WEEE Compliant

Marking

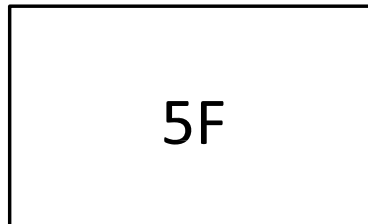

Ordering information

Order code	Package	Base qty	Delivery mode
BNPESD5V0X1BCAL	DFN1006	10k	Tape and reel

**BORN SEMICONDUCTOR, INC. ALL
RIGHT RESERVED**

Specifications are subject to change without notice.

Please refer to <http://www.born-tw.com> for current information.

Revision: 2022-Jan-1-A



BNPESD5V0X1BCAL

ESD Protection Diode

Electrical Parameters ($T_A = 25^\circ\text{C}$ unless otherwise noted)

Symbol	Parameter
I_{PP}	Maximum Reverse Peak Pulse Current
V_C	Clamping Voltage @ I_{PP}
V_{RWM}	Peak Reverse Working Voltage
I_R	Reverse Leakage Current @ V_{RWM}
V_{BR}	Breakdown Voltage @ I_T
I_T	Test Current

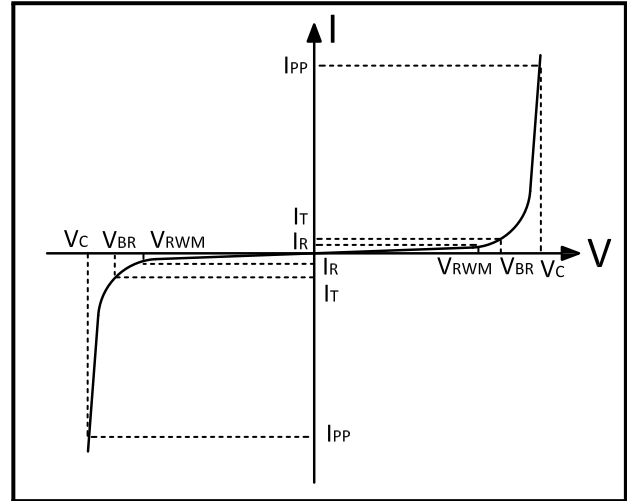

Note: 8/20us pulse Waveform.

Absolute Maximum Rating

Rating	Symler	Value	Units
Peak Pulse Power ($t_p = 8/20\mu\text{s}$)	P_{PP}	125	Watts
Peak Pulse Current ($t_p = 8/20\mu\text{s}$)	I_{PP}	5.0	A
ESD per IEC 61000-4-2 (Air)	V_{ESD}	25	KV
ESD per IEC 61000-4-2 (Contact)		20	
Lead Soldering Temperature	T_L	260(10seconds)	$^\circ\text{C}$
Junction Temperature	T_J	-55 to + 150	$^\circ\text{C}$
Storage Temperature	T_{stg}	-55 to + 150	$^\circ\text{C}$

Electrical Characteristics

Parameter	Symler	Conditions	Min	Typical	Max	Units
Reverse Stand-Off Voltage	V_{RWM}	–	–	–	5.0	V
Reverse Breakdown Voltage	V_{BR}	$I_T = 1\text{mA}$	6.0	7.8	9.5	V
Reverse Leakage Current	I_R	$V_{RWM} = 5.0\text{V}, T = 25^\circ\text{C}$	–	0.1	0.5	μA
Peak Pulse Current	I_{PP}	$t_p = 8/20\mu\text{s}$	–	–	5.0	A
Clamping Voltage	V_C	$I_{PP} = 5\text{A}, t_p = 8/20\mu\text{s}$	–	20	–	V
Junction Capacitance	C_j	$V_R = 0\text{V}, f = 1\text{MHz}$	–	0.3	0.5	pF





BNPESD5V0X1BCAL

ESD Protection Diode

Typical Characteristics

Figure 1: Peak Pulse Power vs. Pulse Time

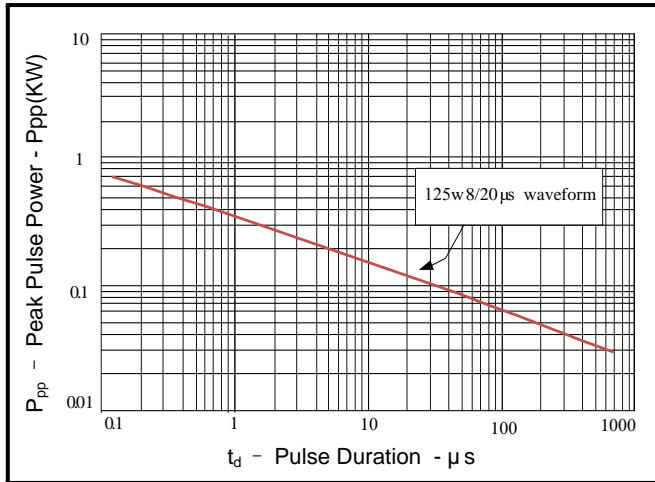

Figure 2: Power Derating Curve

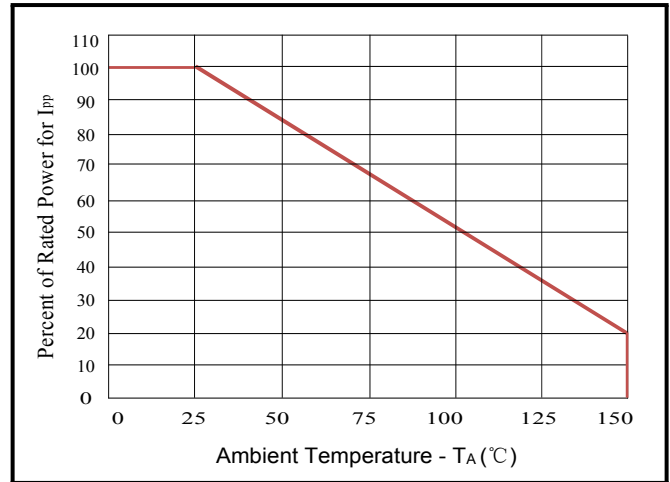

Figure 3: Pulse Waveform

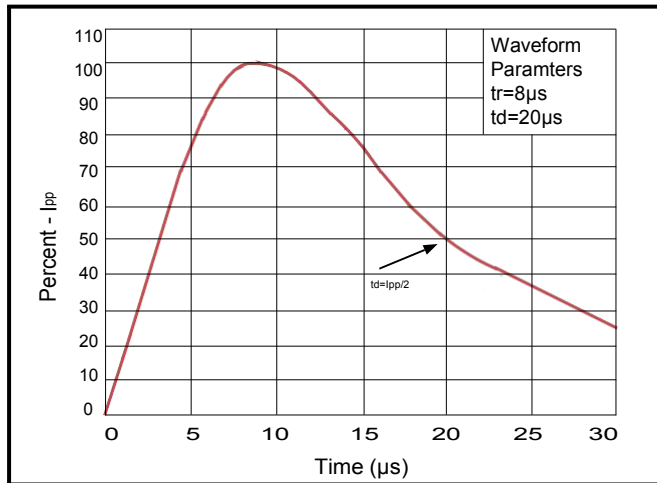
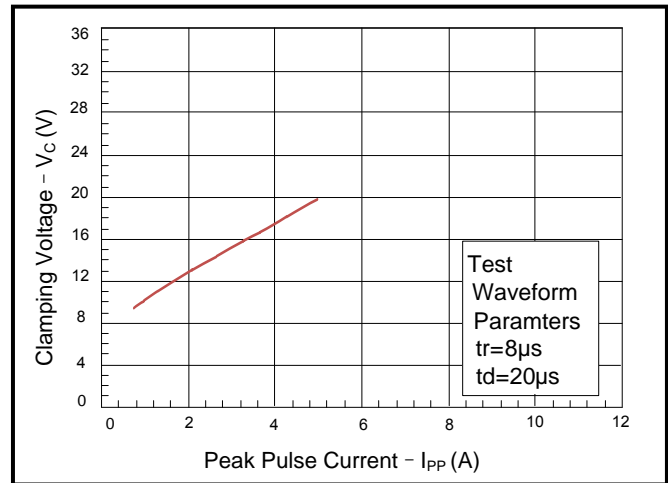

Figure 4: Clamping Voltage vs. Ipp



BNPESD5V0X1BCAL

ESD Protection Diode

Outline Drawing – DFN1006

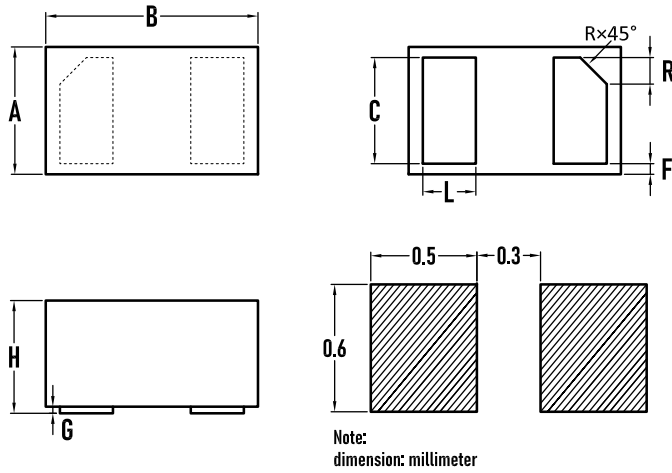

SYMBOL	MILLIMETER		
	MIN.	Typ.	MAX.
A	0.55	0.60	0.65
B	0.95	1.00	1.05
C	0.45	0.50	0.55
L	0.20	0.25	0.30
F	0.05REF		
G	0.00	0.02	0.05
H	0.45	0.50	0.55
R	0.07	0.12	0.17

Packaging Tape - DFN1006

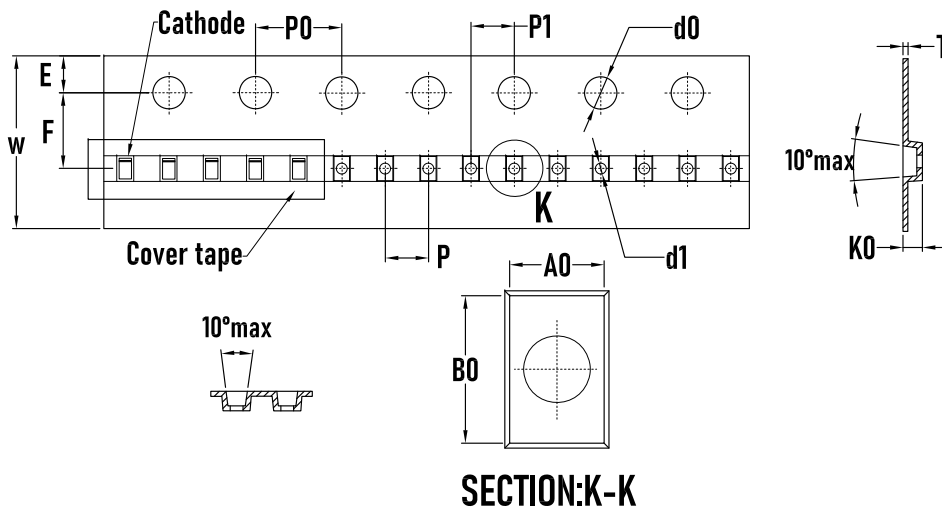

SYMBOL	MILLIMETER
A0	0.71±0.05
B0	1.11±0.05
d0	1.5 ^{+0.1} ₋₀
d1	0.50±0.05
E	1.75±0.10
F	3.50±0.05
K0	0.56±0.05
P	2.00±0.05
P0	4.00±0.10
P1	2.00±0.05
W	8.00 ^{+0.03} _{-0.01}
T	0.2±0.015

Packaging Reel

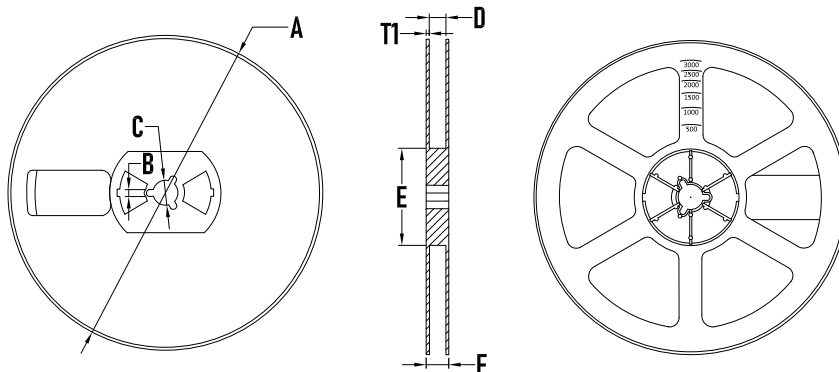

SYMBOL	MILLIMETER
A	178±1
B	3.5±0.2
C	14.3±0.2
D	9.8 ⁺² ₋₁
E	54.5±0.5
F	12.4±0.2
T1	1.0±0.2
Quantity	10000PCS

**BORN SEMICONDUCTOR, INC. ALL
RIGHT RESERVED**

Specifications are subject to change without notice.

Please refer to <http://www.born-tw.com> for current information.

Revision: 2022-Jan-1-A

