

### Features

- Wide supply voltage range from 2.0 V to 6.0V
- CMOS low power dissipation
- Overvoltage tolerant inputs to 6.0 V
- Latch-up performance exceeds 250 mA
- Direct interface with TTL levels
- ESD protection:  
HBM ANSI/ESDA/JEDEC JS-00  
Class 3A exceeds 6000 V  
CDM ANSI/ESDA/JEDEC JS-002  
Class C3 exceeds 2000 V
- I<sub>OFF</sub> circuitry provides partial Power-down mode operation
- Complies with JEDEC standard:  
JESD8-5 (2.3 V to 2.7 V)  
JESD8C (2.7 V to 3.6 V)  
JESD36 (4.5 V to 5.5 V)
- Packaging: TSSOP-14

### General Description

The is a quad buffer/line driver with 3-state outputs controlled by the output enable inputs (nOE). A HIGH on nOE causes the outputs to assume a high impedance OFF-state. Inputs can be driven from either 3.3 V or 5 V devices. This feature allows the use of these devices as translators in mixed 3.3 V and 5 V environments.

Schmitt-trigger action at all inputs makes the circuit tolerant of slower input rise and fall times.

### PIN CONFIGURATIONS (Top view)

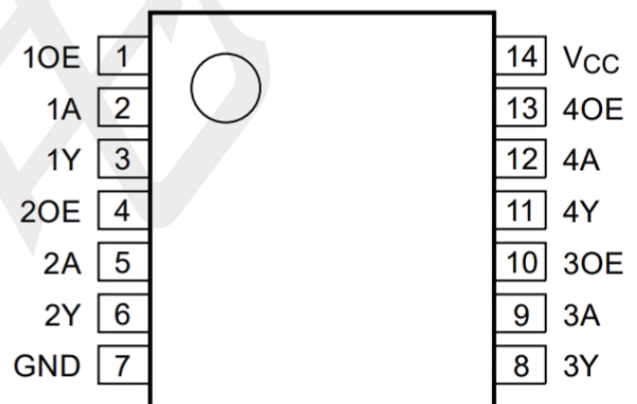

TSSOP-14

### PIN DESCRIPTION

PIN NO.	PIN NAME	DESCRIPTION	PIN NO.	PIN NAME	DESCRIPTION
1	1OE	Data enable input(active HIGH)	8	3Y	Data output
2	1A	Data input	9	3A	Data input
3	2Y	Data output	10	3OE	Data enable input(active HIGH)
4	2OE	Data enable input(active HIGH)	11	4Y	Data output
5	2A	Data input	12	4A	Data input
6	2Y	Data output	13	4OE	Data enable input(active HIGH)
7	GND	ground (0 V)	14	V <sub>CC</sub>	supply voltage

### Functional diagram

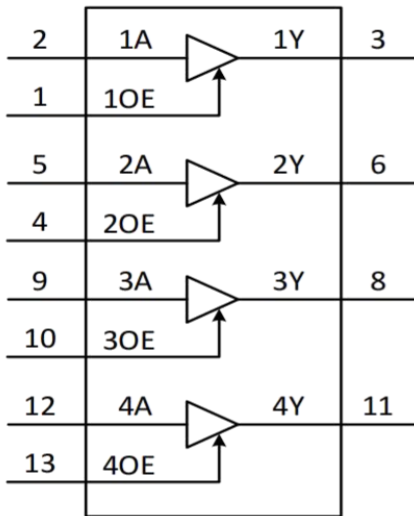

Fig. 1. Logic symbol

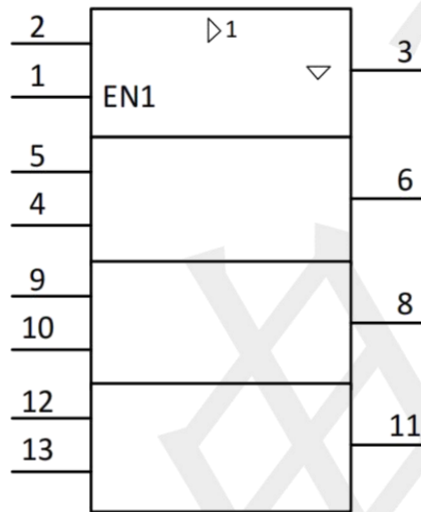

Fig. 2. IEC logic symbol

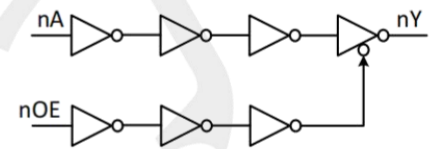

Fig. 3. Logic diagram(one gate)

### Functional Description

#### Function table

Input		Output
nOE	nA	nY
H	L	L
H	H	H
L	X	Z

H = HIGH voltage level; L = LOW voltage level; X = don't care; Z = high-impedance OFF-state.

### ABSOLUTE MAXIMUM RATINGS

In accordance with the Absolute Maximum Rating System. Voltages are referenced to GND.

Symbol	Parameter	Conditions	Min	Max	Unit
V <sub>CC</sub>	supply voltage		-0.5	7.0	V
I <sub>IK</sub>	input clamping current	V <sub>I</sub> < 0 V	-50	--	mA
V <sub>I</sub>	input voltage	(1)	-0.5	7.0	V
I <sub>OK</sub>	output clamping current	V <sub>O</sub> > V <sub>CC</sub> or V <sub>O</sub> < 0 V	--	±50	mA
V <sub>O</sub>	output voltage	Active mode (1)	0	V <sub>CC</sub> + 0.5	V
		Power-down mode; V <sub>CC</sub> = 0 V (1)	0	7.0	V
I <sub>O</sub>	output current	V <sub>O</sub> = 0 V to V <sub>CC</sub>	--	±50	mA
I <sub>CC</sub>	supply current		--	100	mA
I <sub>GND</sub>	ground current		-100	--	mA
P <sub>tot</sub>	total power dissipation	T <sub>amb</sub> = -40 °C to + 125 °C	--	500	mW
T <sub>stg</sub>	storage temperature		-65	150	°C

**Note:**1. The input and output voltage ratings may be exceeded if the input and output current ratings are observed.

### Recommended operating conditions

Symbol	Parameter	Conditions	Min	Max	Unit
V <sub>CC</sub>	supply voltage		2.0	6.0	V
		functional	1.5	--	V
V <sub>I</sub>	input voltage		0	6.0	V
V <sub>O</sub>	output voltage	Active mode	0	V <sub>CC</sub>	V
		Power-down mode; V <sub>CC</sub> = 0 V	0	6.0	V
T <sub>amb</sub>	ambient temperature		-40	125	°C
Δt/ΔV	Input transition rise and fall rate	V <sub>CC</sub> = 2.0 V to 2.7 V	0	20	ns/V
		V <sub>CC</sub> = 2.7 V to 6.0 V	0	10	ns/V

### Static characteristics

At recommended operating conditions. Voltages are referenced to GND (ground = 0 V).

Symbol	Parameter	Conditions	-40 °C to +85 °C			-40 °C to +125 °C		Unit
			Min	Typ	Max	Min	Max	
V <sub>IH</sub>	HIGH-level input voltage	V <sub>CC</sub> = 2.0 V	0.65V <sub>CC</sub>	--	--	0.65V <sub>CC</sub>	--	V
		V <sub>CC</sub> = 2.3 V to 2.7 V	1.7	--	--	1.7	--	V
		V <sub>CC</sub> = 2.7 V to 3.6 V	2.0	--	--	2.0	--	V
		V <sub>CC</sub> = 4.5 V to 6.0 V	0.7V <sub>CC</sub>	--	--	0.7V <sub>CC</sub>	--	V
V <sub>IL</sub>	LOW-level input voltage	V <sub>CC</sub> = 2.0 V	--	--	0.35V <sub>CC</sub>	--	0.35V <sub>CC</sub>	V
		V <sub>CC</sub> = 2.3 V to 2.7 V	--	--	0.7	--	0.7	V
		V <sub>CC</sub> = 2.7 V to 3.6 V	--	--	0.8	--	0.8	V
		V <sub>CC</sub> = 4.5 V to 6.0 V	--	--	0.3V <sub>CC</sub>	--	0.3V <sub>CC</sub>	V
V <sub>OH</sub>	HIGH-level output voltage	V <sub>I</sub> = V <sub>IH</sub> or V <sub>IL</sub>						
		I <sub>O</sub> = -100μA; V <sub>CC</sub> = 2.0 V to 6.0 V	V <sub>CC</sub> - 0.1	--	--	V <sub>CC</sub> - 0.1	--	V
		I <sub>O</sub> = -4 mA; V <sub>CC</sub> = 2.0 V	1.5	--	--	1.25	--	V
		I <sub>O</sub> = -8 mA; V <sub>CC</sub> = 2.3 V	1.9	--	--	1.7	--	V
		I <sub>O</sub> = -12 mA; V <sub>CC</sub> = 2.7 V	2.2	--	--	2.05	--	V
		I <sub>O</sub> = -24 mA; V <sub>CC</sub> = 3.0 V	2.4	--	--	2.25	--	V
V <sub>OL</sub>	LOW-level output voltage	V <sub>I</sub> = V <sub>IH</sub> or V <sub>IL</sub>						
		I <sub>O</sub> = 100μA; V <sub>CC</sub> = 2.0 V to 6.0 V	--	--	0.10	--	0.10	V
		I <sub>O</sub> = 4 mA; V <sub>CC</sub> = 2.0 V	--	--	0.45	--	0.65	V
		I <sub>O</sub> = 8 mA; V <sub>CC</sub> = 2.3 V	--	--	0.30	--	0.45	V
		I <sub>O</sub> = 12 mA; V <sub>CC</sub> = 2.7 V	--	--	0.40	--	0.60	V
		I <sub>O</sub> = 24 mA; V <sub>CC</sub> = 3.0 V	--	--	0.55	--	0.80	V
		I <sub>O</sub> = 32 mA; V <sub>CC</sub> = 4.5 V	--	--	0.55	--	0.80	V
I <sub>I</sub>	Input leakage current	V <sub>I</sub> = 6.0 V or GND ; V <sub>CC</sub> = 0 V to 6.0 V	--	±0.1	±5	--	±20	μA

### Static characteristics

At recommended operating conditions. Voltages are referenced to GND (ground = 0 V).

Symbol	Parameter	Conditions	-40 °C to +85 °C			-40 °C to +125 °C		Unit
			Min	Typ	Max	Min	Max	
$I_{OZ}$	OFF-state output current	$V_I = V_{IH}$ or $V_{IL}$ ; $V_{CC} = 6.0V$ ; $V_O = 6.0V$ or GND	--	$\pm 0.1$	$\pm 5$	--	$\pm 20$	$\mu A$
$I_{OFF}$	power-off leakage current	$V_{CC} = 0V$ ; $V_I$ or $V_O = 6.0 V$	--	$\pm 0.1$	$\pm 10$	--	$\pm 20$	$\mu A$
$I_{CC}$	supply current	$V_I = 6.0V$ or GND ; $I_O = 0A$ ; $V_{CC} = 2.0V$ to $6.0V$	--	0.01	10	--	40	$\mu A$
$\Delta I_{CC}$	additional supply current	per input pin ; $V_{CC} = 2.3V$ to $6.0V$ ; $V_I = V_{CC} - 0.6V$ ; $I_O = 0A$	--	0.2	500	--	5000	$\mu A$
$C_i$	input capacitance	$V_{CC} = 3.3V$ ; $V_I = GND$ to $V_{CC}$	--	4	--	--	--	pF

Note: All typical values are measured at  $V_{CC} = 3.3V$  and  $T_{amb} = 25\text{ }^\circ C$ .

### Dynamic Characteristics

Voltages are referenced to GND (ground = 0 V); for test circuit see

Symbol	Parameter	Conditions	-40 °C to +85 °C			-40 °C to +125 °C		Unit
			Min	Typ	Max	Min	Max	
$t_{pd}$	propagation delay	nA to nY;						
		$V_{CC} = 2.0 V$	3.0	7.9	16.2	3.0	16.5	ns
		$V_{CC} = 2.3 V$ to $2.7 V$	2.2	4.4	8.0	2.2	8.6	ns
		$V_{CC} = 3.0 V$ to $3.6 V$	1.5	3.4	5.8	1.5	6.0	ns
		$V_{CC} = 4.5 V$ to $6.0 V$	1.1	2.6	4.0	1.1	4.5	ns

### Dynamic Characteristics

Voltages are referenced to GND (ground = 0 V); for test circuit see

Symbol	Parameter	Conditions	-40 °C to +85 °C			-40 °C to +125 °C		Unit
			Min	Typ	Max	Min	Max	
$t_{en}$	enable time	nOE to nY						
		$V_{CC} = 2.0V$	3.0	8.0	15.5	3.0	15.7	ns
		$V_{CC} = 2.3 V$ to $2.7 V$	2.2	4.8	8.0	2.2	8.2	ns
		$V_{CC} = 3.0 V$ to $3.6 V$	1.5	3.4	5.8	1.5	6.0	ns
		$V_{CC} = 4.5 V$ to $6.0 V$	0.6	2.8	4.0	0.6	4.5	ns
$t_{dis}$	disable time	nOE to nY						
		$V_{CC} = 2.0 V$	2.0	7.2	15.5	2.0	15.7	ns
		$V_{CC} = 2.3 V$ to $2.7 V$	1.6	5.7	8.6	1.6	8.8	ns
		$V_{CC} = 3.0 V$ to $3.6 V$	1.3	4.5	6.5	1.3	7.0	ns
		$V_{CC} = 4.5 V$ to $6.0 V$	0.4	2.7	4.5	0.4	5.0	ns
$C_{PD}$	power dissipation capacitance	per buffer ; $V_I = GND$ to $V_{CC}$						
		$V_{CC} = 2.0 V$	--	12	--	--	--	pF
		$V_{CC} = 2.3 V$ to $2.7 V$	--	13	--	--	--	pF
		$V_{CC} = 3.0 V$ to $3.6 V$	--	14	--	--	--	pF
		$V_{CC} = 4.5 V$ to $6.0 V$	--	16	--	--	--	pF
$t_{sk(o)}$	output skew time	$V_{CC} = 3.0 V$ to $3.6 V$	--	--	1.0	--	1.5	ns

**Note:**

Typical values are measured at  $T_{amb} = 25 °C$  and  $V_{CC} = 2.0 V, 2.5 V, 3.3 V$  and  $6.0 V$  respectively.

$t_{pd}$  is the same as  $t_{PLH}$  and  $t_{PHL}$ .

Skew between any two outputs of the same package switching in the same direction. This parameter is guaranteed by design.

$C_{PD}$  is used to determine the dynamic power dissipation ( $P_D$  in  $\mu W$ ).

$$P_D = C_{PD} \times V_{CC}^2 \times f_i \times N + \sum(C_L \times V_{CC}^2 \times f_o) \text{ where:}$$

$f_i$  = input frequency in MHz;

$f_o$  = output frequency in MHz;

$C_L$  = output load capacitance in

pF;  $V_{CC}$  = supply voltage in V;

$N$  = number of inputs switching;

$\sum(C_L \times V_{CC}^2 \times f_o)$  = sum of outputs.

### Waveforms and test circuit

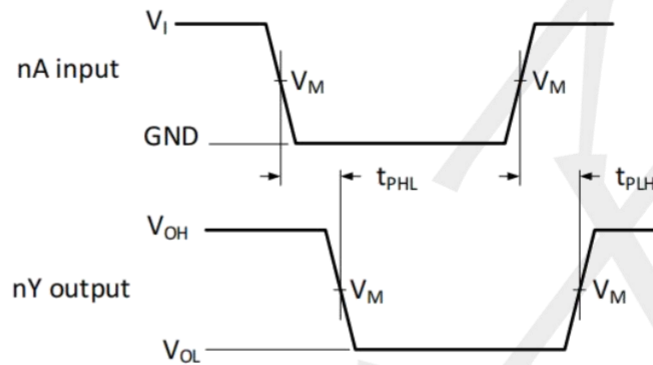

Measurement points are given in Table 8.

$V_{OL}$  and  $V_{OH}$  are typical output voltage levels that occur with the output load.

Fig. 5. The input nA to output nY propagation delays

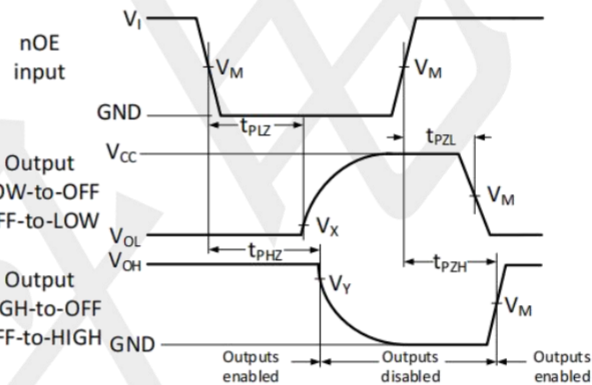

Measurement points are given in Table 8.

$V_{OL}$  and  $V_{OH}$  are typical output voltage levels that occur with the output load.

Fig. 6. 3-state enable and disable times

### Measurement points

Supply voltage	Input	Output		
$V_{CC}$	$V_M$	$V_M$	$V_X$	$V_Y$
2.0 V	$0.5V_{CC}$	$0.5V_{CC}$	$V_{OL} + 0.15V$	$V_{OH} - 0.15V$
2.3 V to 2.7 V	$0.5V_{CC}$	$0.5V_{CC}$	$V_{OL} + 0.15V$	$V_{OH} - 0.15V$
3.0 V to 3.6 V	1.5 V	1.5 V	$V_{OL} + 0.3V$	$V_{OH} - 0.3V$
4.5 V to 6.0 V	$0.5V_{CC}$	$0.5V_{CC}$	$V_{OL} + 0.3V$	$V_{OH} - 0.3V$

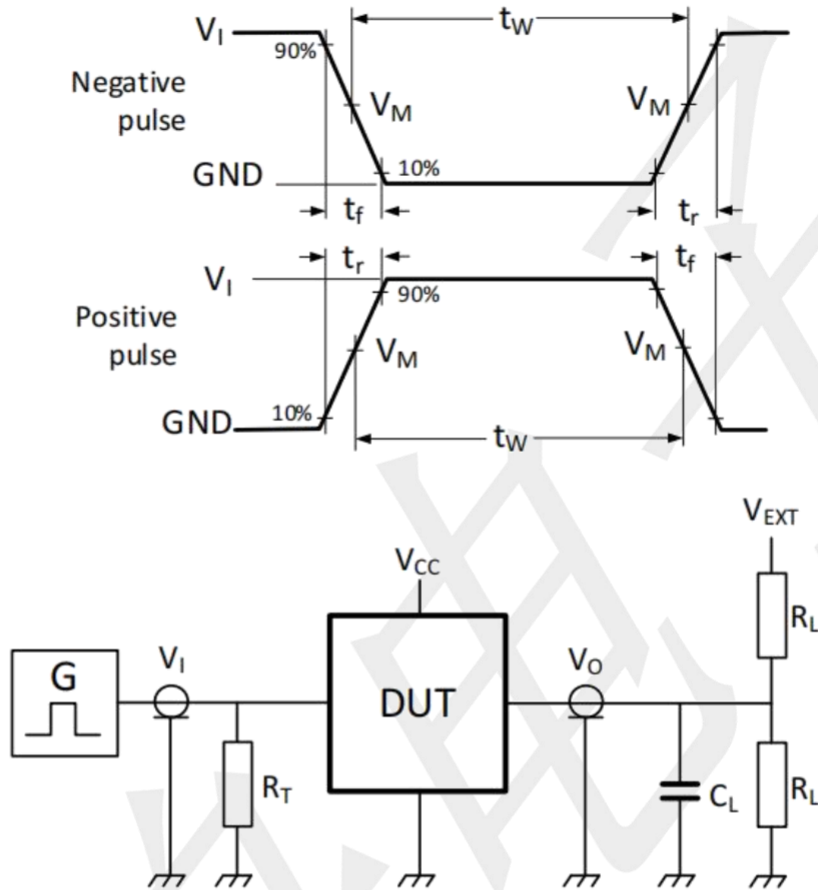

Test data is given in Table 9.

Definitions for test circuit:

$R_L$  = Load resistance.

$C_L$  = Load capacitance including jig and probe capacitance.

$R_T$  = Termination resistance should be equal to the output impedance  $Z_o$  of the pulse generator.

$V_{EXT}$  = External voltage for measuring switching times.

Fig. 7. Test circuit for measuring switching times

### Test data

Supply voltage	Input		Load		$V_{EXT}$		
	$V_I$	$t_r = t_f$	$C_L$	$R_L$	$t_{PLH}, t_{PHL}$	$t_{PZH}, t_{PHZ}$	$t_{PZL}, t_{PLZ}$
2.0 V	$V_{CC}$	$\leq 2.0$ ns	15 pF	500 $\Omega$	open	GND	$2 \times V_{CC}$
2.3 V to 2.7 V	$V_{CC}$	$\leq 2.0$ ns	15 pF	500 $\Omega$	open	GND	$2 \times V_{CC}$
3.0 V to 3.6 V	3 V	$\leq 2.0$ ns	15 pF	500 $\Omega$	open	GND	6V
4.5 V to 6.0 V	$V_{CC}$	$\leq 2.0$ ns	15 pF	500 $\Omega$	open	GND	$2 \times V_{CC}$

### Package information TSSOP-14

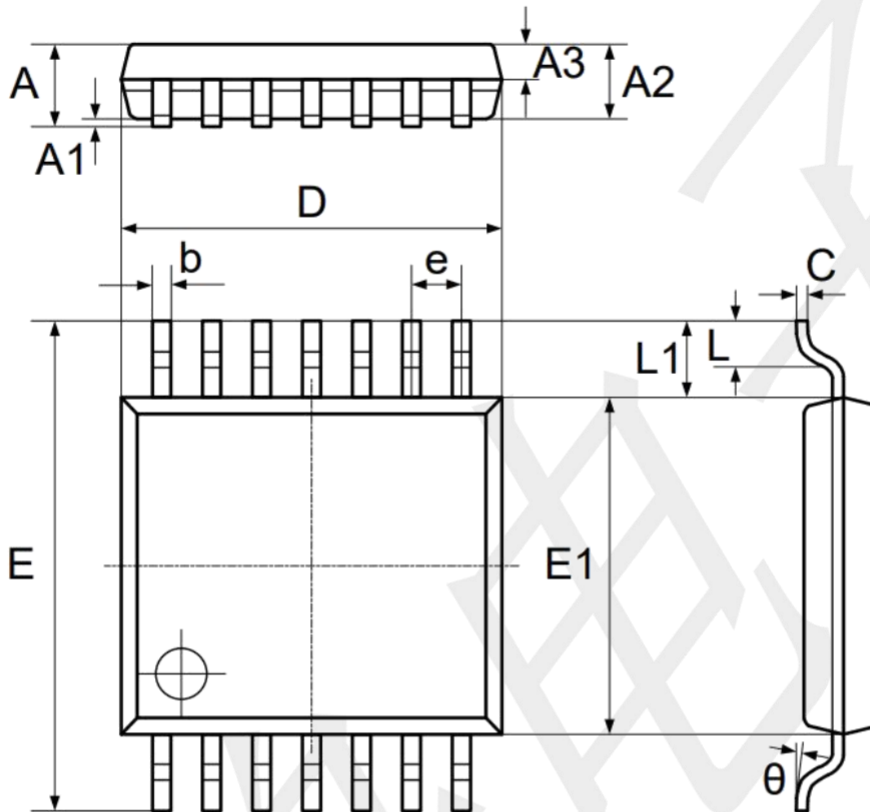

Symbol	Dimensions In Millimeters		Dimensions In Inches	
	Min	Max	Min	Max
A	-	1.200	-	0.047
A1	0.050	0.150	0.002	0.006
A2	0.900	1.050	0.035	0.041
A3	0.390	0.490	0.015	0.019
b	0.200	0.290	0.008	0.011
C	0.130	0.180	0.005	0.007
D	4.860	5.060	0.191	0.199
E	6.200	6.600	0.244	0.260
E1	4.300	4.500	0.169	0.177
e	0.650 TYP.		0.026 TYP.	
L1	1.000 REF.		0.039 REF.	
L	0.450	0.750	0.018	0.030
theta	0°	8°	0°	8°