

# BNESD9M5.0ST5G

ESD Protection Diode

## Features

- 105Watts peak pulse power ( $t_p = 8/20\mu s$ )
- Unidirectional configurations
- Solid-state silicon-avalanche technology
- Low clamping Voltage
- Low leakage current
- Low capacitance ( $C_j = 1.4pF$  typ.)
- Protection one data/power line
- IEC 61000-4-2  $\pm 30kV$  contact ;  $\pm 30kV$  air
- IEC 61000-4-4 (EFT) 40A (5/50ns)
- IEC 61000-4-5 (Lightning) 7A (8/20 $\mu s$ )

## Package

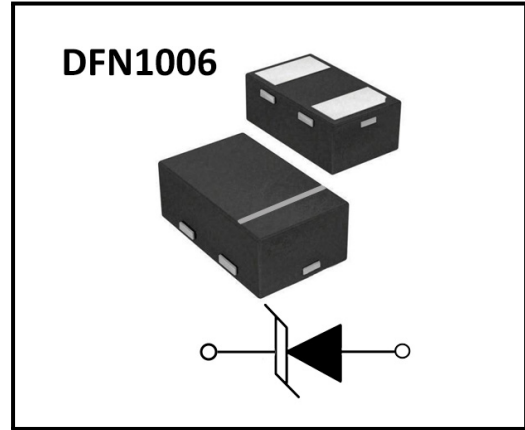

## Applications

- Cell Phone Handsets and Accessories
- Microprocessor based equipment
- Personal Digital Assistants (PDA's)
- Notebooks, Desktops, and Servers
- Portable Instrumentation

## Mechanical Characteristics

- DFN1006 package
- Molding compound flammability rating: UL 94V-0
- Packaging: Tape and Reel
- RoHS/WEEE Compliant

## Marking

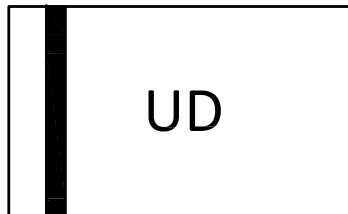

## Ordering information

Order code	Package	Base qty	Delivery mode
BNESD9M5.0ST5G	DFN1006	10k	Tape and reel



# BNESD9M5.0ST5G

ESD Protection Diode

## Electrical Parameters ( $T_A = 25^\circ\text{C}$ unless otherwise noted)

Symbol	Parameter
$I_{PP}$	Maximum Reverse Peak Pulse Current
$V_C$	Clamping Voltage @ $I_{PP}$
$V_{RWM}$	Peak Reverse Working Voltage
$I_R$	Reverse Leakage Current @ $V_{RWM}$
$V_{BR}$	Breakdown Voltage @ $I_T$
$I_T$	Test Current

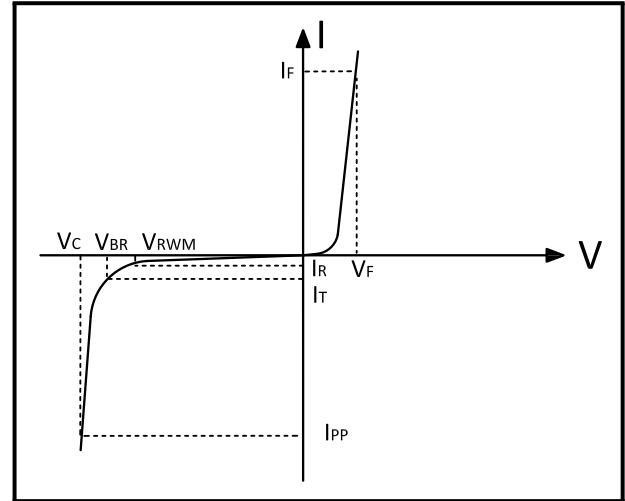

Note: 8/20us pulse Waveform.

## Absolute Maximum Rating

Rating	Symler	Value	Units
Peak Pulse Power ( $t_p = 8/20\mu\text{s}$ )	$P_{PP}$	105	Watts
Peak Pulse Current ( $t_p = 8/20\mu\text{s}$ )	$I_{PP}$	7	A
ESD per IEC 61000-4-2 (Air)	$V_{ESD}$	30	KV
ESD per IEC 61000-4-2 (Contact)		30	
Lead Soldering Temperature	$T_L$	260(10seconds)	$^\circ\text{C}$
Junction Temperature	$T_J$	-55 to + 150	$^\circ\text{C}$
Storage Temperature	$T_{stg}$	-55 to + 150	$^\circ\text{C}$

## Electrical Characteristics

Parameter	Symler	Conditions	Min	Typical	Max	Units
Reverse Stand-Off Voltage	$V_{RWM}$	-	-	-	5.0	V
Reverse Breakdown Voltage	$V_{BR}$	$I_T = 1\text{mA}$	6.0	7.2	9.5	V
Reverse Leakage Current	$I_R$	$V_{RWM} = 5\text{V}, T = 25^\circ\text{C}$	-	0.1	0.5	$\mu\text{A}$
Clamping Voltage	$V_C$	$I_{PP} = 7\text{A}, t_p = 8/20\mu\text{s}$	-	11	15	V
Junction Capacitance	$C_j$	$V_R = 0\text{V}, f = 1\text{MHZ}$	-	1.4	1.6	pF





# BNESD9M5.0ST5G

ESD Protection Diode

## Typical Characteristics

**Figure 1: Peak Pulse Power vs. Pulse Time**

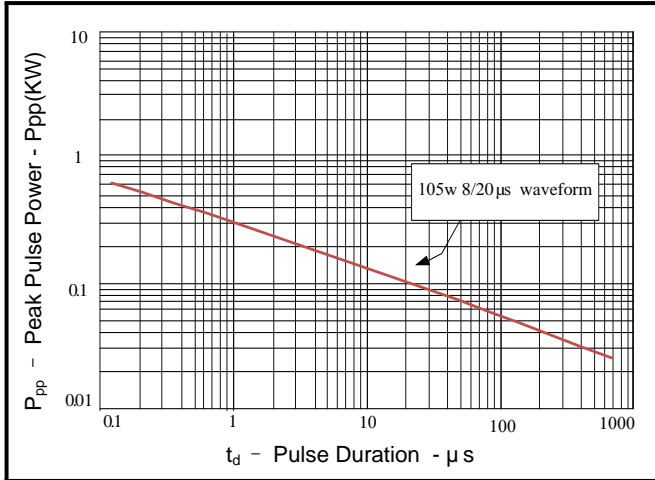

**Figure 2: Power Derating Curve**

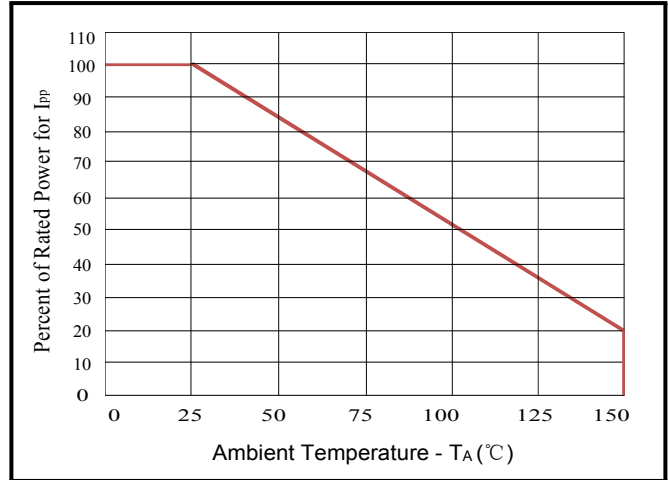

**Figure 3: Pulse Waveform**

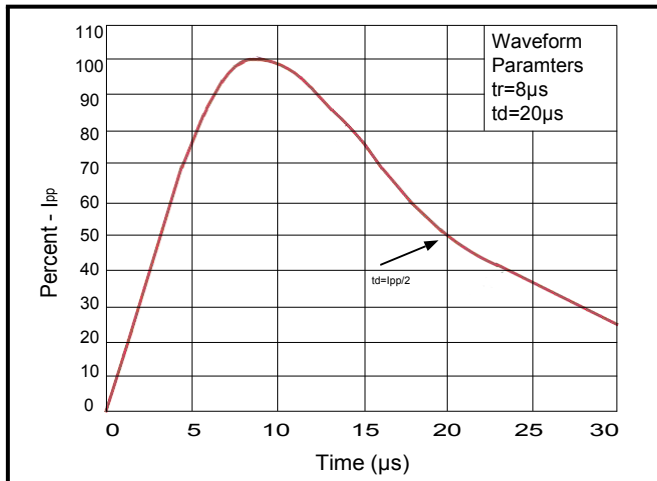

**Figure 4: Clamping Voltage vs. Ipp**

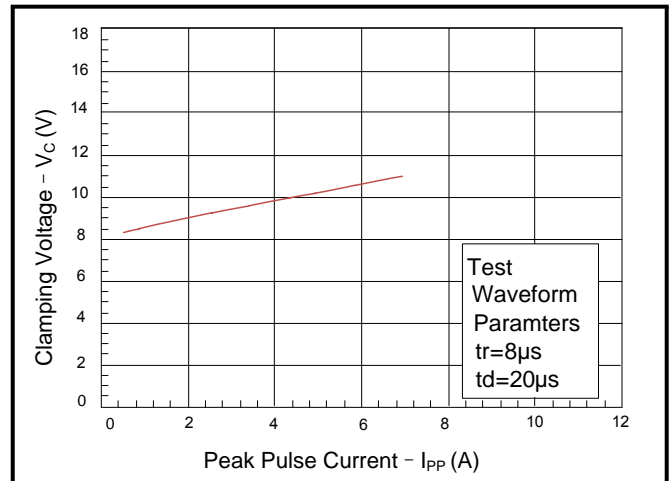

# BNESD9M5.0ST5G

ESD Protection Diode

## Outline Drawing – DFN1006

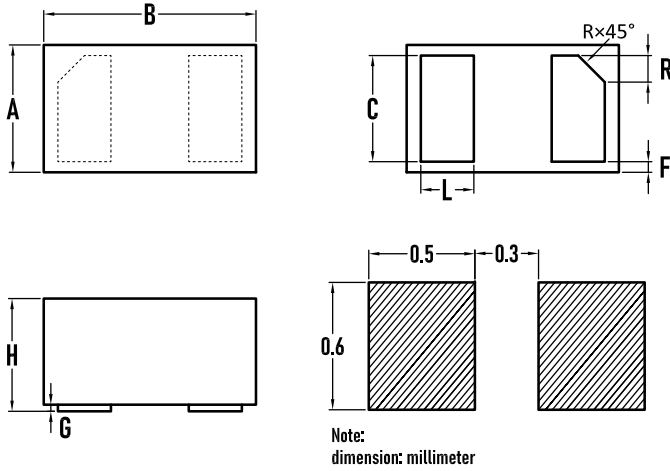

SYMBOL	MILLIMETER		
	MIN.	Typ.	MAX.
A	0.55	0.60	0.65
B	0.95	1.00	1.05
C	0.45	0.50	0.55
L	0.20	0.25	0.30
F	0.05REF		
G	0.00	0.02	0.05
H	0.45	0.50	0.55
R	0.07	0.12	0.17

## Packaging Tape - DFN1006

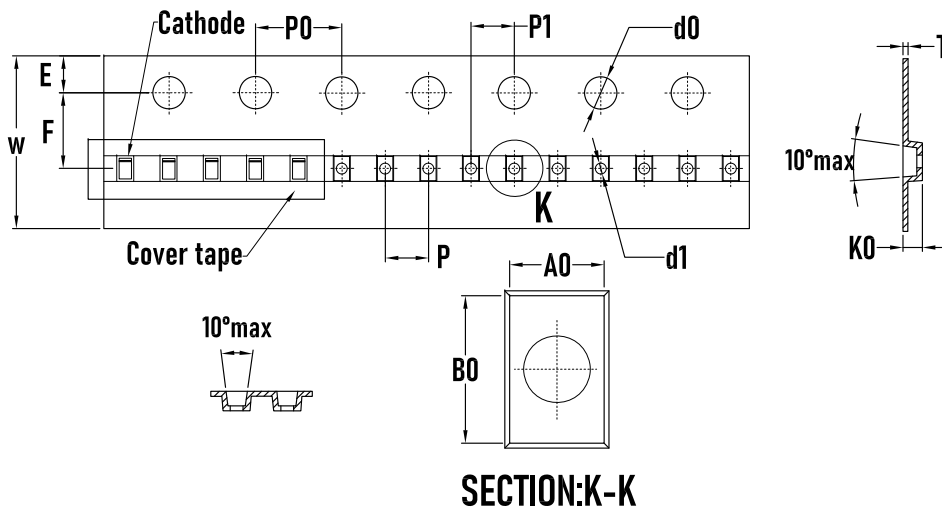

SYMBOL	MILLIMETER
A0	0.71±0.05
B0	1.11±0.05
d0	1.5 <sup>+0.1</sup> <sub>-0</sub>
d1	0.50±0.05
E	1.75±0.10
F	3.50±0.05
K0	0.56±0.05
P	2.00±0.05
P0	4.00±0.10
P1	2.00±0.05
W	8.00 <sup>+0.03</sup> <sub>-0.01</sub>
T	0.2±0.015

## Packaging Reel

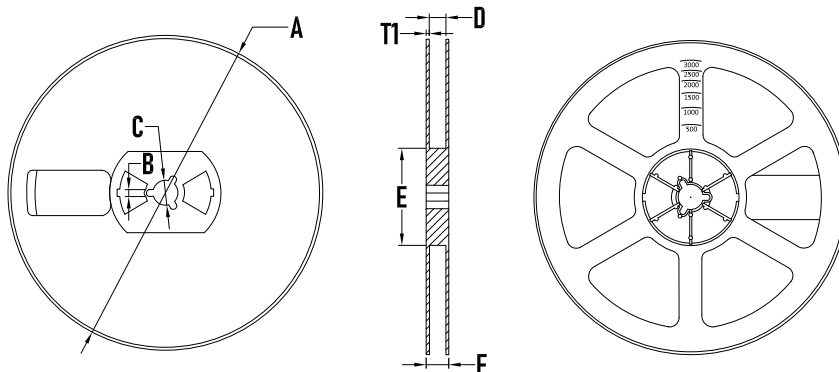

SYMBOL	MILLIMETER
A	178±1
B	3.5±0.2
C	14.3±0.2
D	9.8 <sup>+2</sup> <sub>-1</sub>
E	54.5±0.5
F	12.4±0.2
T1	1.0±0.2
Quantity	10000PCS

**BORN SEMICONDUCTOR, INC. ALL  
RIGHT RESERVED**

